

SKOOLIE

FX TYPE: Delay

Based on the EHX® Deluxe Memory Man™

Enclosure Size: 125B

"Softie" compatibility: none

© 2023 [madbeanpedals](http://madbeanpedals.com)



Overview

The Skoolie is a compact Deluxe Memory Man™ like the Tourbus project, but has been converted from positive to negative ground. The Skoolie *only requires 9v 100mA* so it will integrate easily with your existing power supplies.

There are no significant changes from the Tourbus other than those needed for the power adaptation. The Skoolie utilizes a charge pump for 15v circuit operation. A clock trimmer was also added for finer delay time calibration.

To fit this in a 125B enclosure, a couple compromises were made. The build requires 1/8W resistors and stacked PCBs. The project spans two PCBs: the Audio board and BBD board. The Audio board contains most of the audio and the LFO circuits. The BBD board comprises two MN3005 BBD and surrounding circuitry, plus most of the calibration trimmers. Stacking boards like this introduces some size limitations on components. See the Notes section for more.

If you've already built the Tourbus the Skoolie will likely be an easy build. While I don't recommend this build for the novice, I will provide extensive notes with build tips and calibration procedures at the end of this document.

Audio Controls

DELAY - Total delay time from slap-back to approximately 550ms.

FDBK - The total number of repeats from one to many to self-oscillation.

LEVEL - The input gain of the circuit. This control can create mild overdrive when turned up. It also increases the output volume of the effect.

BLEND - The dry/wet ratio of dry signal and delay.

MOD - The depth of modulation applied to the delay signal. The modulation rate is fixed via the C.V switch. There's also an option to extend the modulation with a Rate control which eliminates the toggle switch altogether.

C.V - This switches between chorus (slow) and vibrato (fast) type modulation.

Biasing Controls

BIAS1, 2 - These trimmers set the input bias voltage of the BBD chips.

GAIN1, 2 - These trimmers set the gain recovery after BBD1 and BBD2.

BAL - This trimmer balances the two outputs of the second BBD for minimum phase cancellation and clock bleed.

CLOCK - This timer sets the fine calibration for the maximum allowable delay time.

Terms of Use: You are free to use purchased **Skoolie** circuit boards for both DIY and small commercial operations. You may not offer **Skoolie** PCBs for resale or as part of a "kit" in a commercial fashion. Peer to peer re-sale is fine, though.

Technical assistance for your build(s) is available via the [madbeanpedals forum](http://madbeanpedals.com/forum). Please go there rather than emailing me for assistance on builds. This is because (1) I'm not always available to respond via email in a timely and continuous manner, and (2) posting technical problems and solutions in the forum creates a record from which other members may benefit.

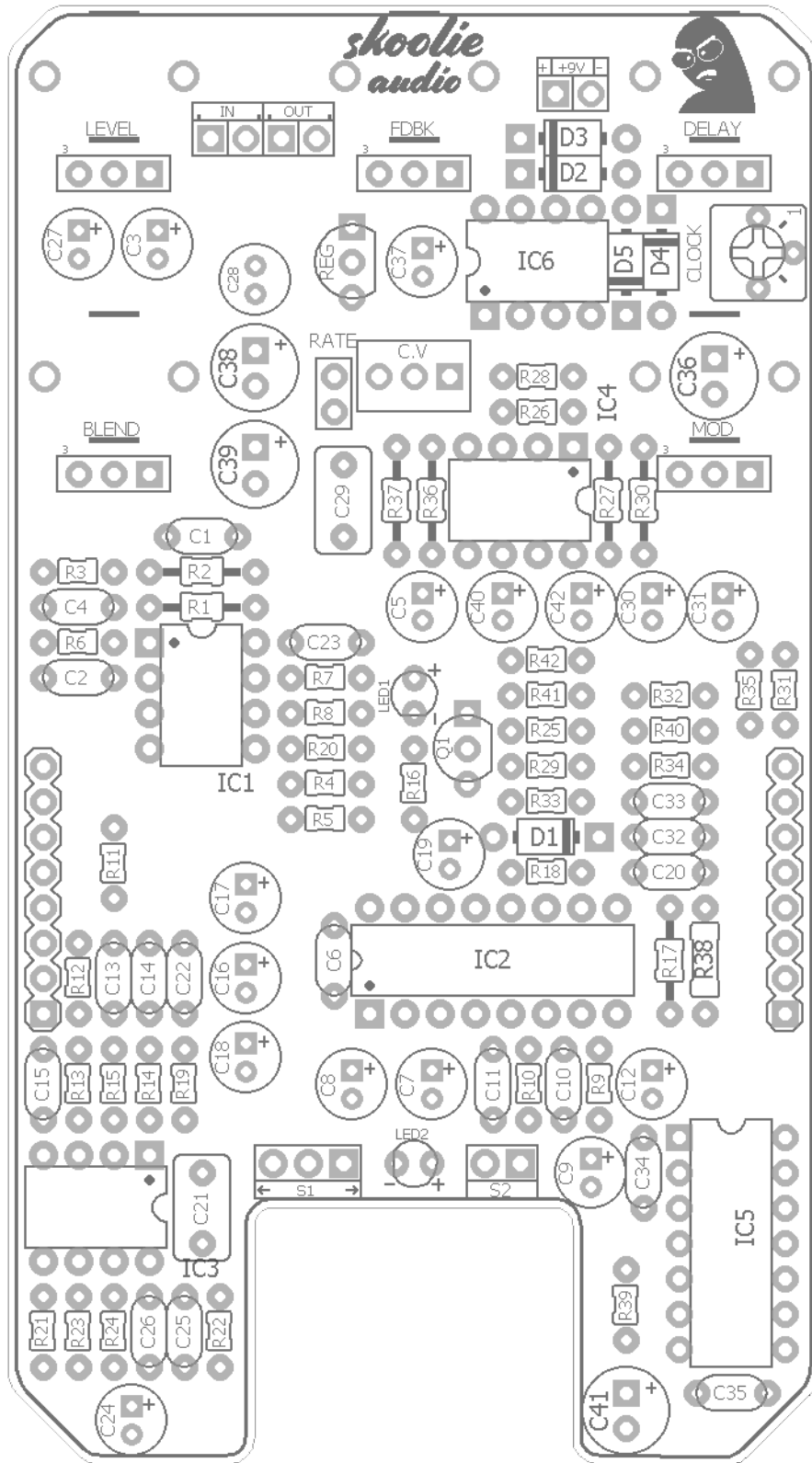

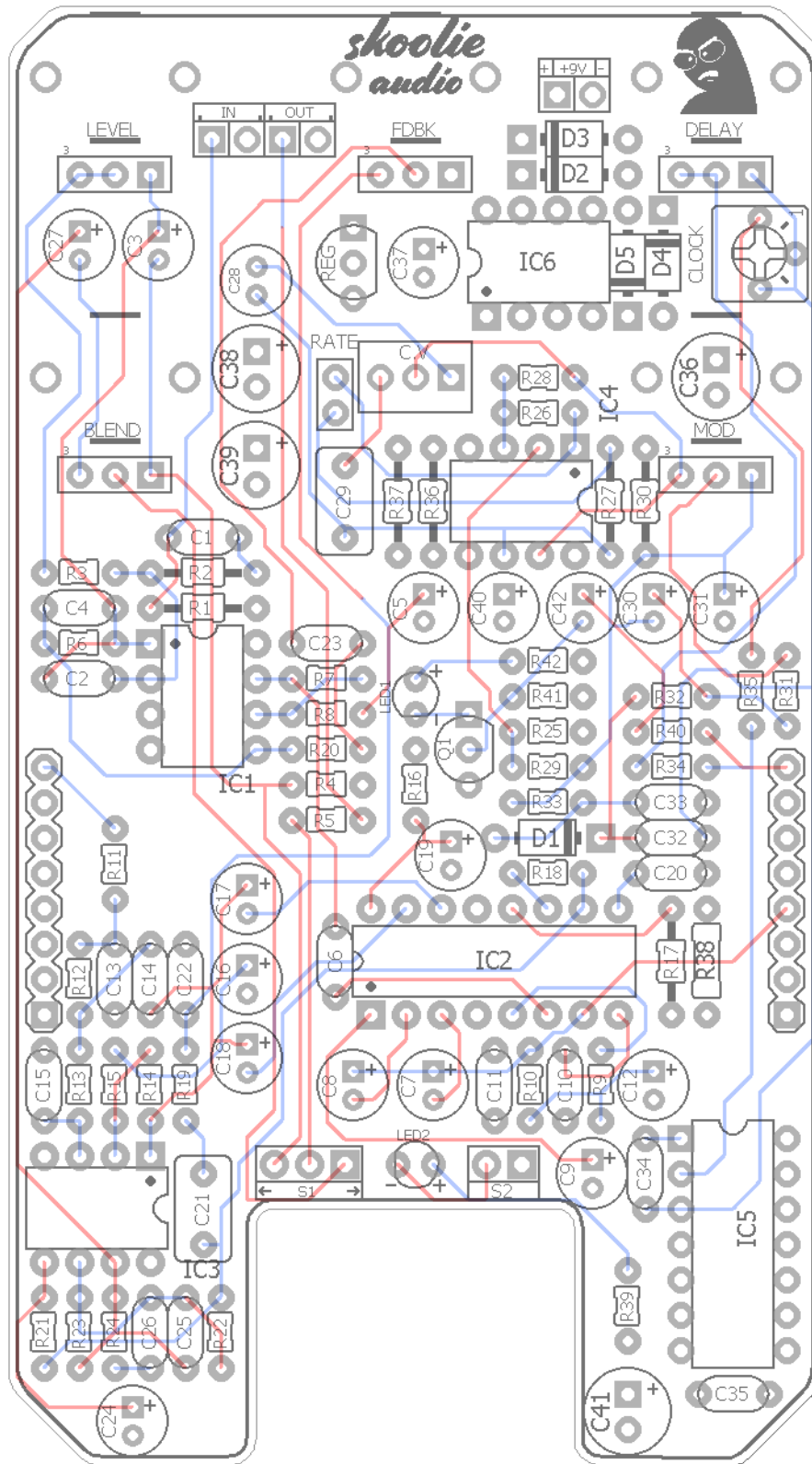

Signal layers (top and bottom)

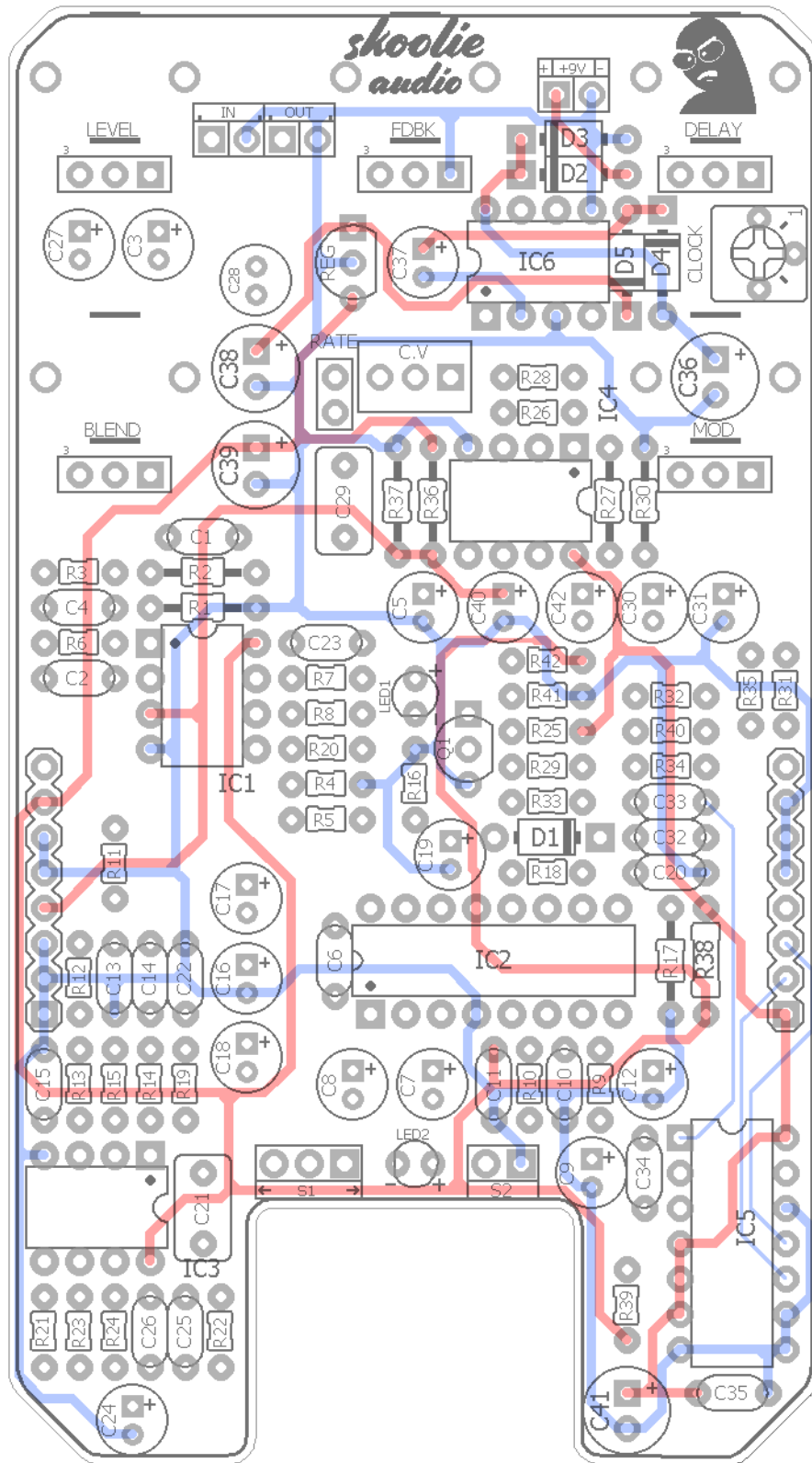

Power and ground (inner layers)

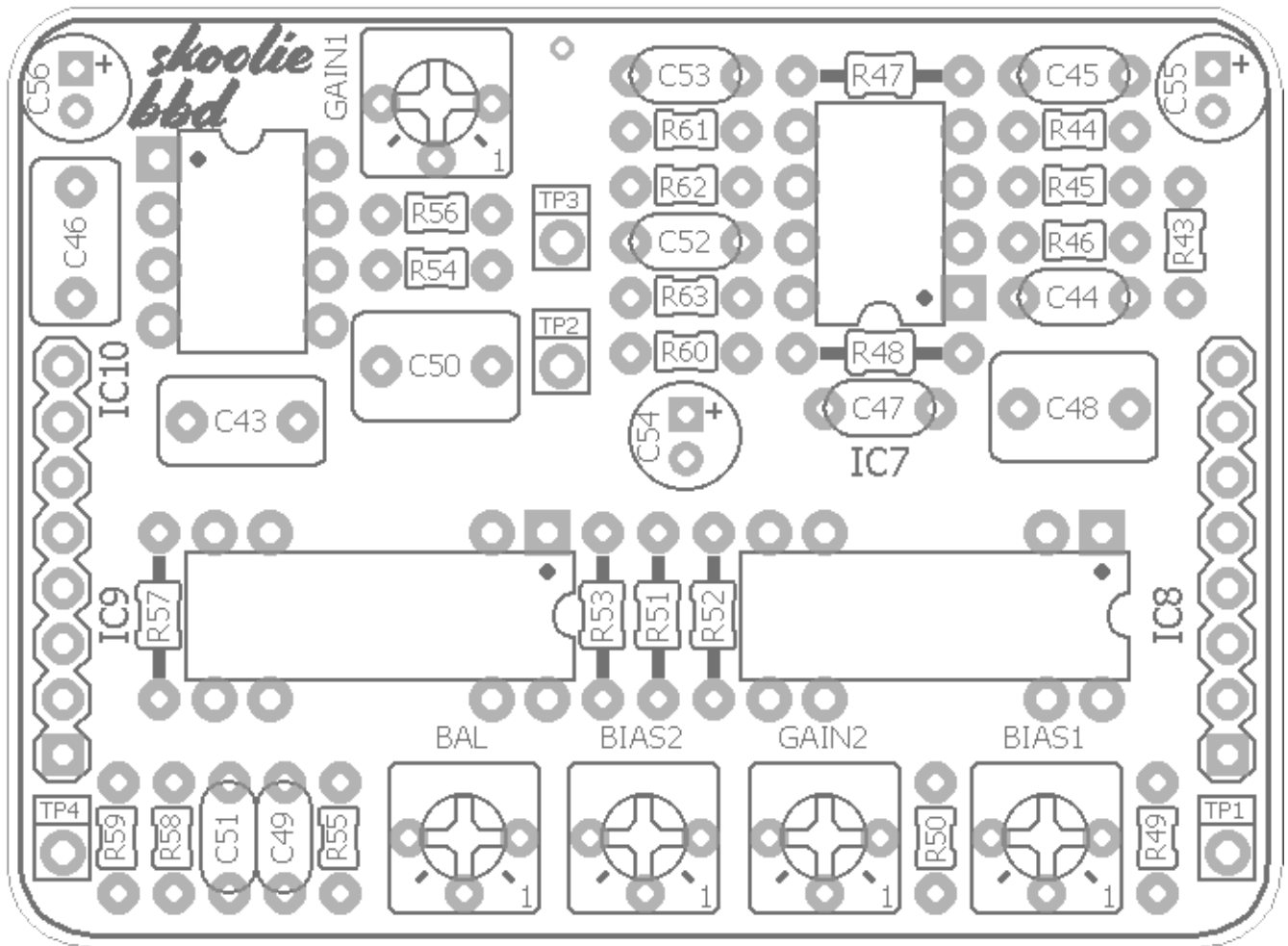

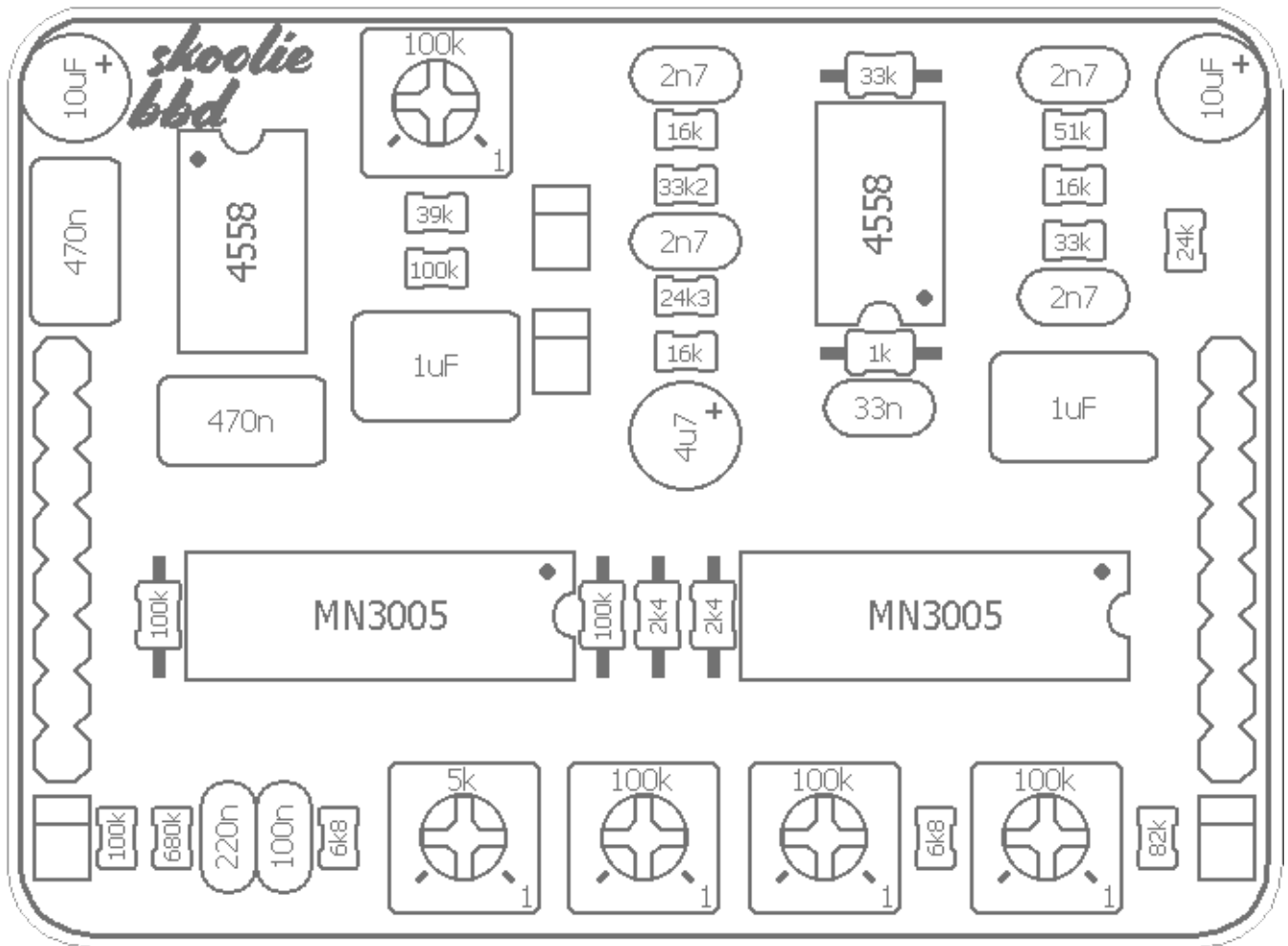

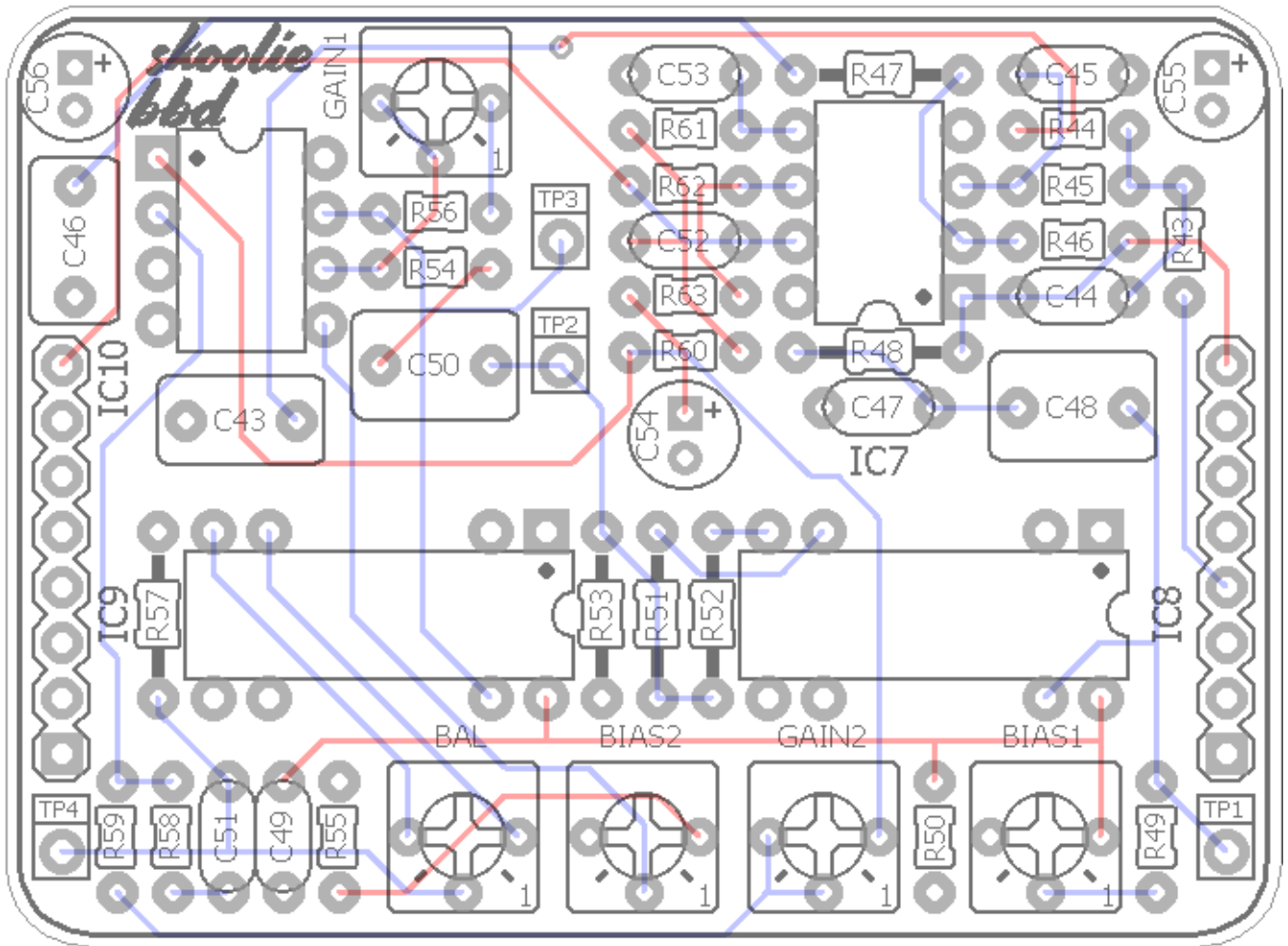

Signal layers (top and bottom)

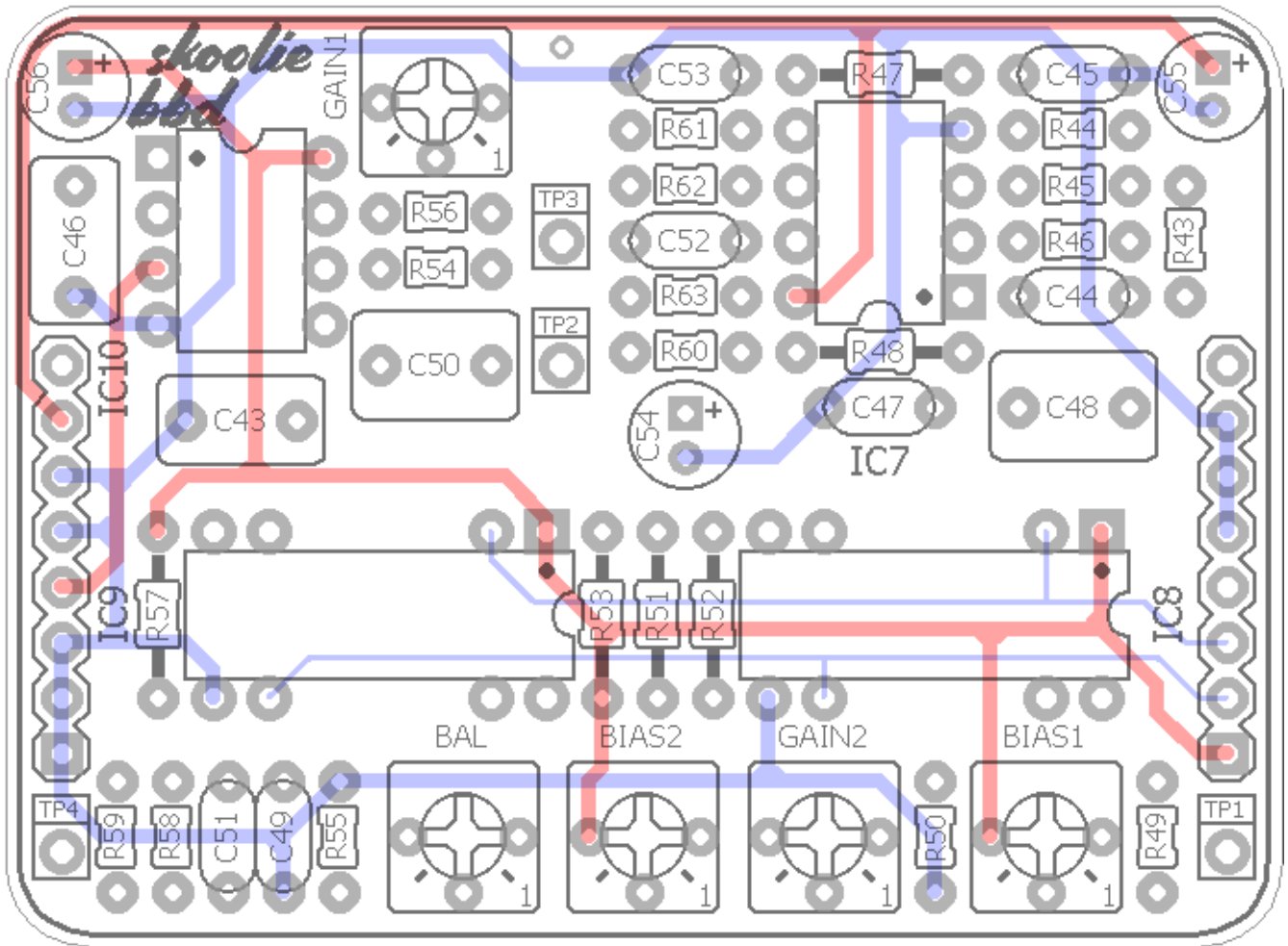

Power and ground (inner layers)

Resistors		Resistors		Caps		Caps		Pots	
R1	2M2	R40	10k	C15	2n7	C54	4u7	DELAY	500kB
R2	100k	R41	22k	C16	4u7	C55	10uF	FDBK	10kA
R3	22k	R42	1k	C17	1uF	C56	10uF	BLEND	10kB
R4	47k	R43	24k	C18	2u2	Diodes		LEVEL	1MA
R5	150R	R44	51k	C19	1uF	D1	1n4001	MOD	100kB
R6	100k	R45	16k	C20	3n9	D2	1n5817		
R7	200k	R46	33k	C21	470n	D3	15v Zener		
R8	200k	R47	33k	C22	47n	D4	1n5817		
R9	47k	R48	1k	C23	22n	D5	1n5817		
R10	47k	R49	82k	C24	1uF	LED1	Red 5mm		
R11	470R	R50	6k8	C25	150pF	LED2	5mm		
R12	15k	R51	2k4	C26	120pF	Transistors			
R13	16k	R52	2k4	C27	10uF	Q1	2n5088		
R14	15k	R53	100k	C28	2u2 BP	Regulator			
R15	39k	R54	100k	C29	470n	REG	78L15		
R16	10M	R55	6k8	C30	2u2	ICs			
R17	22k	R56	39k	C31	1uF	IC1	4558		
R18	20k	R57	100k	C32	1n	IC2	NE570		
R19	1k	R58	680k	C33	1n	IC3	4558		
R20	100k	R59	100k	C34	240pF	IC4	4558		
R21	100k	R60	16k	C35	100n	IC5	CD4047		
R22	240k	R61	16k	C36	220uF	IC6	LT1054		
R23	180k	R62	33k2	C37	47uF	IC7	4558		
R24	330k	R63	24k3	C38	100uF	IC8	MN3005		
R25	15k	Caps		C39	100uF	IC9	MN3005		
R26	910k	C1	100n	C40	47uF	IC10	4558		
R27	910k	C2	27pF	C41	100uF	Connectors			
R28	120k	C3	47uF	C42	22uF	HDR1, 2	Pins (8)		
R29	3k3	C4	1n2	C43	470n	HDR3, 4	Sockets (8)		
R30	13k	C5	1uF	C44	2n7	Switch			
R31	7k5	C6	220n	C45	2n7	C.V	On/On		
R32	27k	C7	4u7	C46	470n	Trimmers			
R33	27k	C8	2u2	C47	33n	BAL	5k		
R34	7k5	C9	1uF	C48	1uF	BIAS1	100k		
R35	120k	C10	omit	C49	100n	BIAS2	100k		
R36	100k	C11	100n	C50	1uF	GAIN1	100k		
R37	100k	C12	10uF	C51	220n	GAIN2	100k		
R38	22R	C13	47n	C52	2n7	CLOCK	500k		
R39	10k	C14	2n7	C53	2n7				

Value	QTY	Type	Rating	Value	QTY	Type	Rating
22R	1	Carbon / Metal Film	1/4W	3n9	1	Film	25v min.
150R	1	Carbon / Metal Film	1/8W	22n	1	Film	25v min.
470R	1	Carbon / Metal Film	1/8W	33n	1	Film	25v min.
1k	3	Carbon / Metal Film	1/8W	47n	2	Film	25v min.
2k4	2	Carbon / Metal Film	1/8W	100n	4	Film	25v min.
3k3	1	Carbon / Metal Film	1/8W	220n	2	Film	25v min.
6k8	2	Carbon / Metal Film	1/8W	470n	4	Film	25v min.
7k5	2	Carbon / Metal Film	1/8W	1uF	2	Film	25v min.
10k	2	Carbon / Metal Film	1/8W	1uF	6	Electrolytic	25v min.
13k	1	Carbon / Metal Film	1/8W	2u2	3	Electrolytic	25v min.
15k	3	Carbon / Metal Film	1/8W	2u2 BP	1	Electrolytic	25v min.
16k	4	Carbon / Metal Film	1/8W	4u7	3	Electrolytic	25v min.
20k	1	Carbon / Metal Film	1/8W	10uF	4	Electrolytic	25v min.
22k	3	Carbon / Metal Film	1/8W	22uF	1	Electrolytic	25v min.
24k	1	Carbon / Metal Film	1/8W	47uF	3	Electrolytic	25v min.
24k3	1	Carbon / Metal Film	1/8W	100uF	3	Electrolytic	25v min.
27k	2	Carbon / Metal Film	1/8W	220uF	1	Electrolytic	16v min.
33k	2	Carbon / Metal Film	1/8W	1n4001	1		
33k2	1	Carbon / Metal Film	1/8W	1n5817	3		
39k	2	Carbon / Metal Film	1/8W	15v Zener	1		
47k	3	Carbon / Metal Film	1/8W	LED	1	5mm Red	
51k	1	Carbon / Metal Film	1/8W	LED	1	5mm (any)	
82k	1	Carbon / Metal Film	1/8W	2n5088	1		
100k	10	Carbon / Metal Film	1/8W	78L15	1	TO-92	
120k	2	Carbon / Metal Film	1/8W	4558	5		
180k	1	Carbon / Metal Film	1/8W	CD4047	1		
200k	2	Carbon / Metal Film	1/8W	MN3005	2		
240k	1	Carbon / Metal Film	1/8W	NE570	1		
330k	1	Carbon / Metal Film	1/8W	LT1054	1		
680k	1	Carbon / Metal Film	1/8W	Pins	2	*included w/PCB	
910k	2	Carbon / Metal Film	1/8W	Sockets	2	*included w/PCB	
2M2	1	Carbon / Metal Film	1/8W	SPDT	1	Mini On/On	
10M	1	Carbon / Metal Film	1/8W	5k	1	Bourns 3362p	
27pF	1	Ceramic / MLCC	25v min.	100k	4	Bourns 3362p	
120pF	1	Ceramic / MLCC	25v min.	500k	1	Bourns 3362p	
150pF	1	Ceramic / MLCC	25v min.	10kA	1	PCB Right Angle	9mm
240pF	1	Ceramic / MLCC	25v min.	10kB	1	PCB Right Angle	9mm
1n	2	Film	25v min.	100kB	1	PCB Right Angle	9mm
1n2	1	Film	25v min.	500kB	1	PCB Right Angle	9mm
2n7	6	Film	25v min.	1MA	1	PCB Right Angle	9mm

I've created a Mouser project that has all the items highlighted in yellow on the Shopping List:

<https://www.mouser.com/ProjectManager/ProjectDetail.aspx?AccessID=a392c1b82e>

This includes the low-profile electrolytic caps needed on and underneath the BBD PCB.

Additional parts needed

1/8W Resistors:

<https://www.taydaelectronics.com/resistors/1-8w-metal-film-resistors.html>

v571:

<https://stompboxparts.com/semiconductors/v571d-dual-compander-ic/>

XVIVE MN3005:

<https://cabintechglobal.com/semi> (Under BBD section. They also have the v571 under Analog Signal Processing)

<https://synthcube.com/cart/xvive-mn3005-bbd-clone-ic-14-pin-dip-package?search=mn3005&description=true>

SPDT (On/On):

<https://smallbear-electronics.mybigcommerce.com/spdt-on-on-mountain-10tc410/>

<https://lovemyswitches.com/taiway-sub-mini-spdt-on-on-switch-pcb-mount-long-shaft/>

9mm PCB Right Angle Pots:

<https://stompboxparts.com/pots/9mm-potentiometer/>

<https://www.taydaelectronics.com/catalogsearch/result/?q=9mm+potentiometer>

DC Jacks:

<https://smallbear-electronics.mybigcommerce.com/dc-power-jack-all-plastic-unswitched-2-1-mm/>

<https://stompboxparts.com/power-connections/dc-power-jack-2-1mm-low-profile/>

<https://lovemyswitches.com/thinline-lumberg-dc-power-jack-2-1mm/>

1/4" jacks:

<https://lovemyswitches.com/1-4-mono-jack-lumberg-klbm-3/>

Sub - Lumberg Stereo Jack: <https://lovemyswitches.com/1-4-stereo-jack-lumberg-klb-3/>

My preferred 3PDT switch:

<https://lovemyswitches.com/pro-3pdt-latched-foot-switch-solder-lugs-feather-soft-click/>

Unless you have a substantial parts library, you will likely need to source items for this build from more than one vendor. This is complicated by a shortage of components due to supply chain issues. You can find everything you need, just not likely in a single shop.

To modify the Skoolie for extended modulation:

This uses a pot as a rate control instead of the two preset speeds you get from the toggle switch. To do this mod you will need:

- An additional 120k resistor (or 68k for redonkulous speeds).
- A [1MB or 1MC 9mm pot](#)
- You can omit one 470n cap and one 910k resistor from the Shopping List if you do the mod. See Notes for further explanation.

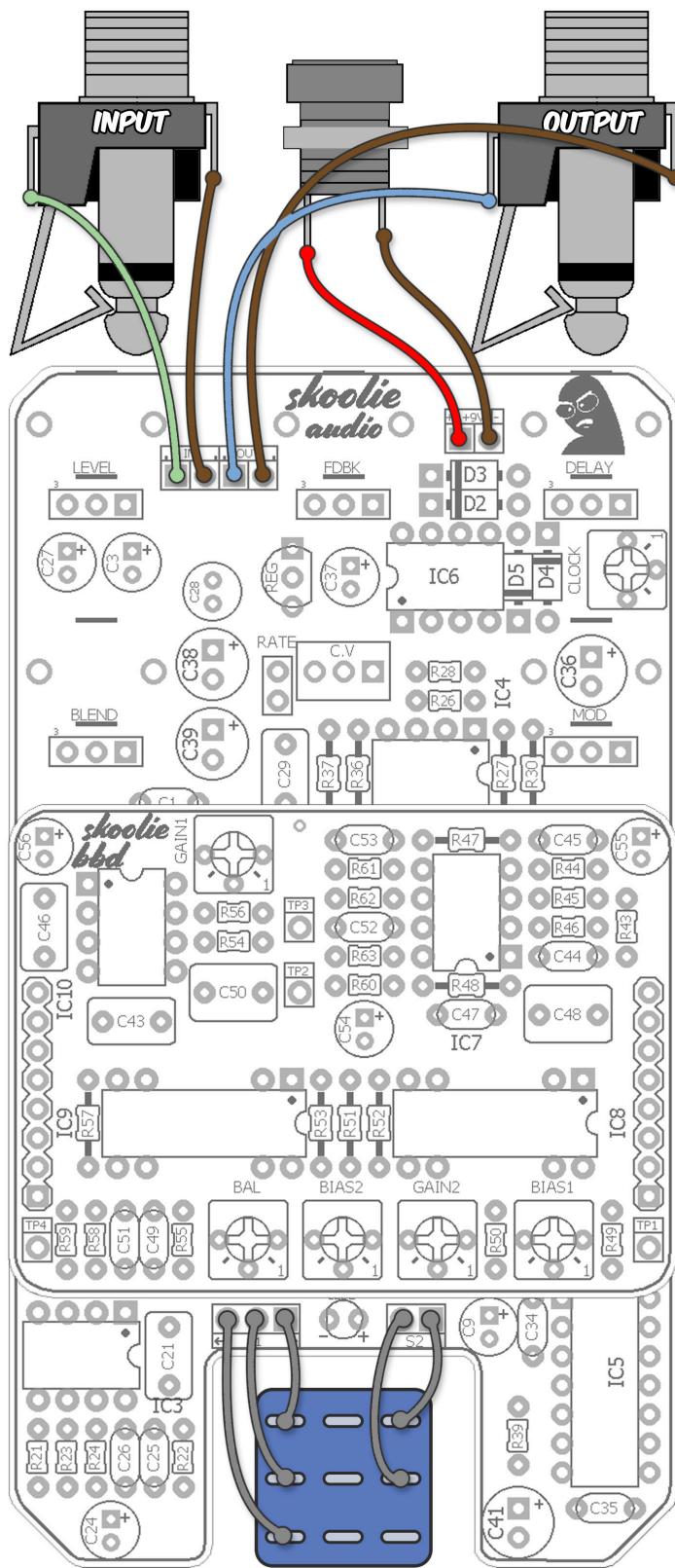

The middle row of the 3PDT is not used. The two LEDs are soldered directly to the Audio PCB.

Note: Drill Guides are approximate and may require tweaking depending on the types of jacks, switches and pots you use.

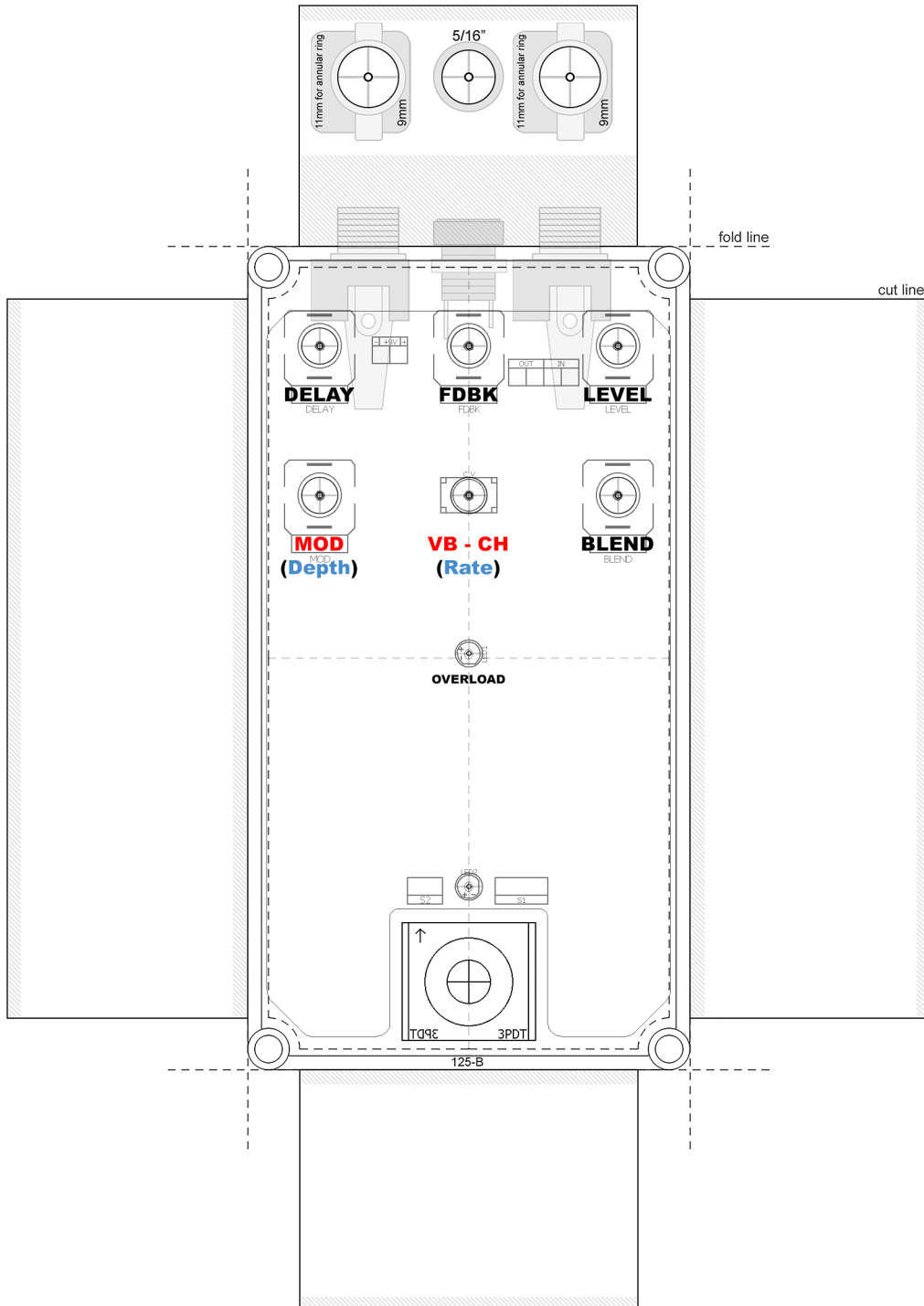

This template works for both the stock and extended modulations options. Stock controls are in red, extended modulation controls are blue. See the Notes section for further explanation.

IC1 4558		IC4 4558		IC7 4558		IC10 4558	
1	7.53	1	varies	1	7.82	1	7.53
2	7.54	2	7.85	2	7.84	2	7.52
3	7.51	3	7.82	3	7.79	3	7.52
4	0	4	0	4	0	4	0
5	7.44	5	7.85	5	7.5	5	7.93
6	7.52	6	7.85	6	7.52	6	7.95
7	7.53	7	varies	7	7.52	7	7.95
8	15.08	8	14.92	8	15.08	8	14.66
IC2 NE570		IC5 CD4047		IC8 MN3005		Q1 2n5088	
1	1.1	1	8.12	1	14.66	C	13.77
2	1.88	2	6.71	2	6.97	B	16mV
3	1.88	3	6.75	3	4.62	E	0
4	0	4	14.92	4	4.62	REG 78L15	
5	1.89	5	14.92	5	0	I	17.47
6	1.89	6	14.92	6	6.93	G	0
7	7.82	7	0	7	7.12	O	15.08
8	1.88	8	0	8	0.96		
9	1.88	9	0	IC9 MN3005			
10	8.16	10	7.44	1	14.66		
11	5.01	11	7.47	2	6.97		
12	1.89	12	0	3	5.25		
13	15.08	13	8.17	4	5.25		
14	1.89	14	14.92	5	0		
15	1.88	IC6 LT1054		6	6.93		
16	~450mV	1	2.31	7	7.95		
IC3 4558		2	4.95	8	0.96		
1	5.3	3	0				
2	5.3	4	5mV				
3	3.18	5	0				
4	0	6	2.56				
5	8.07	7	1.38				
6	8.15	8	9.19				
7	8.15						
8	15.08						

- 9.5vDC One Spot
- Current Draw: ~48mA
- Testing Conditions: All knobs @ 0
- Some results will vary depending on trimmer settings.
- I took the voltages readings on the Audio board without the BBD board attached. This means some voltages will be changed from their normal operational value. When taking voltages on your Audio board, leave your BBD board off for the most accurate comparison.

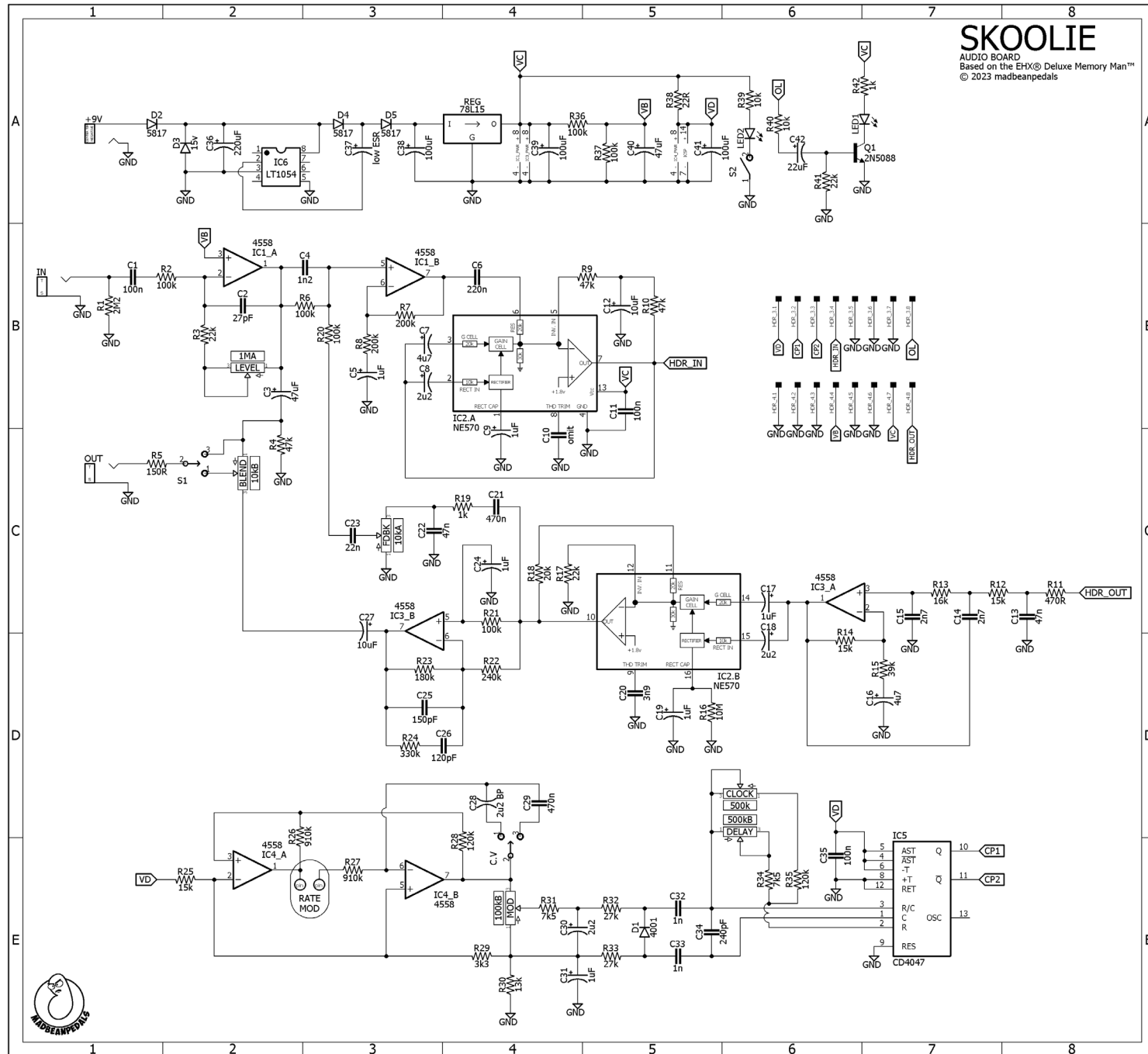

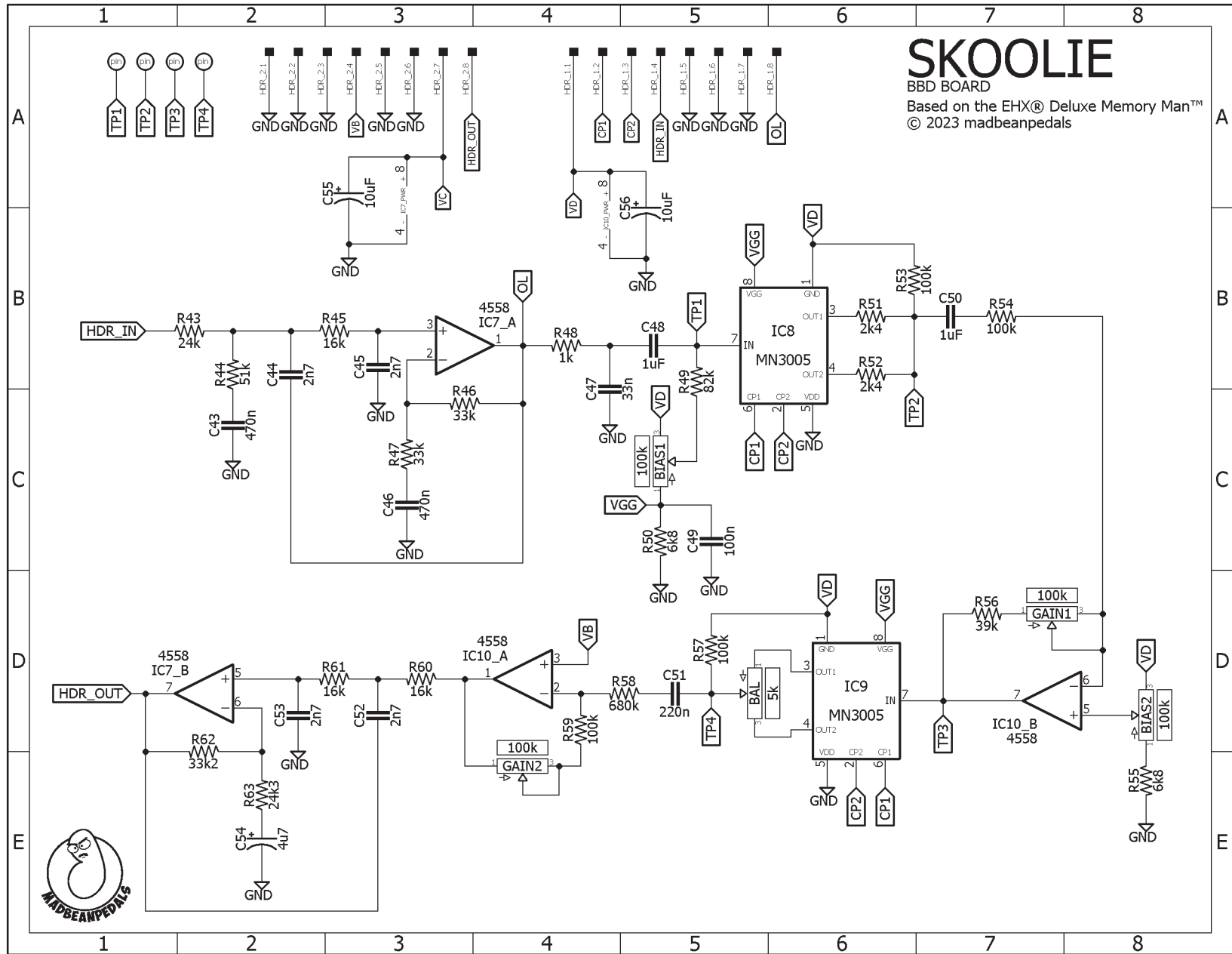

Before you begin your build, you should decide if you want to build the Skoolie with stock or extended modulation. To build it with stock modulation, simply follow the BOM as listed on pg.10. This means you will use a switch to select between two preset modulation speeds, where the speed is determined by the value of the integrator capacitor used in the LFO (2u2 BP and 470n, chorus and vibrato, resp.)

When building the Skoolie with the CV switch, you will need to jumper these two pads:

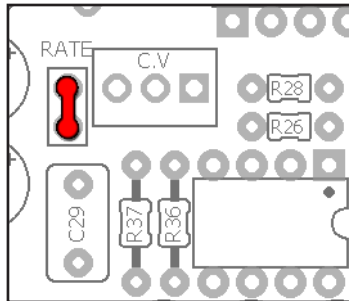

Extended Modulation Option

If you want full modulation control, then replace the CV switch with an pot. This gives all the in-between rate values plus faster speeds. You'll need to use a regular 9mm pot (not the PCB mounted type) and hand solder a couple of wires for the connection. Omit C29 and change R27 from 910k to 120k. You will also need to jumper two of the CV switch pads together, as shown below.

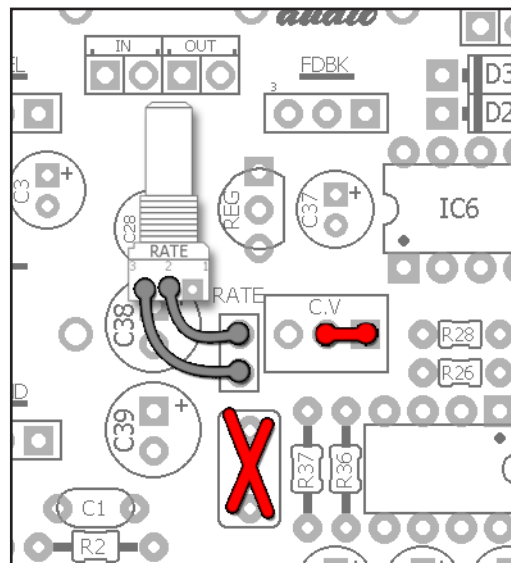

Shown from the top-side view of the 9mm pot (not the pin side)

As far as building the Skoolie, follow whatever order you like for populating and soldering both the Audio and BBD boards. But, don't solder in the pots/switch, headers, pin connectors or wires until later. We want to have a precise alignment between headers and pins so that the BBD and Audio boards seat well together.

In addition to the negative ground conversion, some additional mods were applied to the circuit. These enhance the operation without altering the fundamental delay tone we all love from the DMM.

Clock circuit

If you've built any of the other mbp DMM style projects, you know one caveat is that there was no way to adjust the BBD clock. This is why some vintage DMMs may have slightly different max delay times and in some cases clock noise at those settings. Previously, it was recommended to select a Delay pot that measured exactly 100k to prevent those issues.

The new clock circuit was copied directly from the mbp Prognosticator project (Stereo Memory Man™) and altered slightly in Delay pot and clock trimmer values to make it easier to dial in. The clock circuit is an additional adjustment but it guarantees that you can get the max delay time possible without any sort of artifact or dithering in the delay signal. And, it's easy to do.

Compander

All DMMs use DC coupled inputs on the compressor and expander portions of the NE570. For the Skoolie, these parallel inputs were decoupled at each input function. This is a very minor change but it's good practice, as I've learned. Two additional changes are boosting the output voltage of the expander to approximately V_b (7.5v) and a larger resistor in parallel with the RECT cap to prevent gating at high feedback settings. Some gating may still be present but only at the most extreme Delay and Feedback settings from what I've found. Overall, these changes seemed to work well in tandem with the negative ground conversion.

User Mods

There are two mods you can choose to perform, if you like:

1. Input impedance mod: The stock DMM has a very low input impedance directly into IC1 (100k). Ideally, we like to see something more like 470k or even 1M (actually, the absolute best route is to use a high impedance input buffer, then use much smaller value resistors for that gain stage to reduce noise but that's getting far and away from a traditional DMM). Long story short: increase the value of R2 to make the overall frequency response better to different pickup outputs. Just increasing this resistor to 220k would make a difference. For my build, I went a bit further. I used 300k for R2 and changed R3 from 39k to 100k. This does three things at once: increases input impedance, reduces the total gain output possible but at the same time reduces the likelihood of any nasty op-amp clipping at high Level settings; a good balance to address several shortcomings.
2. Noise reduction mod: Change all the 4558 to TL072 to lower the noise floor. There is a little bit of noise no matter what at high modulation settings (not ticking but frequency modulation noise) but it's not bad. At the very least, if you want to keep the 4558 for the sake of legitimacy then change IC4 to TL072 or maybe even a TL022.

After you have populated and soldered all the main components, but before you solder in the pots and toggle switch, let's deal with the headers and pins. Load one 8-pin header loosely onto the Audio board. I suggest folding alternating pins in an opposing pattern on the back of the PCB to secure them in place before soldering. Repeat for the second header on the opposite side.

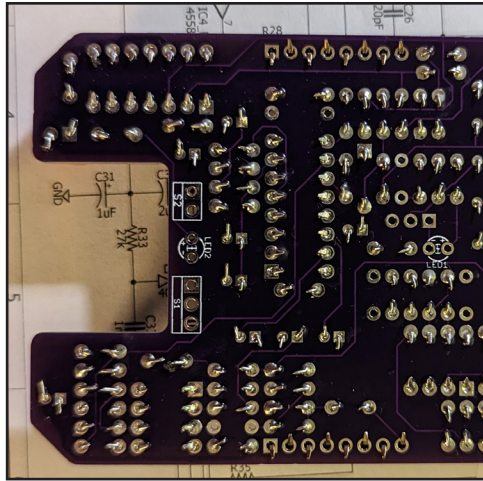

With the two headers soldered into place, insert the pins into each (long pins in, short pins exposed). Now place the BBD board loose onto the two pin strips. Solder the first and last pin of each row of pins.

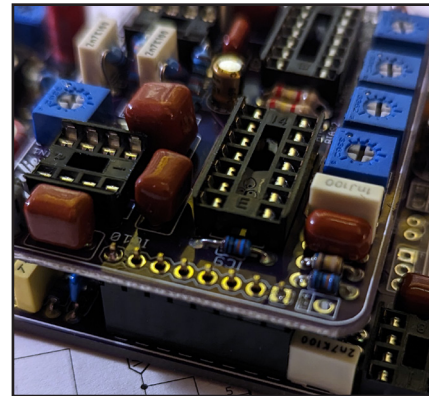
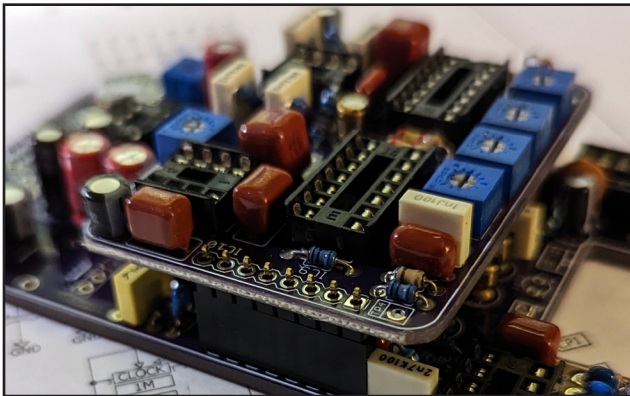

Remove the Daughter board and solder the remaining pins on both sides of the board. The reason we remove it is so the pins don't get too hot and melt the headers.

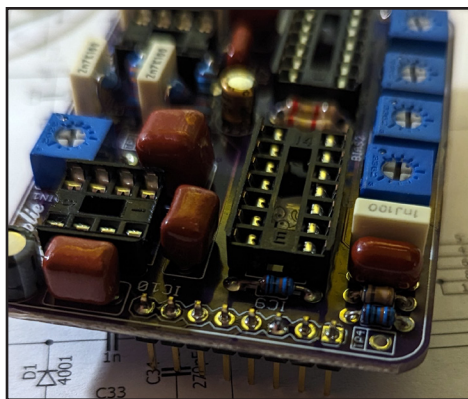

Once this is completed, you can load and solder the pots/switch and wires. You're ready to move onto the testing phase. You do not need to wire up the bypass switch but you do need wires soldered to the "S1" pads on the Audio board.

It's tempting, but don't jump right to loading all the ICs in and firing it up yet. Being a little bit methodical at the beginning of testing can potentially save a lot of guess work later on. And, obviously, do not box this build up until you are sure everything is working properly. Use whatever testing apparatus you have available. I used my Prototyping/Testing rig.

Follow this procedure (reminder - never load an IC when the PCB is powered. Always unplug power first!)

1. Leave the BBD board unplugged. Load in IC6, the LT1054 charge pump. Now connect 9v power.
2. Using your multimeter, verify you have about 9v on pin8 of IC6. Now check pin8 of the IC1 socket. You should be seeing about 15v. If so, go to step 3. If not, you will need to check over the charge pump circuitry and 15v regulator to see if you've made a mistake somewhere.
3. Disconnect power. Load IC1, IC2 and IC3 into their sockets and power back on. Check the voltage readings on pin8 of IC1 and IC3, and also pin13 on IC2. You should still see about 15v. If not, one of the ICs may be bad so you'll want to figure out which one and use a replacement.
4. At this point, we can check for audio even without the BBD board attached. Connect the wires soldered to pads 1 and 2 from the S1 bypass together (the two round pads). With your guitar or signal source plugged in the IN jack, you should hear audio from the OUT jack. Check the LEVEL control to see if it increases the output gain.
5. Power off. Load IC4 and IC5. Power back on and check pin8 of IC4 and pin14 of IC5 for 15v. Once you have verified all the voltages are good on the power pins of the Audio board we can go to the next step.
6. Power off and load IC7 and IC10 into the BBD board. Do not put in either MN3005 at this point. Attach the BBD board to the Audio board and power back on. Now check pins8 of IC7 and IC10 for 15v. Also, check pin1 of each MN3005 socket for *about* 15v as well. Finally, check pin8 of each MN3005 socket. You should read about 1v on both.

Testing is complete. Now you can move to the calibration stage!

This part requires an audio probe

This procedure is for “ear” calibration. You can get about 90% perfect calibration with this method. Perfect calibration will require an oscilloscope and if you have one, I suggest you follow the scope calibration guide in the Skoolie zip. I’ve done the ear calibration so many times I can legitimately say I can do it *almost* as good as a scope (except for the BAL trimmer). And if I can do that, then so can you!

Start with these settings

LEVEL pot & CLOCK trimmer: about 1/3rd up
 DELAY & BLEND: full up
 FDBK: full down
 MOD/DEPTH: full down
 RATE/CV switch: doesn’t matter
 All remaining trimmers: 1/2 up.

The BBD board has four testing points labeled TP1-TP4 (the “OL” label on the schematic is a connection back to the Audio board to feed the overload LED and not used for ear calibration). At this stage, we are going to do a rough calibration by ear. We’ll refine it later. You’ll want to have all ICs loaded except IC9.

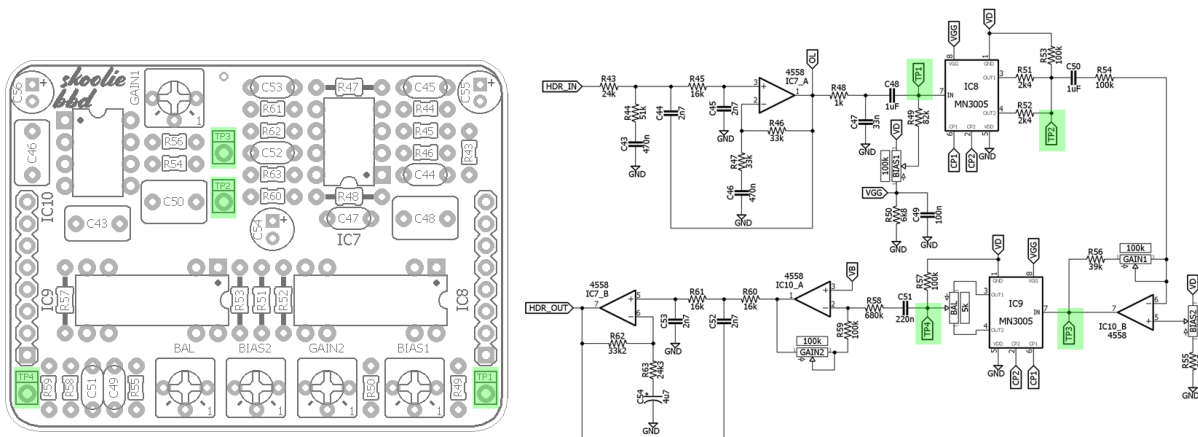

Use your guitar or a signal source plugged into the IN jack connection.

- Audio probe TP1 for signal. This verifies that audio is passing from the Audio to BBD board and the first BBD (IC8) is receiving input signal.
- Now probe TP2. Adjust BIAS1 until you get the cleanest delayed output possible. It’s usually around the middle of the trimmer.
- Go to TP3. Adjust GAIN1 so that audio level is about the same the level or slightly higher than at TP1.
- Power off and add IC9. Power back up.
- Go to TP4. Adjust BIAS2 until you get the cleanest delayed output possible from IC9. You may need to make a slight adjustment on GAIN1 to achieve this. Leave BAL and GAIN2 in the middle for the time being.

- At this point, you can check all the controls for function. Turn the FDBK knob up for multiple repeats and the BLEND to 1/2 to hear a mix of clean and delay signal. Check the DELAY knob range, check the MOD knob for modulation.
- Next we'll set the Skoolie for self-oscillation control. This means the delay signal adds to itself in a positive feedback cycle and each repeat increases in volume and distortion. Be careful with this since the volume level can get out of control quickly. Set the LEVEL control to about 1/3rd. Set the FDBK control to about 3/4th. Now adjust the GAIN2 trimmer back and forth so that the FDBK control goes into self-oscillation at its current setting. You can adjust and refine this setting to your liking. The "overload" LED should light up, as well.
- Make any final adjustments to the trimmers to improve the level and clarity of the repeats. You cannot adjust the BAL trimmer by ear, so leave it in the middle.
- Set the Delay to max and feedback about 1/2 up. Listening to the delay repeats adjust the CLOCK trimmer clockwise for the maximum allowable delay without any sort of artifact in the tone. When you go too far, the delay repeats will have a "bit crushed" type quality. Leave the trimmer at the setting just before this becomes apparent. You should have roughly 550ms of delay.
- This completes calibration "by ear".

For reference, the clock range (measured at any CP1 or CP2 connection) on my build is:
Min delay: ~75kHz / Max delay: ~8.4kHz

For calibration with an oscilloscope, I've included an additional pdf document in the Skoolie .zip file.

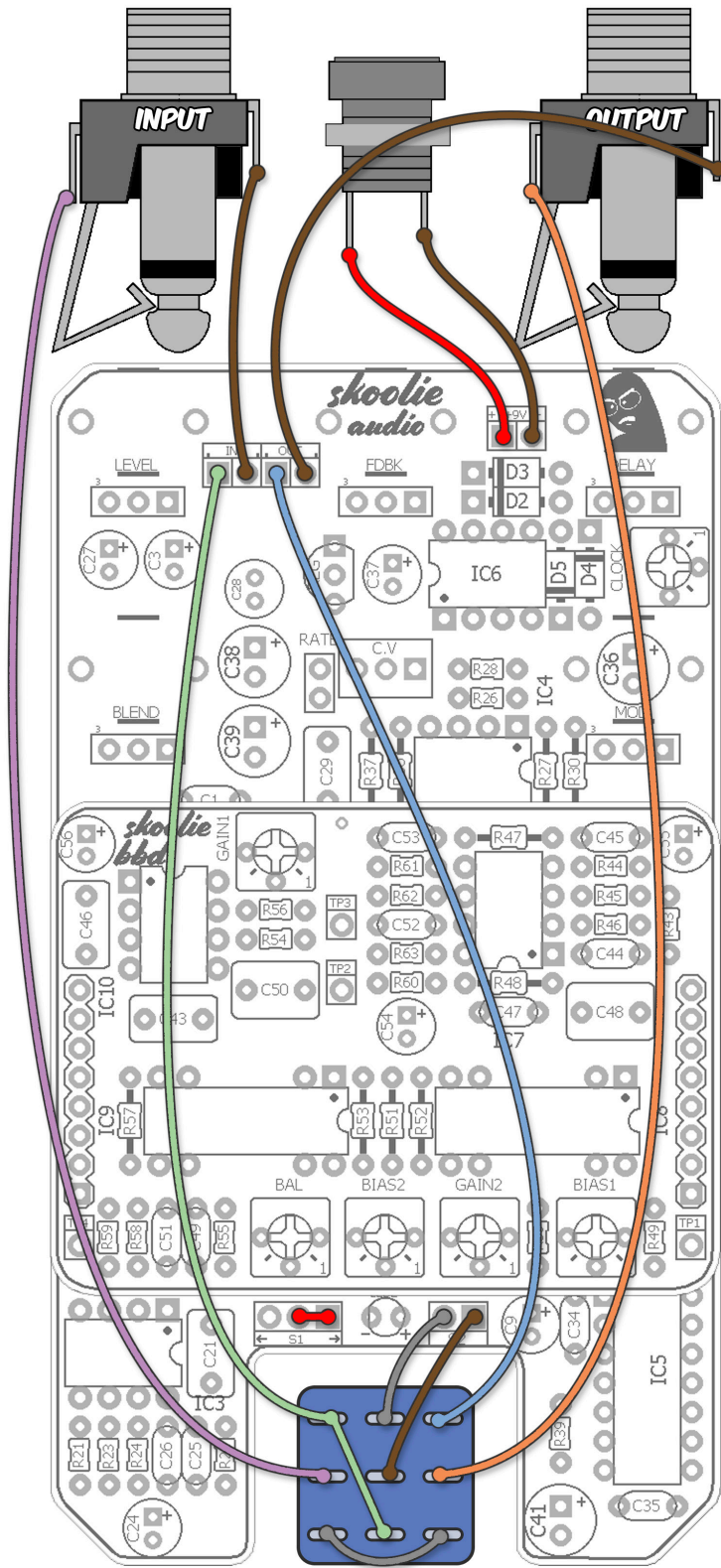

Use this wiring diagram if you prefer true bypass operation. This will disable the LEVEL control in bypass.

This info is copied from the Total Recall documentation to use as a reference. Some of the component numbering and procedures may be different than the Skoolie.

There are two ways to bias the Total Recall. One is by ear and the other is with an oscilloscope. This document will show you how to do it by ear. For scope biasing there are a few guides online the give lots of detail on how to do the procedure.

Here is one guide you might find useful for scope calibration (this info in also available in the TourbusScope.pdf in the project .zip file): <https://sites.google.com/a/davidmorrin.com/www/home/trouble/troubleeffects/electro-harmonix-memory-man/eh-7850/eh-7850-calibration>

Before biasing, let's understand what we are doing and why. The bucket-brigade device (BBD) requires a bias voltage applied to its input in order to pass a delayed signal. This is done via a trimmer set up as a voltage divider connected to the power supply. An audio source is applied to the BBD input (pin7) and the trimmer is adjusted until we get a result on the two outputs of the chip (pins 3 and 4). The output is the delayed signal where the delay time is controlled by the two out-of-phase clock signals (pins 2 and 6) generated by the CD4047 and processed through the sequential "bucket" steps. The two outputs are mixed together and then sometimes sent to a gain recovery stage. This helps make up any volume loss introduced by the sequential steps in the BBD (2048 steps for MN3008 and 4096 for MN3005). After the gain recovery, the signal is sent to the next BBD and the same process is repeated.

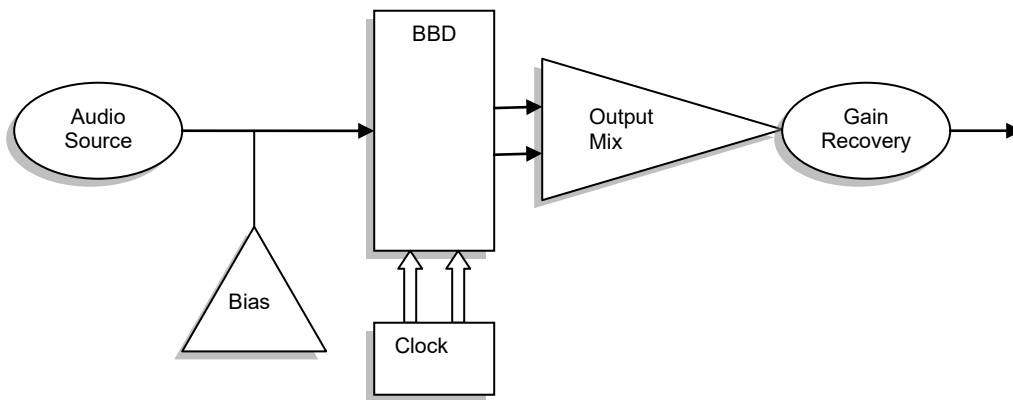

Let's compare that to a circuit snippet from the TR schematic.

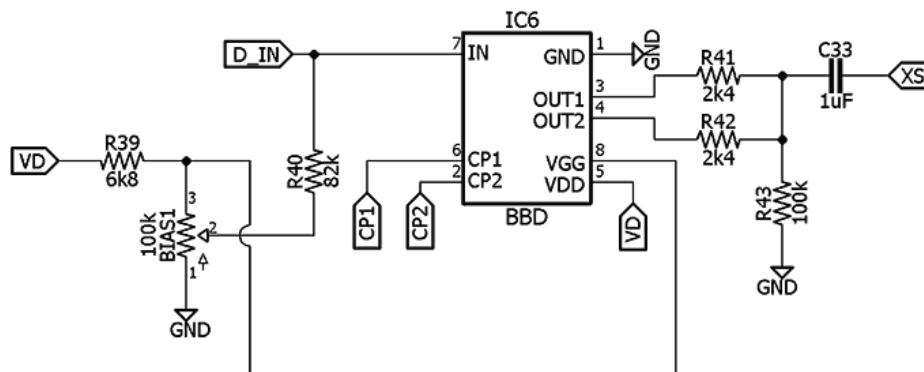

Our audio source comes in at D_IN and goes to pin7 of IC6. BIAS1 is our voltage divider, also connected to pin7. CP1 and CP2 are the two clock signals, pins1 and 5 are ground and power resp., pin8 is the Vgg voltage (in this case it is set to -14vDC) and our outputs come from pins 3 and 4. These are mixed with another voltage divider created by R41 - R43.

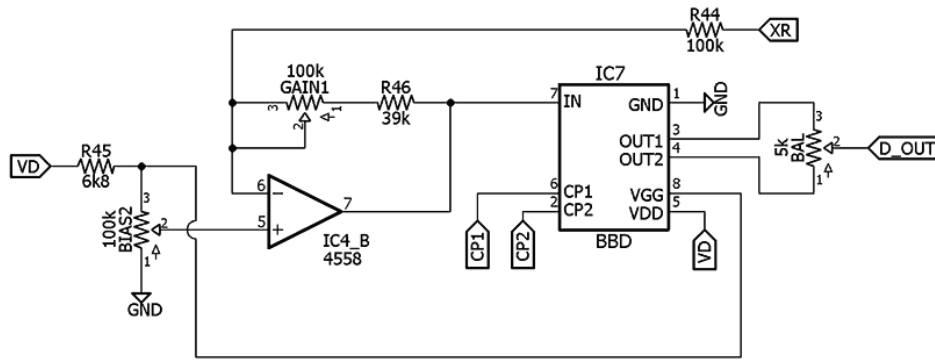

The gain recovery stage starts at XR. It is fed through an inverted gain stage with a trimmer to adjust the output volume. Here the biasing is done differently with the bias voltage applied to the non-inverted input of the op-amp. At the outputs, we have a new trimmer, BAL. This trimmer is used to align the two output waveforms for minimum phase cancellation and minimal clock bleed. After the BAL trimmer the signal gets sent to the second and final gain recovery stage.

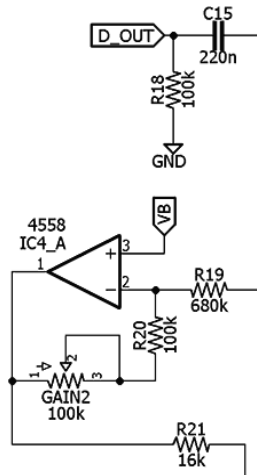

After the second gain recovery stage, the signal is sent through additional filters, the expander, then mixed to the output of the circuit (not shown).