

CLIFFHANGER

FX TYPE: Compressor

Based on the Hermida® Dover Drive™

Enclosure Size: 125B

Softie compatibility: Softie3

© 2021 [madbeanpedals](http://madbeanpedals.com)



Overview

The **Cliffhanger** is built off the Hermida® Dover Drive™ which is marketed as “spiritual” Chandler® Tube Driver™ in a discrete package. This might be a bit of a stretch since the two circuits have almost nothing in common. But, that doesn’t mean the DD is not a great sounding hybrid overdrive. Combining a silicon fuzz in front of a Zendrive™ circuit does produce delicious tones and does get somewhat into that Gilmour/EJ territory. The thing that strikes me about the design is the use of PNP transistors on the front end of the circuit. I’m curious as to why that approach was used over the typical NPN version of a Fuzz Face. It’s not because the circuit uses esoteric transistors for the fuzz - they are plain ‘ol 2n3906. Possibly it was done to include the option for germanium transistors at some point. AFAIK, there are no DD with this option.

In any case, I’ve taken a lot of liberties with the Cliffhanger. All the DD elements are there but I’ve done a few mods on the front end, power section and put in some extra tweaking controls that I think will appeal to DIY’ers.

Controls

- **FUZZ** - Sets the fuzz amount before the overdrive circuit. This control may produce some zipper noise when turned and it’s normal (most likely from the DC across the pot).
- **COMP** - Alters the bias of Q3. When turned CW compression will increase to squash the fuzz all the way into a buzzing bee.
- **PRE** - This trimmer sets the fuzz output volume before the overdrive circuit. Tweak to taste.
- **VOICE** - This trimmer adds the “Voice” control on the Zen Drive. As it is turned CW the overdrive circuit will clip lower end frequencies while reducing the total gain. Its fairly limited in use.
- **TONE** - A simple low pass filter directly after the overdrive clipping stage.
- **VOL** - Effect output level.
- **S/M** - Left (stock): Dover Drive™. Right (modded): adds an additional input gain stage for a brighter and more mids-focused tone. This also translates very well when rolling off the guitar volume.

Terms of Use: You are free to use purchased **Cliffhanger** circuit boards for both DIY and small commercial operations. You may not offer **Cliffhanger** PCBs for resale or as part of a “kit” in a commercial fashion. Peer to peer re-sale is fine, though.

Technical assistance for your build(s) is available via the [madbeanpedals forum](http://madbeanpedals.com). Please go there rather than emailing me for assistance on builds. This is because (1) I’m not always available to respond via email in a timely and continuous manner, and (2) posting technical problems and solutions in the forum creates a record from which other members may benefit.

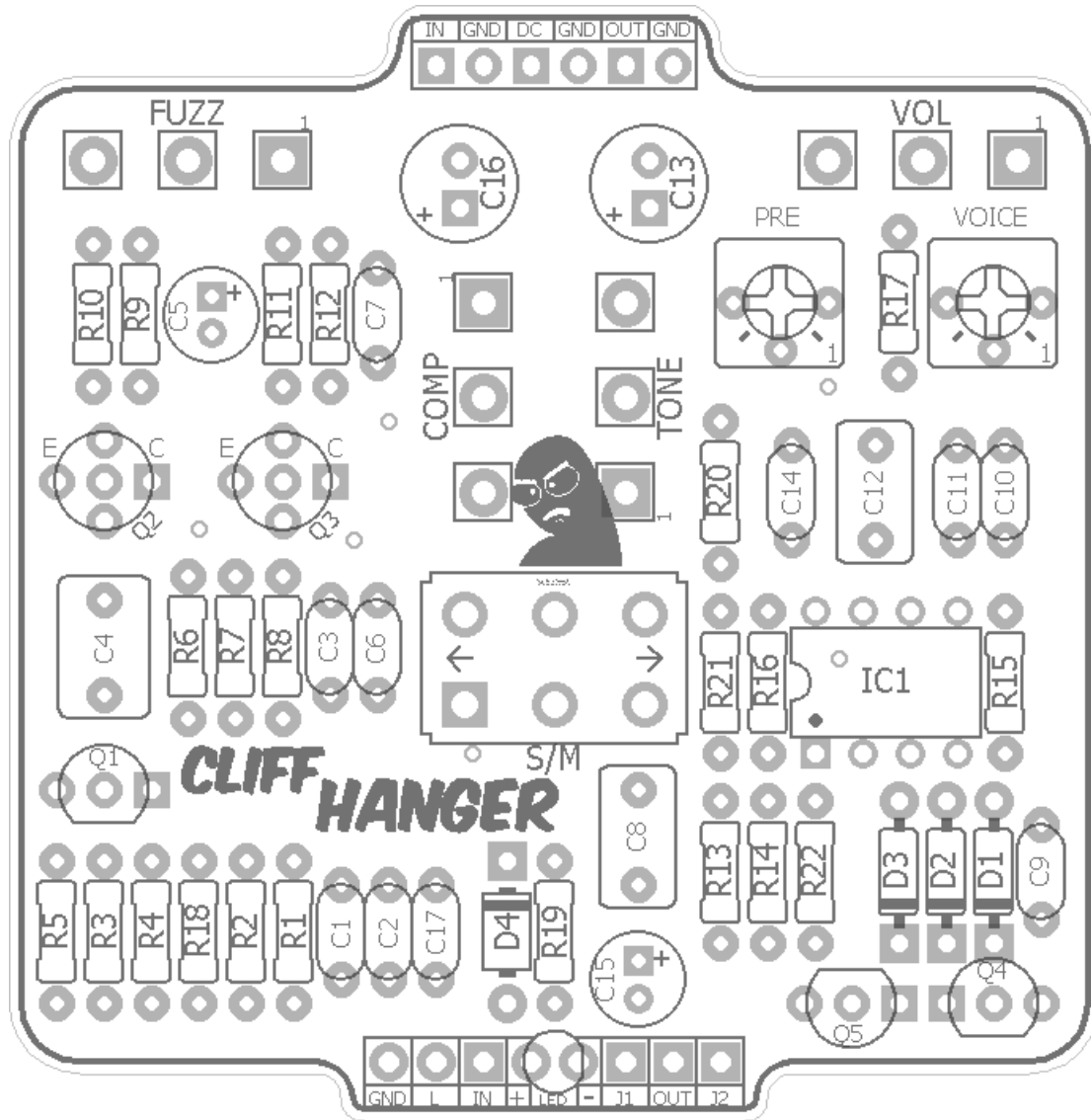

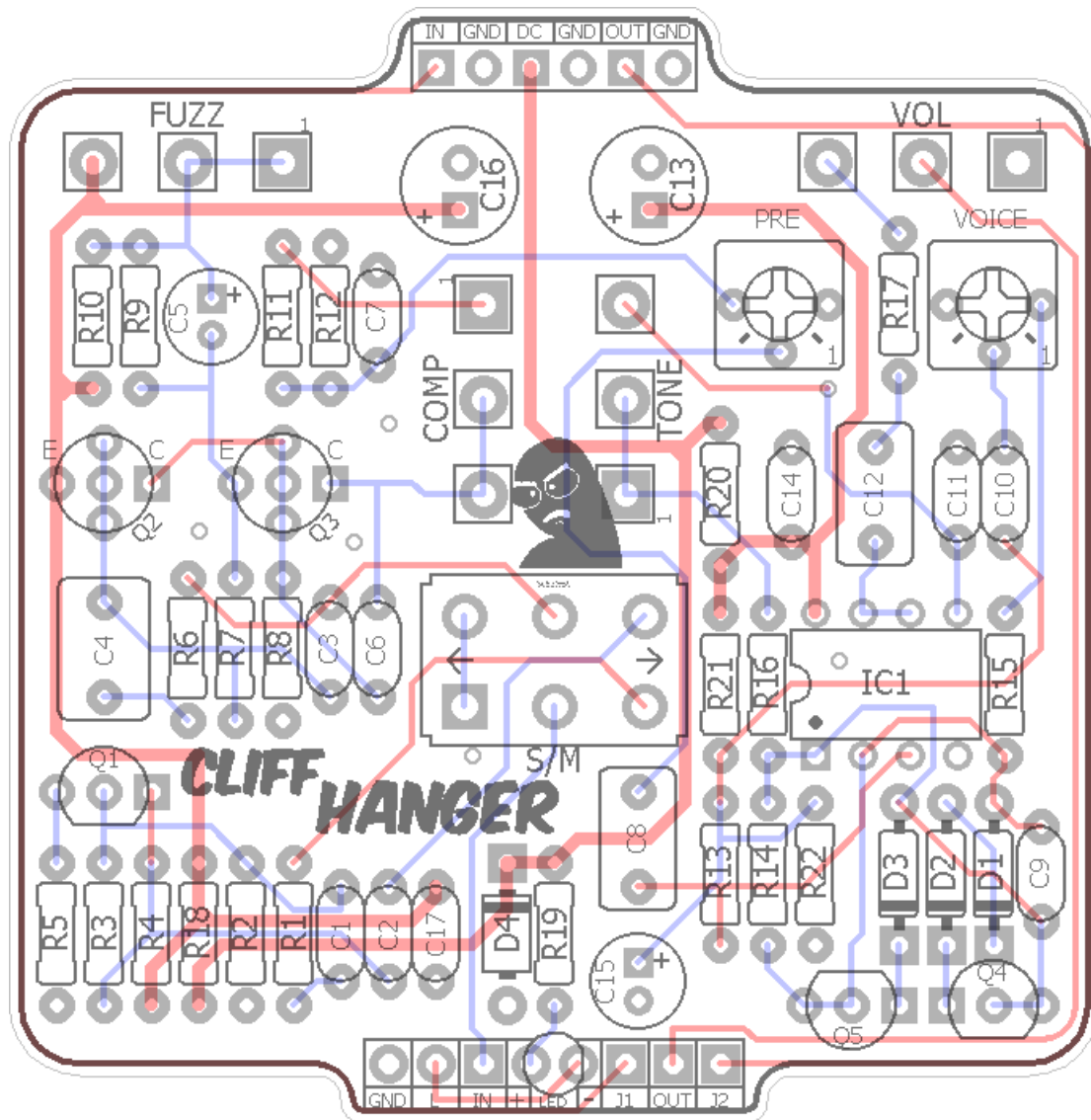

Resistors		Caps		Diodes	
R1	1k	C1	100n	D1	BAT46
R2	100k	C2	10n	D2	1n34a
R3	470k	C3	4n7	D3	BAT46
R4	10k	C4	1uF	D4	1N4001
R5	2k7	C5	22uF	Transistors	
R6	33k	C6	see notes	Q1	2n3904
R7	100k	C7	100n	Q2	Si PNP
R8	33k	C8	470n	Q3	Si PNP
R9	1k	C9	100pF	Q4	2N7000
R10	1k	C10	100n	Q5	2N7000
R11	2k2	C11	3n3	ICs	
R12	470R	C12	470n	IC1	NE5532
R13	470k	C13	100uF	Switches	
R14	220k	C14	100n	S/M	On/On
R15	1k	C15	22uF	Trimmers	
R16	10k	C16	100uF	VOICE	10k
R17	1k	C17	100n	PRE	200k
R18	330R			Pots	
R19	4k7			FUZZ	1kC
R20	100R			COMP	10kA
R21	10k			TONE	50kC
R22	10k			VOL	100kA

Q2 and Q3 are 2n3906 in the stock unit. See the Notes section for suggestions on alternatives.

Value	QTY	Type	Rating
100R	1	Metal / Carbon Film	1/4W
330R	1	Metal / Carbon Film	1/4W
470R	1	Metal / Carbon Film	1/4W
1k	5	Metal / Carbon Film	1/4W
2k2	1	Metal / Carbon Film	1/4W
2k7	1	Metal / Carbon Film	1/4W
4k7	1	Metal / Carbon Film	1/4W
10k	4	Metal / Carbon Film	1/4W
33k	2	Metal / Carbon Film	1/4W
100k	2	Metal / Carbon Film	1/4W
220k	1	Metal / Carbon Film	1/4W
470k	2	Metal / Carbon Film	1/4W
100pF	1	Ceramic / MLCC	16v min.
3n3	1	Film	16v min.
4n7	1	Film	16v min.
10n	1	Film	16v min.
100n	5	Film	16v min.
470n	2	Film	16v min.
1uF	1	Film	16v min.
22uF	2	Electrolytic	16v min.
100uF	2	Electrolytic	16v min.
BAT46	2		
1n34a	1		
1N4001	1		
2n3904	1		
Si PNP	2	*see notes	
2N7000	2		
NE5532	1		
On/On	1	DPDT, PCB Pin	
10k	1	Bourns 3362p	
200k	1	Bourns 3362p	
1kC	1	PCB Right Angle	16mm
10kA	1	PCB Right Angle	16mm
50kC	1	PCB Right Angle	16mm
100kA	1	PCB Right Angle	16mm

You can sub a linear taper for the 1k, 10k and 50k 16mm pots. I preferred the tapers listed but it's not totally necessary.

1n34a SUB:

<https://smallbear-electronics.mybigcommerce.com/diode-nos-germanium/>

1n34a are OoS on smallbear. You can sub another BAT46 in place of the 1n34a.

BAT46:

<https://smallbear-electronics.mybigcommerce.com/diode-schottky-bat46/>

2n3904:

<https://smallbear-electronics.mybigcommerce.com/transistor-2n3904/>

2n3906:

<https://smallbear-electronics.mybigcommerce.com/transistor-2n3906/>

NE5532:

<https://smallbear-electronics.mybigcommerce.com/ic-ne5532p/>

DPDT (On/On):

<https://smallbear-electronics.mybigcommerce.com/dpdt-on-on-short-lever-pc-mount/>

Bourns 10k:

<https://www.taydaelectronics.com/potentiometer-variable-resistors/cermet-potentiometers/3362p/10k-ohm-trimmer-potentiometer-cermet-1-turn-3362p.html>

Bourns 200k:

<https://www.taydaelectronics.com/potentiometer-variable-resistors/cermet-potentiometers/3362p/200k-ohm-trimmer-potentiometer-cermet-1-turn-3362-3362p.html>

16mm pots:

<https://smallbear-electronics.mybigcommerce.com/alpha-single-gang-16mm-right-angle-pc-mount/>

Thinline DC Jack:

<http://smallbear-electronics.mybigcommerce.com/dc-power-jack-all-plastic-unswitched-2-1-mm/>

Mono Jacks:

<http://smallbear-electronics.mybigcommerce.com/lumberg-1-4-compact-shrouded-mono-jack/>

<http://smallbear-electronics.mybigcommerce.com/1-4-in-mono-nys229/>

<https://smallbear-electronics.mybigcommerce.com/1-4-in-mono-enclosed-switchcraft-111x/>

- The stock unit uses 2n3906 for Q2 and Q3. These are perfectly fine for a fuzz circuit. Whether or not they are sorted for gain by the manufacturer is unknown. I tried them and thought they sounded okay. But, I also tried alternatives which I liked much better. For my build I used 2n3644 which are PNP devices but lower gain than the 3906. I sorted the few I had on hand and went with HFE of 88 and 118 for Q2 and Q3, resp.
- Smallbear has a ton of these: <https://smallbear-electronics.mybigcommerce.com/transistor-2n3644-fairchild/>
- They also have plenty of other mojo infused PNP devices which you can find in this category (note some are NPN which you cannot use in this build): <https://smallbear-electronics.mybigcommerce.com/to-106-to-109-and-to-110-dots-1/>
- The PCB has a multi-pin layout for Q2 and Q3 so you can use different transistor pinouts depending on what you choose. The pads in the center of each are all Base.

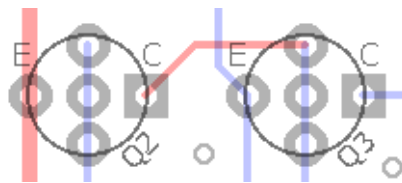

- C6 doesn't list a value. I added this cap to include an option to quiet down noisy transistors, if needed. It is not required but available should you want it. Typical values used here range from 47pF up to 220pF, with larger values producing more high end roll-off. You should socket this cap.
- The stock unit uses two fixed resistors in place of the PRE trimmer. I chose a trimmer here for more control. With low PRE settings, less fuzz output is sent to the overdrive clipping stage input. This is a good setting if you prefer something a bit tamer. As you increase the PRE trimmer, the effect output will get thick and creamy but it will also increase the noise floor. I preferred mine set at about 40% up.
- The VOICE trimmer is taken directly from the Zen Drive, since that is what the overdrive stage is based on. It replaces a fixed 4k7 resistor so the stock setting on the Cliffhanger is about 40% up. My preference ended up being the stock setting.
- With the Tone control fully clockwise (brightest setting) the LPF starts at about 4.8kHz. This is a bit overkill, IMO. If you want a little more range from the tone control then lower R16. I tried 4k7 and 2k2 and both seemed to do the job. Socket this resistor if you want to experiment. I stuck with 2k2.

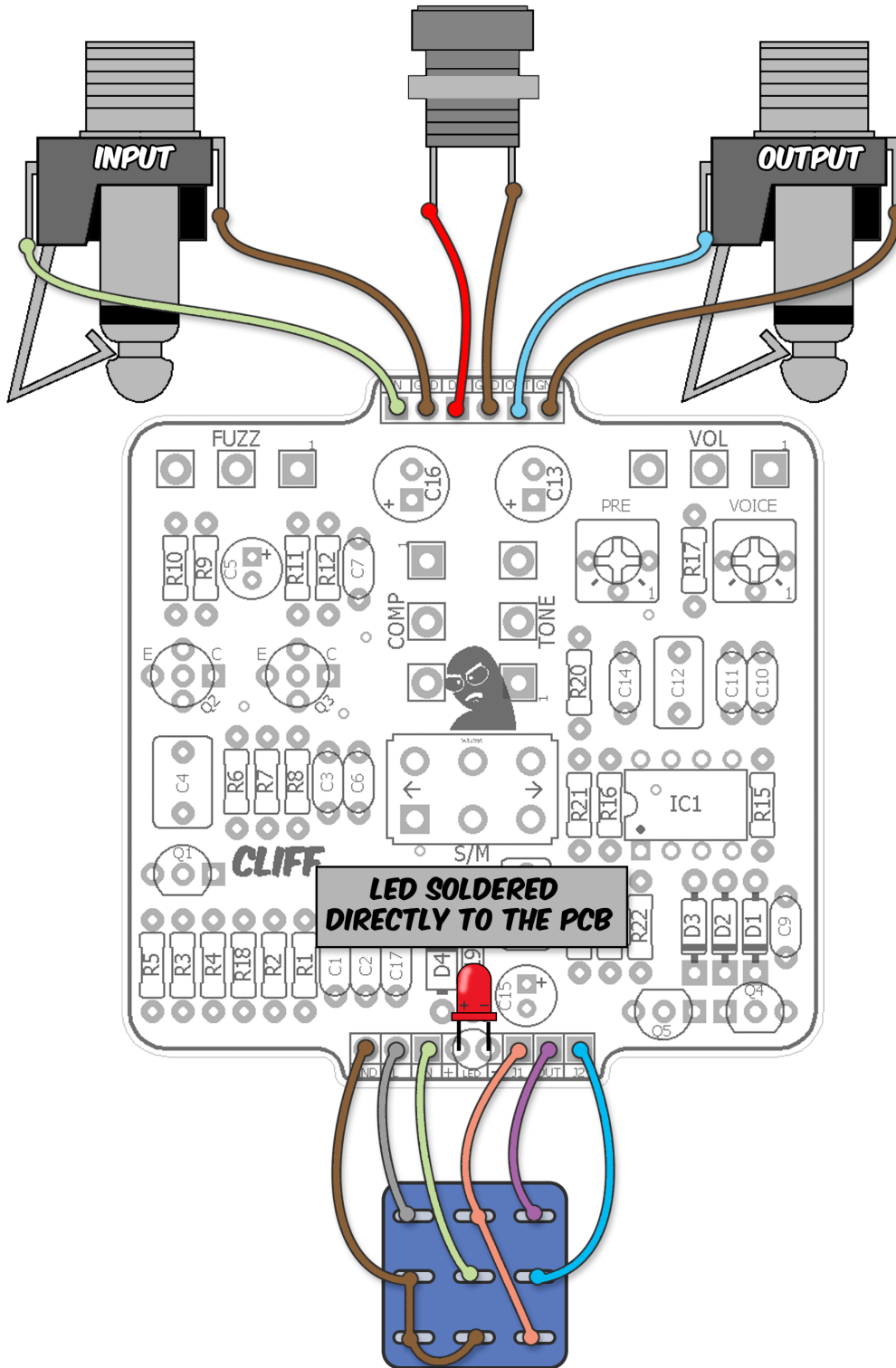

3PDT bypass wiring. If you want to use the Softie3 relay bypass instead (sold separately) please refer to that project documentation for wiring instructions.

Note: Drill Guides are approximate and may require tweaking depending on the types of jacks, switches and pots you use.

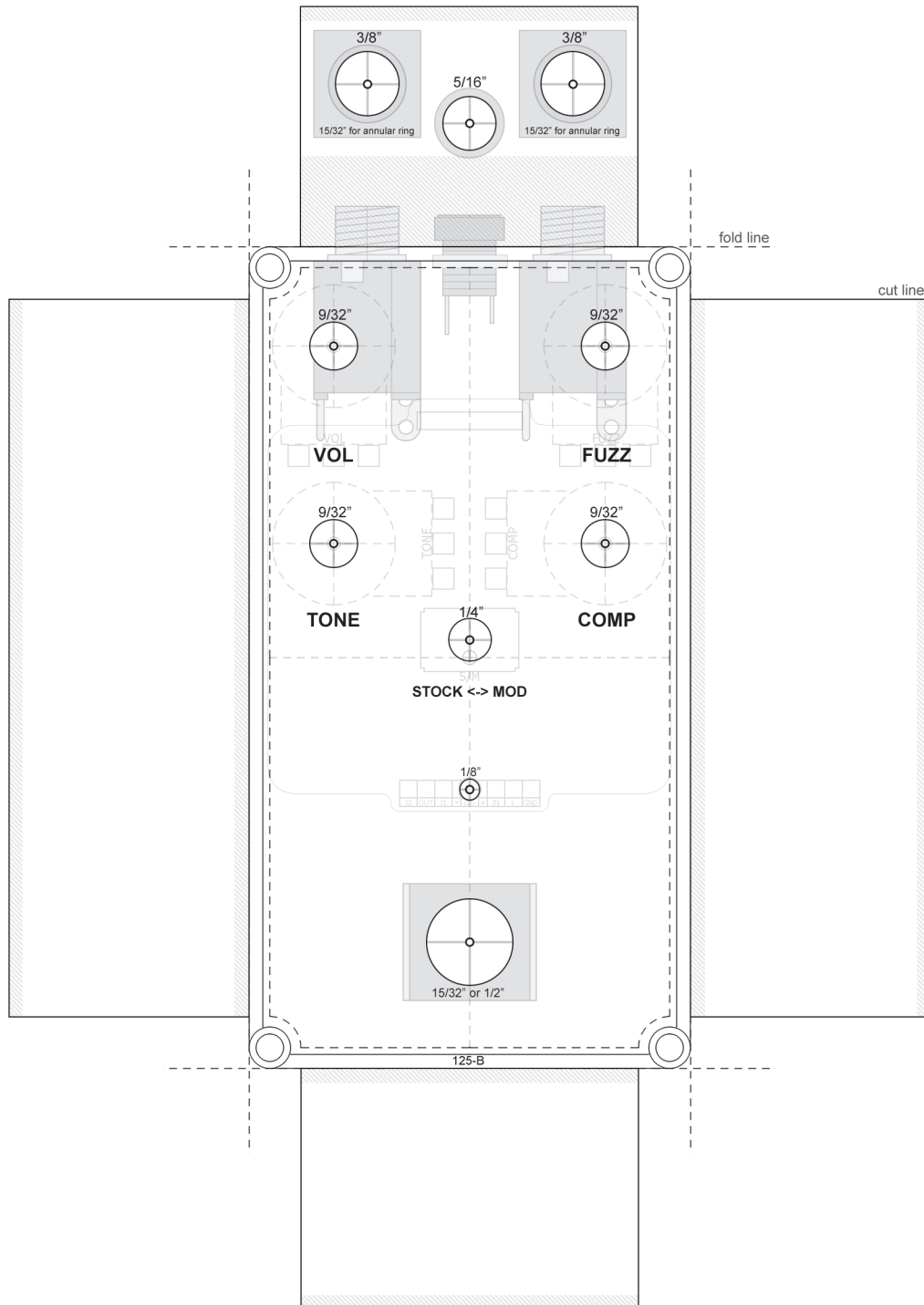

Use this drill template for regular 3PDT bypass.

Note: Drill Guides are approximate and may require tweaking depending on the types of jacks, switches and pots you use.

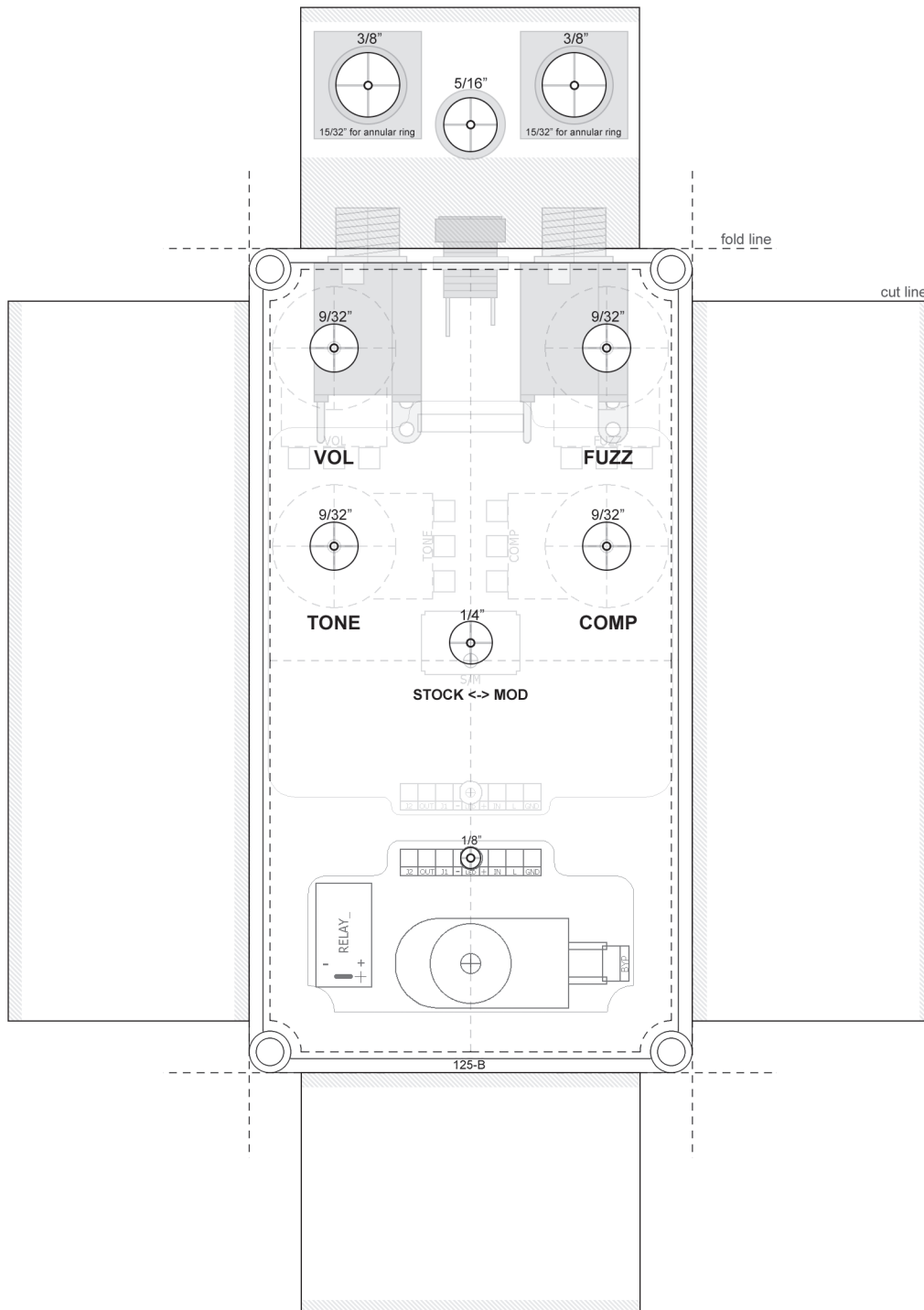

Use this drill template for Softie3 relay bypass (sold separately).

Q1	2n3904	IC1	NE5532
C	6.41	1	4.25
B	5.73	2	4.25
E	0.52	3	4.06
Q2	2n3644	4	0
C	7.46	5	4.24
B	8.22	6	4.25
E	8.97	7	4.24
Q3	2n3644	8	8.8
C	2.8		
B	7.7		
E	8.07		
Q4	2n7000		
D	4.24		
G	4.24		
S	4.46		
Q5	2n7000		
D	4.25		
G	4.25		
S	4.5		

- 9.42vDC One Spot
- Current Draw: 7mA
- Testing Condition: Vol, Fuzz, Tone @ 50%, Comp full CCW.
- Q3 Collector will change readings at higher Comp settings.

