

DEADRINGER2022

FX TYPE: Overdrive

Based on the Fulltone® FD-2™

Enclosure Size: 1590BB

"Softie" compatibility: Softie3

© 2022 [madbeanpedals](http://madbeanpedals.com)



Overview

The **Deadringer2022** could be considered either an expansion of the mbp FD-1™ **OneShot** project or an FD-2™ with mods. It is identical to the OneShot but with the boost channel of the FD-2™ added. As such, most of the information here will be a repetition of the OneShot documentation.

If you are familiar with the FD-2™, you know that the "Boost" function isn't an independent circuit but rather it increases the gain in the feedback loop of the circuit's one IC. The boost amount is in direct proportion to the clipping diodes used. IOW, the louder/less compressed the gain of the overdrive is, the louder the Boost function will be when turned on.

Obviously, this circuit is basically a TS (or SD-1, if you prefer) with a lot of extras. And, like many TS-based circuits you either like it and know how to use it (meaning on top of a little natural amp break-up) or you prefer the "transparent overdrive" approach. There's nothing wrong with either. With the "Flat Mids" mode you can get rid of some of that mid-range hump so if you are looking for that special Screamer with a solo boost, the **Deadringer2022** may fit the bill.

Controls

- **VOL, TONE, DRIVE** - Standard overdrive controls.
- **BOOST**: A secondary channel/gain setting that can be used as a solo boost when needed.
- **MID** - This trimmer allows you to dial in the Flat Mids setting. Stock is @ 3/4 up. Lower settings will reduce gain and EQ flatness. I stuck with the stock setting for my build.
- **SLM** - Three position switch that selects Silicon, LED or Mosfet clipping.
- **CFV** - Three position switch that selects between Vintage, Flat Mids or "Comp Cut" clipping modes. The Vintage and Flat modes work with all three clipping options on the SLM switch. The Comp Cut mode disables the SLM switch completely (meaning no clipping diodes are used).

Note: The four different clipping modes have different output volumes. The output increases in this order: Si, Mos, LED, "CC". You will need to adjust the VOL control when switching between the clipping modes.

Terms of Use: You are free to use purchased **Deadringer2022** circuit boards for both DIY and small commercial operations. You may not offer **Deadringer2022** PCBs for resale or as part of a "kit" in a commercial fashion. Peer to peer re-sale is fine, though.

Technical assistance for your build(s) is available via the [madbeanpedals forum](http://madbeanpedals.com/forum). Please go there rather than emailing me for assistance on builds. This is because (1) I'm not always available to respond via email in a timely and continuous manner, and (2) posting technical problems and solutions in the forum creates a record from which other members may benefit.

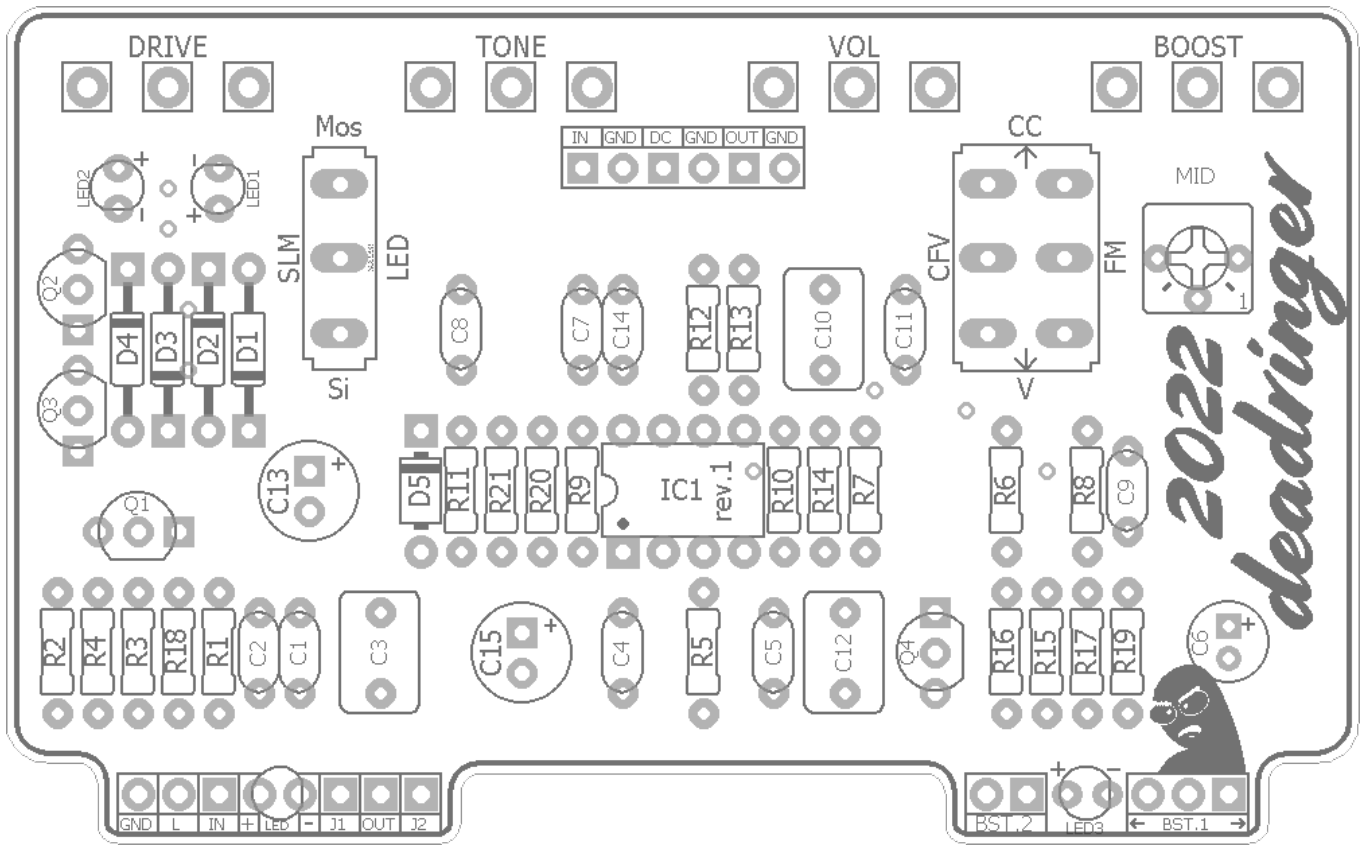

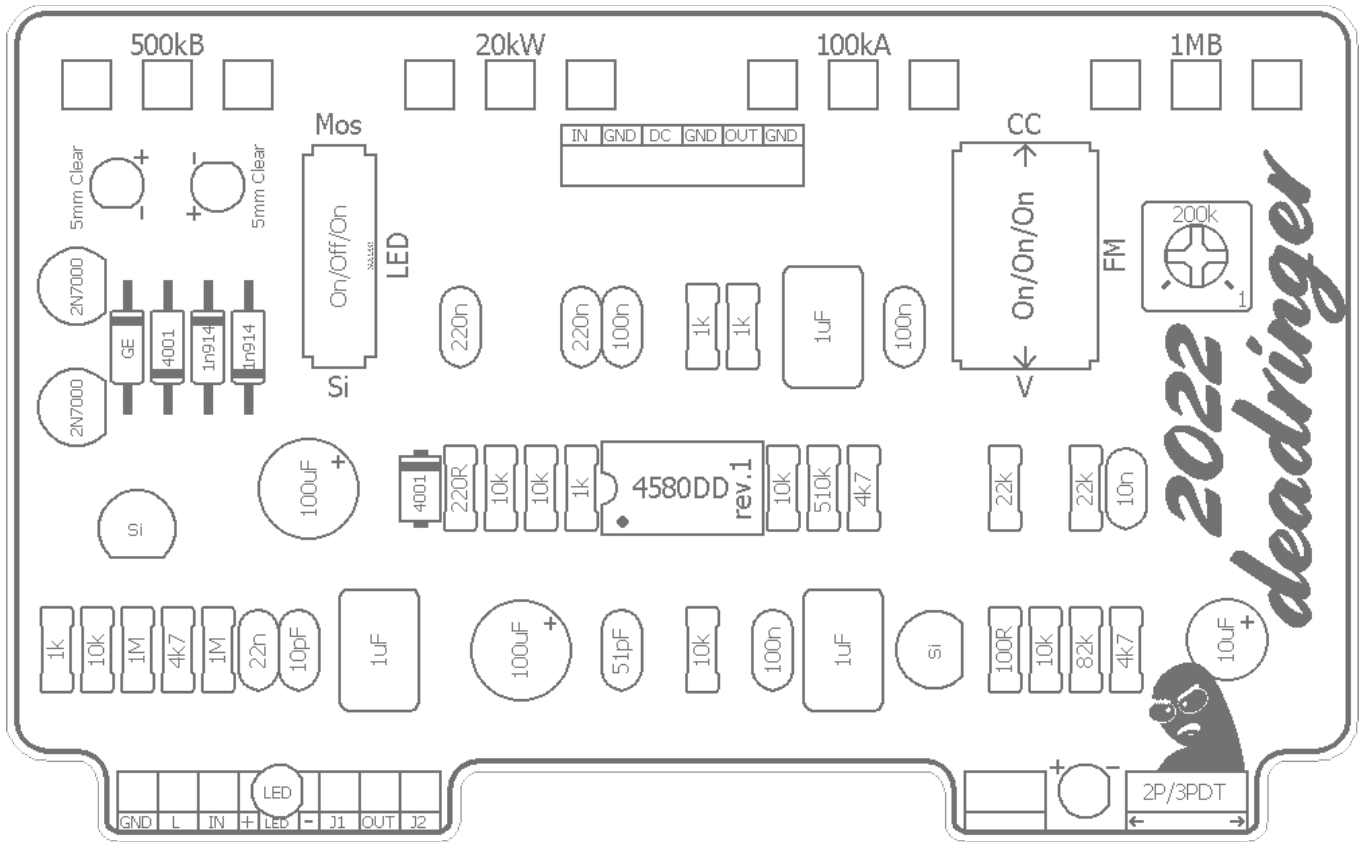

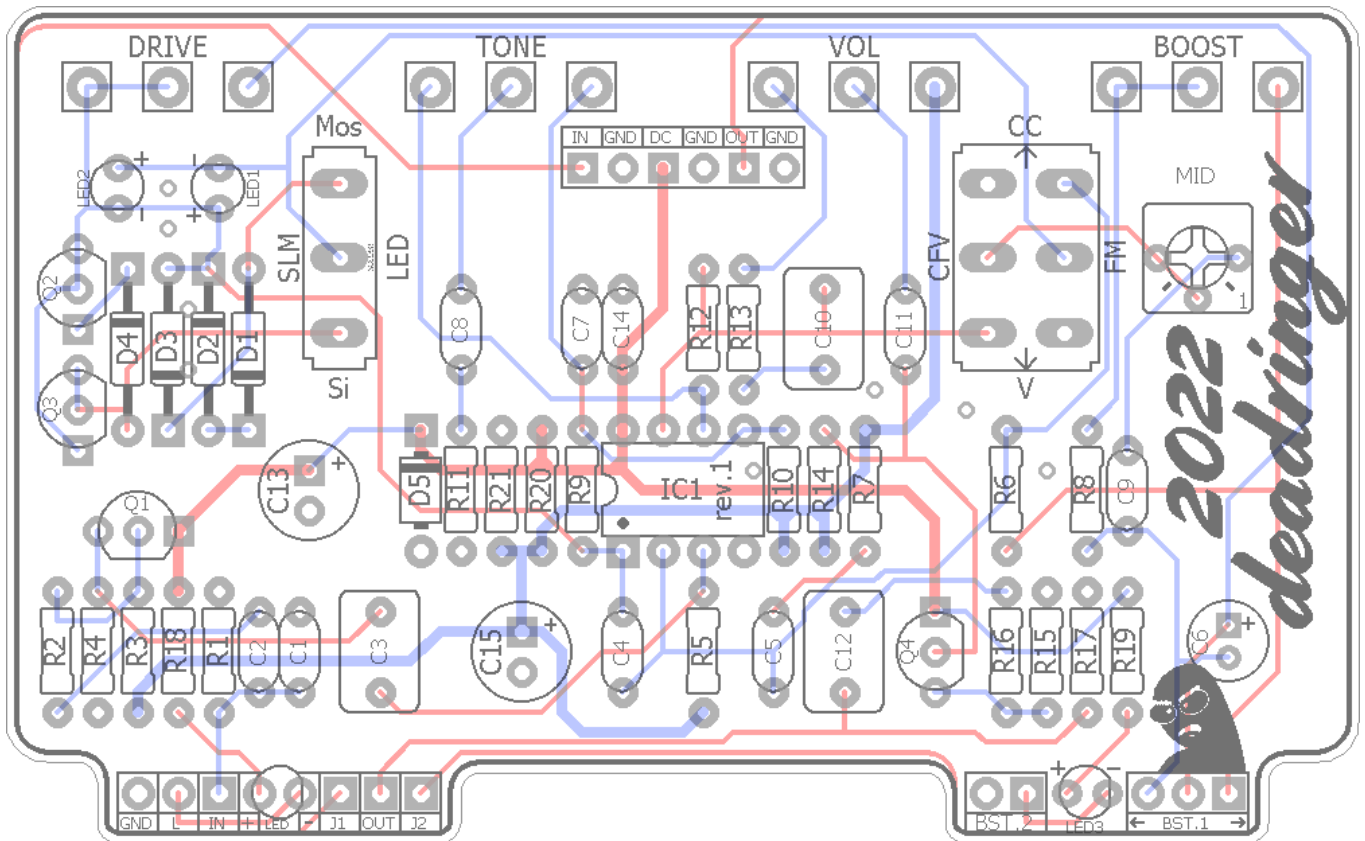

Resistors		Caps		Diodes	
R1	1M	C1	10pF	D1	1n914
R2	1k	C2	22n	D2	1n914
R3	1M	C3	1uF	D3	1n4001
R4	10k	C4	51pF	D4	1n34a
R5	10k	C5	100n	D5	1n4001
R6	22k	C6	10uF	LED1, 2	5mm Clear
R7	4k7	C7	220n	Transistors	
R8	22k	C8	220n	Q1	Si
R9	1k	C9	10n	Q2	2N7000
R10	10k	C10	1uF	Q3	2N7000
R11	220R	C11	100n	Q4	Si
R12	1k	C12	1uF	IC	
R13	1k	C13	100uF	IC1	4580DD
R14	510k	C14	100n	Switches	
R15	10k	C15	100uF	SLM	SPDT
R16	100R			CFV	DPDT
R17	82k			BST	2P or 3PDT
R18	4k7			Trimmer	
R19	4k7			MID	200k
R20	10k			Pots	
R21	10k			TONE	20kW
				VOL	100kA
				DRIVE	500kB
				BOOST	1MB

Value	QTY	Type	Rating
100R	1	Metal / Carbon Film	1/4W
220R	1	Metal / Carbon Film	1/4W
1k	4	Metal / Carbon Film	1/4W
4k7	3	Metal / Carbon Film	1/4W
10k	6	Metal / Carbon Film	1/4W
22k	2	Metal / Carbon Film	1/4W
82k	1	Metal / Carbon Film	1/4W
510k	1	Metal / Carbon Film	1/4W
1M	2	Metal / Carbon Film	1/4W
10pF	1	Ceramic / MLCC / Mica	25v min.
51pF	1	Ceramic / MLCC / Mica	25v min.
10n	1	Film	25v min.
22n	1	Film	25v min.
100n	3	Film	25v min.
220n	2	Film	25v min.
1uF	3	Film	25v min.
10uF	1	Film	25v min.
100uF	2	Electrolytic	25v min.
1n914	2		
1n4001	2		
1n34a	1	sub: BAT41	
LED	2	5mm Clear White	
Si	2	2n5088, 2n3904, etc.	
2N7000	2		
4580DD	1	or, TLC272 (suggested)	
SPDT	1	On/Off/On, PCB or Pin Mount	
DPDT	1	On/On/On, PCB or Pin Mount	
3PDT	2	*see notes	
200k	1	Bourns 3362p	
20kW	1	PCB Right Angle	16mm
100kA	1	PCB Right Angle	16mm
500kB	1	PCB Right Angle	16mm
1MB	1	PCB Right Angle	16mm

1n34a GE diode: You can sub a BAT41 Schottky for 1n34a.

1. <https://stompboxparts.com/semiconductors/1n34a-germanium-diode/>

5mm Water Clear White LED (LED1, 2):

1. <https://smallbear-electronics.mybigcommerce.com/led-t-1-3-4-5mm-water-clear-high-brightness/>
2. <https://stompboxparts.com/leds-bezels/5mm-led-waterclear/>
3. <https://www.taydaelectronics.com/leds/round-leds/5mm-leds/led-5mm-white-water-clear-ultra-bright.html>

4580DD (suggested, not required):

1. <https://www.mouser.com/ProductDetail/513-NJM4580DD>

TLC272CP (suggested, not required):

1. <https://www.mouser.com/ProductDetail/595-TLC272CP>

Bourns 3362p trimmer: 250k can be subbed for 200k. Adjust to ~150k for stock mids setting.

1. <https://www.taydaelectronics.com/potentiometer-variable-resistors/cermet-potentiometers/3362p/200k-ohm-trimmer-potentiometer-cermet-1-turn-3362-3362p.html>
2. <https://www.mouser.com/ProductDetail/652-3362P-1-204LF>

SPDT (On/Off/On):

1. <https://smallbear-electronics.mybigcommerce.com/spdt-center-off-short-lever-pc-mount/>
2. <https://stompboxparts.com/switches/spdt-toggle-switch-on-off-on-solder-lug-short-bat/>
3. <https://lovemyswitches.com/taiway-spdt-on-off-on-switch-solder-lug-short-shaft/>

DPDT (On/On/On):

1. <https://smallbear-electronics.mybigcommerce.com/toggle-switch-dpdt-on-on-on-short-lever/>
2. <https://stompboxparts.com/switches/dpdt-toggle-switch-on-on-on-solder-lug-short-bat/>
3. <https://lovemyswitches.com/taiway-dpdt-on-on-on-switch-solder-lug-short-shaft/>

16mm Right Angle Pots:

1. <http://smallbear-electronics.mybigcommerce.com/alpha-single-gang-16mm-right-angle-pc-mount/>
2. <https://stompboxparts.com/pots/16mm-potentiometer-short-pcb-leg/>

DC Jacks:

1. <https://smallbear-electronics.mybigcommerce.com/2-1-mm-all-plastic-round/>
2. <https://stompboxparts.com/power-connections/dc-power-jack-2-1mm-low-profile/>
3. <https://lovemyswitches.com/thinline-lumberg-dc-power-jack-2-1mm/>

1/4" jacks:

1. <https://smallbear-electronics.mybigcommerce.com/1-4-in-mono-nys229/>
2. <https://smallbear-electronics.mybigcommerce.com/1-4-in-mono-switchcraft-11/>
3. <https://lovemyswitches.com/1-4-mono-jack-lumberg-klbm-3/>
4. <https://lovemyswitches.com/1-4-mono-jack-neutrik-rean-nys229/>

My preferred 3PDT switch:

1. <https://lovemyswitches.com/pro-3pdt-latched-foot-switch-solder-lugs-feather-soft-click/>

Changes I made to the original (and why I prefer them via excessive explanation).

Clipping		
Part	Stock	OneShot
D1	1n4005	1n914
D2	1n34A	1n914
D3	1n4005	1n4001
D4	1n4005	1n34a or D9E
LED1, 2	none	5mm Clear
Pots		
Tone	25kB	20kW
Vol	100kB	100kA
Transistors		
Q1, Q4	2SC1815 Si (2n5088, 2n3904)	
IC		
IC1	4558	4580DD or TLC272

Clipping

Si mode: Admittedly, I did not have the 1n4005 or 1n34a on hand for this build. So, I tried 1n4001 and D9E, resp. I did not like this combo at all. The problem with germanium diodes used as soft clippers is that the upper mids are clipped really well but lower frequencies do not get clipped much less. It sounds very weird to me. Perhaps if I had the exact components it would sound better but this lines up with my experience in the past. So, I switched to all silicon, as is the case with the vintage TS/SD-1.

Mos mode: The only change here was to make D4 a germanium instead of silicon (D9E vs. 1n4005). The additional diode makes for asymmetrical clipping and the use of a germanium results in a softer, gradual turn on mode for the mosfet-as-clipper. My personal preference.

LED mode: Using a center-off switch here allows for a third clipping mode provided the *diodes used are significantly higher forward voltage*. As-is, the LEDs are always in-circuit as clippers (except for the Comp Cut mode) but when you select diode pairs that are lower in their forward voltage they clip first and ignore the LEDs altogether. I found that standard red diffused did not really work since they light up a bit in all modes. Using 5mm clear white worked perfectly. This mode is a bit more compressed than Comp Cut (no diode clipping).

Pots

For the OneShot, I picked a 1MA instead of 500kB for the Drive control. The 1MA offers a little extra OD at max, but gives a slightly wider range of soft compression at lower settings. However, given that the Deadringer has essentially two Drive controls I didn't think it necessary and stuck with the two stock values. I do not like 25kB for the tone control. It bunches up way too much around 3/4 up so the shift from treble cut to treble sounds unnatural. A 20kW solved this. The 100kA for Vol is a better choice for the myriad of clipping options as it gives finer control over the volume when you go between them.

Transistor

I changed this mostly for convenience. The 2sc1815 are center-pin collector and I just don't stock these in my library. So, I changed the transistor type to the standard CBE pinout. These transistors are used as buffers so the actual component used should not make much difference.

IC

Sure, the 4558 is great. But the 4580DD and TLC272 sound greater! One caveat: the TLC272 is limited to 16v max. **If you want to run the OneShot at 18v, then use the 4558 or 4580DD.**

Bonus clipping choice

There is an alternative clipping choice I found that works really well with this circuit. Instead of using the GE and two 2n7000, use a single BS170! I've seen this in some of the VFE circuits and Jack Orman talks a bit about it on the [Muzique site](#) (third entry). Turns out it sounds really good here.

The BS170 sits pretty much in the middle between silicon and LED clipping. And, to my ears it seems to have less "mids-focus". To use a single BS170, omit D4 and Q2. Install the BS170 in the Q3 position but turn it 180° (since the pin-out is opposite the 2n7000). Before you commit to this, it might be worth socketing D4, Q2 and Q3 to see whether you like it or not. I went with my spec'd clippers for the OneShot but used the BS170 in my Deadringer2022 build (for variety).



Footswitches

You'll need one 3PDT footswitch for the bypass. The Boost switch can be either a 3PDT or DPDT footswitch. It doesn't matter which you choose. The wiring diagram shows how to wire the Boost channel for a 3PDT. It will be exactly the same for a DPDT except there won't be a center column of lugs like you have with the 3PDT.

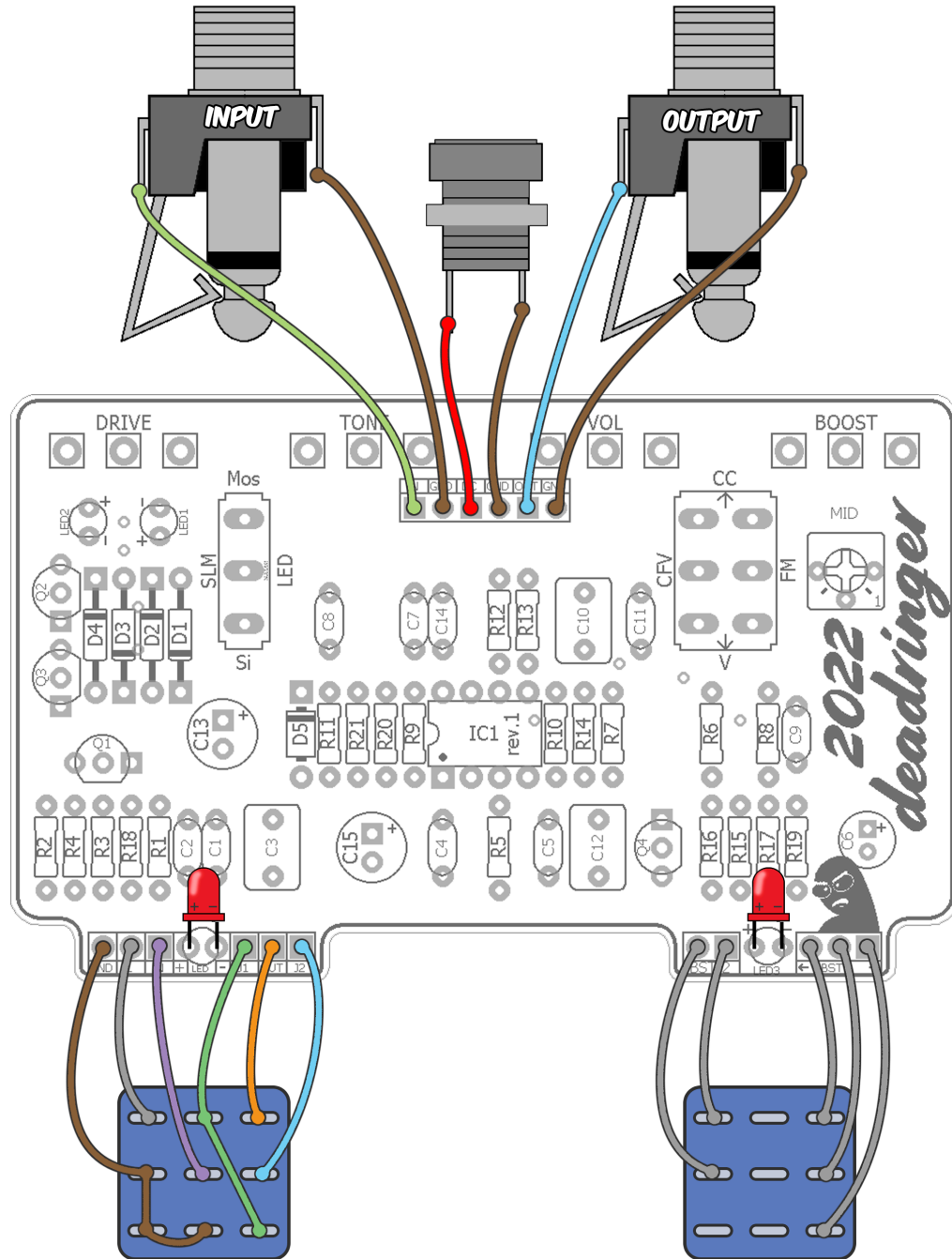

The bypass and boost LEDs are soldered directly to the PCB.

Note: Drill Guides are approximate and may require tweaking depending on the types of jacks, switches and pots you use.

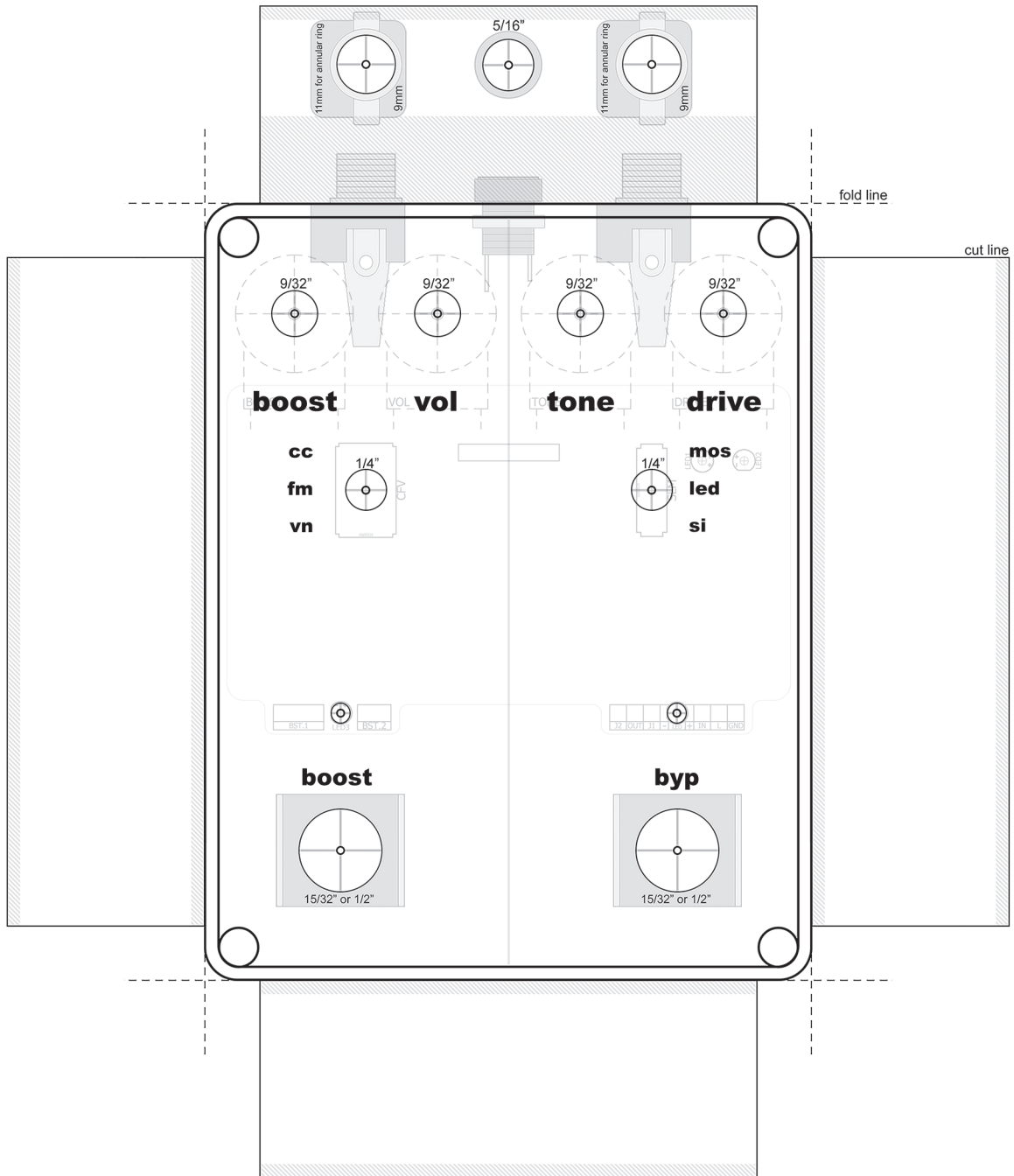

IC1	4580DD
1	4.82
2	4.77
3	4.76
4	0
5	4.81
6	4.81
7	4.81
8	9.5
Q1	Si
C	9.5
B	3.55
E	3.14
Q4	Si
C	9.5
B	3.9
E	3.43

- 9.5vDC One Spot
- Current Draw: 6mA
- Testing conditions:
Pots @ noon. Switches down.

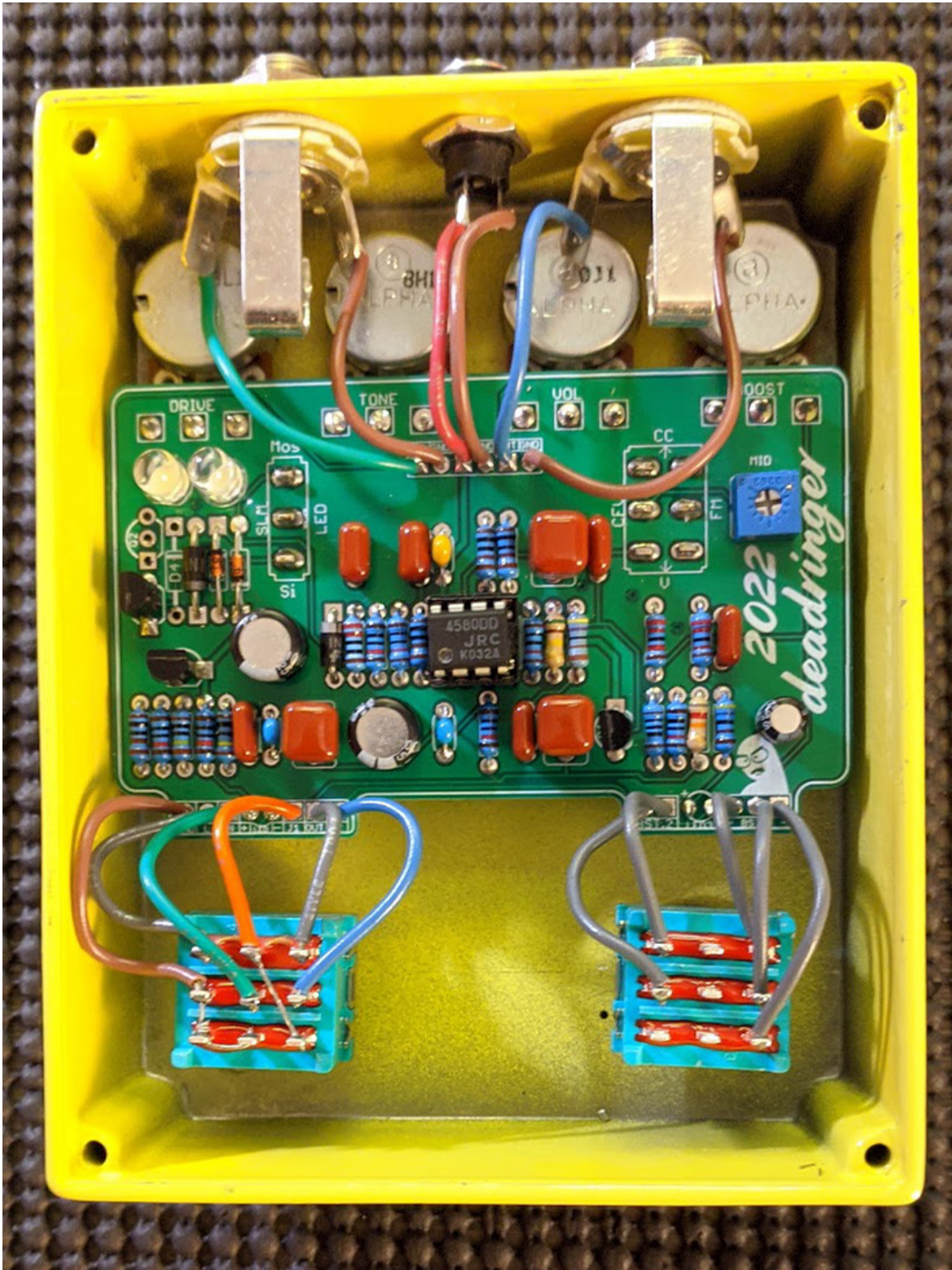

I used BC550 for the two buffers so they are flipped 180° from the footprint shown (opposite pinouts). I also used a single BS170 for the mosfet clipping.

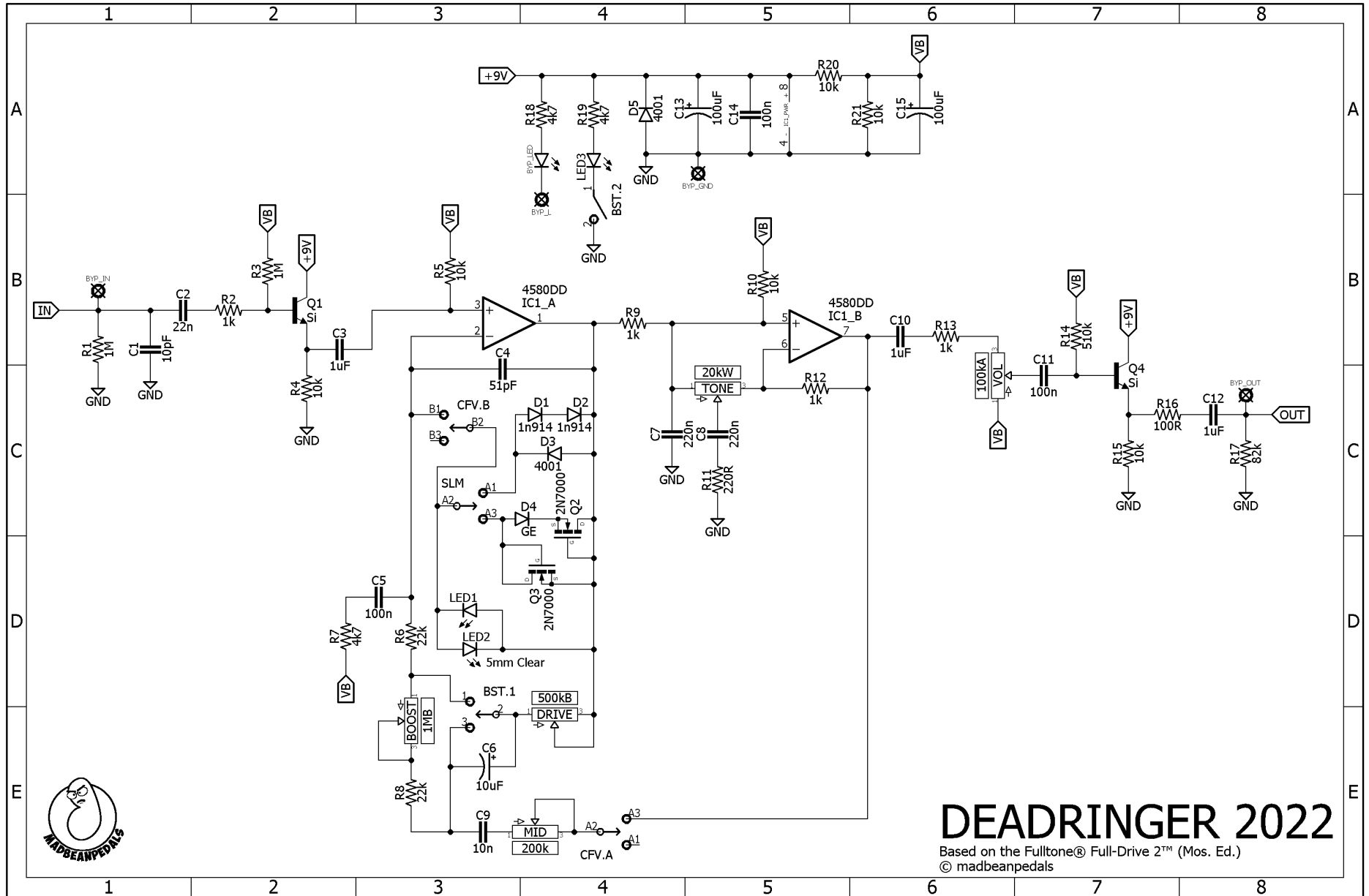

DEADRINGER 2022

Based on the Fulltone® Full-Drive 2™ (Mos. Ed.)
© madbeanpedals

