

FRAUDHACKER

FX TYPE: Fuzz Octave

Based on the Boss® BF-2™

Enclosure Size: 1590BB

"Softie" compatibility: none

© 2022 [madbeanpedals](http://madbeanpedals.com)



Overview

Having built a number of flangers over the years from the exceptional to adequate (I'm not naming names) I can say with reasonable confidence that the BF-2™ falls into the top half of the flanger bell curve. Perhaps not quite as beloved as the MXR 117 or EHX Electric Mistress, the BF-2 holds its own and is likely to satisfy many builders who need a high quality, straight-forward flanger pedal that is easy to build and relatively low cost.

The Fraudhacker is a faithful adaption of the BF-2™. The only modifications made were the removal of the Boss flip-flop bypass (in favor of true bypass), and the option of using different BBD technology depending on part availability. This flanger circuit should be accessible to most experience levels and I can recommend it as a worthy addition to your arsenal.

Controls

- **RATE** - Modulation speed.
- **MAN** - Used for manual control of the flanger in place of the LFO to set a notched frequency center. MAN is somewhat interactive with the RATE and DEPTH controls and works best when the latter are set at 50% and below.
- **DEPTH** - Modulation intensity.
- **RES** - Modulation feedback.
- **BIAS** - This trimmer sets the voltage input bias of the BBD.
- **CLOCK** - This trimmer sets the maximum operational frequency of the clock chip (it should be 50kHz for the Fraudhacker).
- **T1** - This trimmer is used to limit the amount of feedback introduced with the Res control to prevent the flanger from going into self-oscillation.

04.02.23 update: The wiring diagram has been modified. The previous fix I suggested turns out not to be needed.

Terms of Use: You are free to use purchased **Fraudhacker** circuit boards for both DIY and small commercial operations. You may not offer **Fraudhacker** PCBs for resale or as part of a "kit" in a commercial fashion. Peer to peer re-sale is fine, though.

Technical assistance for your build(s) is available via the [madbeanpedals forum](http://madbeanpedals.com). Please go there rather than emailing me for assistance on builds. This is because (1) I'm not always available to respond via email in a timely and continuous manner, and (2) posting technical problems and solutions in the forum creates a record from which other members may benefit.

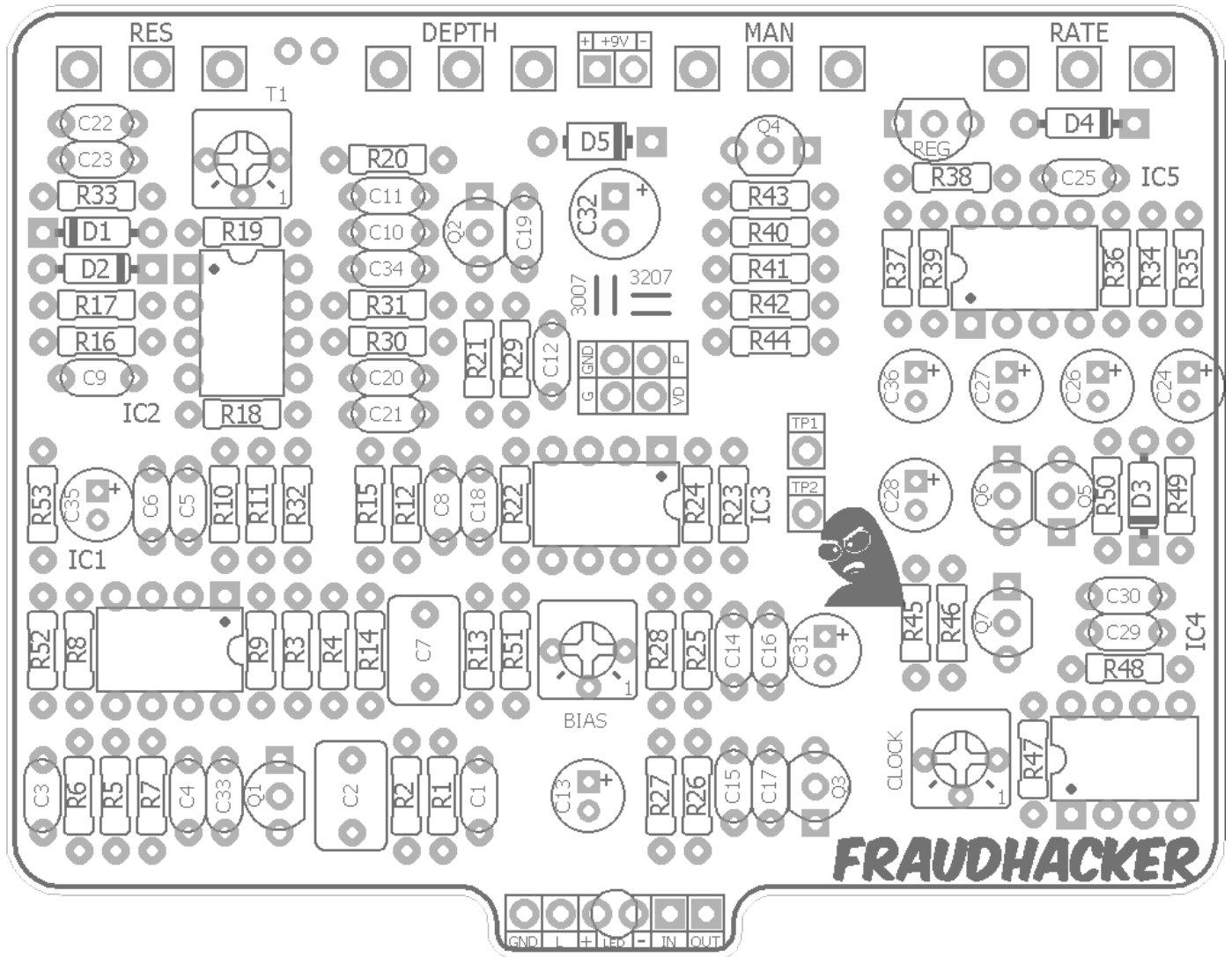

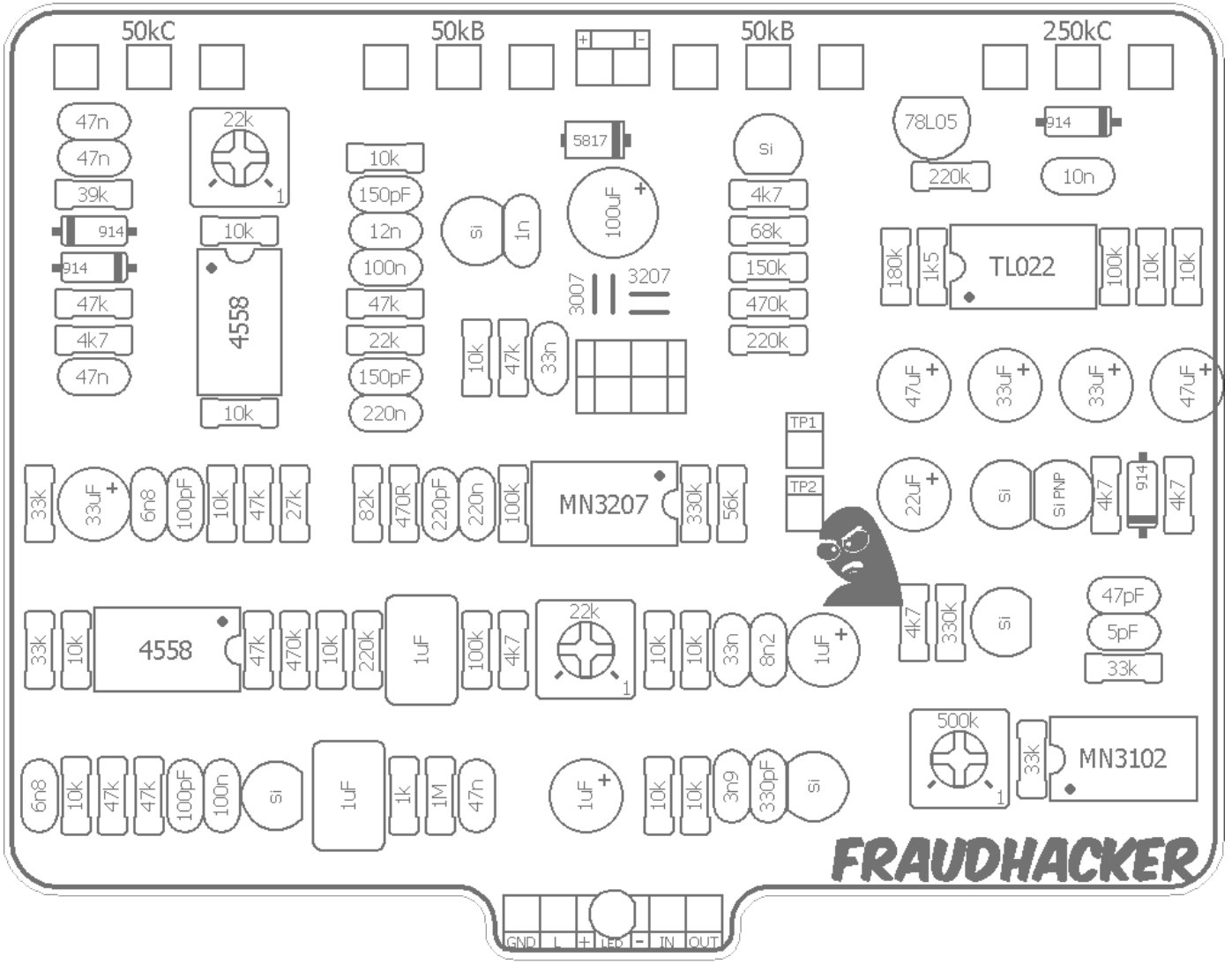

FRAUDHACKER

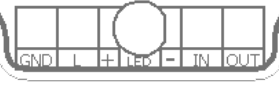

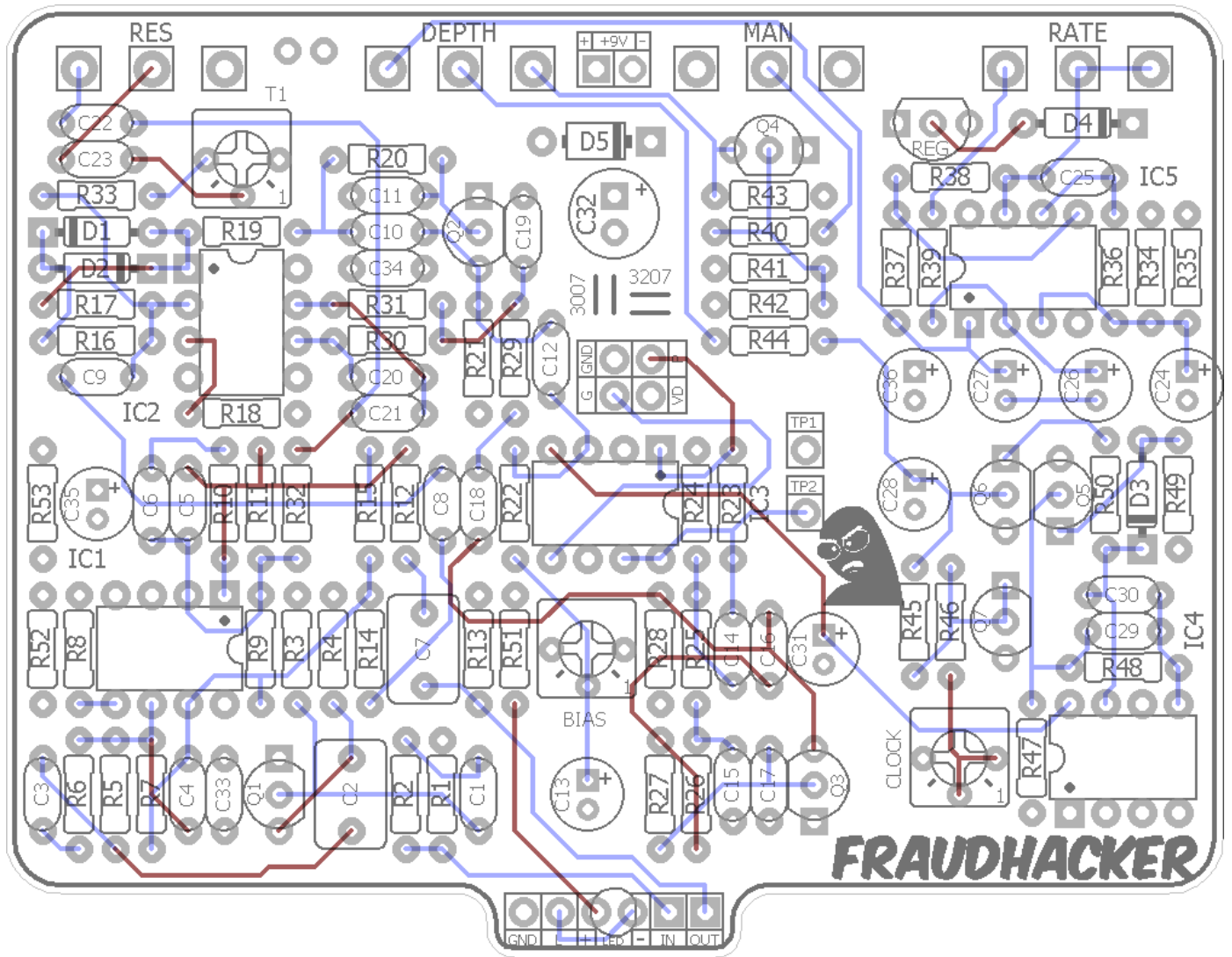

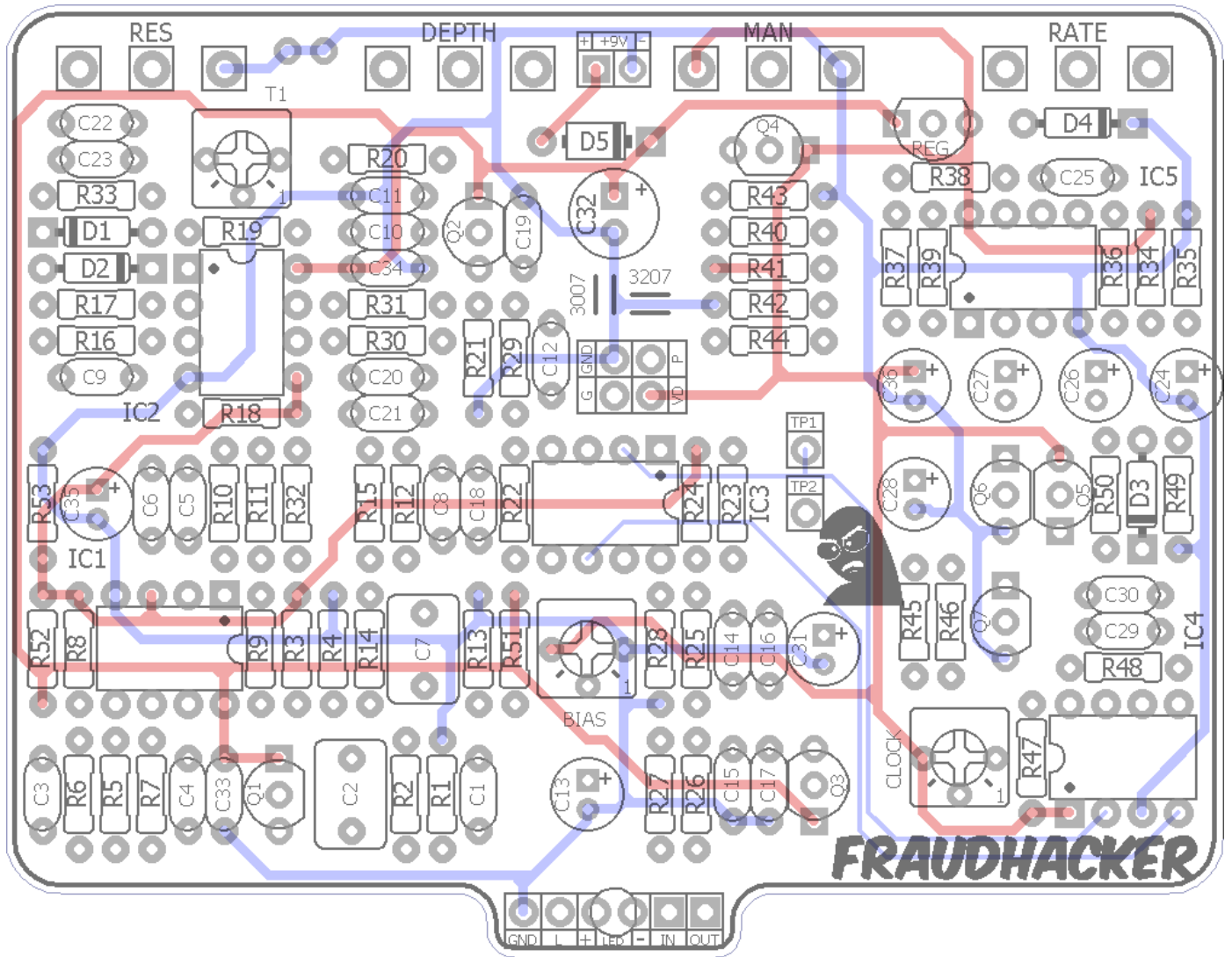

Resistors		Resistors		Caps		Caps	
R1	1M	R31	47k	C1	47n	C31	1uF
R2	1k	R32	27k	C2	1uF	C32	100uF
R3	470k	R33	39k	C3	6n8	C33	100n
R4	10k	R34	10k	C4	100pF	C34	100n
R5	47k	R35	10k	C5	100pF	C35	33uF
R6	10k	R36	100k	C6	6n8	C36	47uF
R7	47k	R37	180k	C7	1uF	Diodes	
R8	10k	R38	220k	C8	220pF	D1 - D4	1n914
R9	47k	R39	1k5	C9	47n	D5	1n5817
R10	10k	R40	68k	C10	12n	Transistors	
R11	47k	R41	150k	C11	150pF	Q1	2n5088
R12	470R	R42	470k	C12	33n	Q2	2n5088
R13	100k	R43	4k7	C13	1uF	Q3	2n5088
R14	220k	R44	220k	C14	33n	Q4	2n5088
R15	82k	R45	4k7	C15	3n9	Q5	2n5087
R16	4k7	R46	330k	C16	8n2	Q6	2n5088
R17	47k	R47	33k	C17	330pF	Q7	2n5088
R18	10k	R48	33k	C18	220n	ICs	
R19	10k	R49	4k7	C19	1n	IC1	4558
R20	10k	R50	4k7	C20	150pF	IC2	4558
R21	10k	R51	4k7	C21	220n	IC3	MN3207
R22	100k	R52	33k	C22	47n	IC4	MN3102
R23	56k	R53	33k	C23	47n	IC5	TL022
R24	330k			C24	47uF	Regulator	
R25	10k			C25	10n	REG	78L05
R26	10k			C26	33uF	Trimmers	
R27	10k			C27	33uF	BIAS	22k
R28	10k			C28	22uF	T1	22k
R29	47k			C29	5pF	CLOCK	500k
R30	22k			C30	47pF	Pots	
						DEPTH	50kB
						MAN	50kB
						RES	50kC
						RATE	250kC

Value	QTY	Type	Rating	Value	QTY	Type	Rating
470R	1	Carbon / Metal Film	1/4W	8n2	1	Film	16v min.
1k	1	Carbon / Metal Film	1/4W	10n	1	Film	16v min.
1k5	1	Carbon / Metal Film	1/4W	12n	1	Film	16v min.
4k7	6	Carbon / Metal Film	1/4W	33n	2	Film	16v min.
10k	14	Carbon / Metal Film	1/4W	47n	4	Film	16v min.
22k	1	Carbon / Metal Film	1/4W	100n	2	Film	16v min.
27k	1	Carbon / Metal Film	1/4W	220n	2	Film	16v min.
33k	4	Carbon / Metal Film	1/4W	1uF	1	Film	16v min.
39k	1	Carbon / Metal Film	1/4W	1uF	3	Electrolytic	16v min.
47k	7	Carbon / Metal Film	1/4W	22uF	1	Electrolytic	16v min.
56k	1	Carbon / Metal Film	1/4W	33uF	3	Electrolytic	16v min.
68k	1	Carbon / Metal Film	1/4W	47uF	2	Electrolytic	16v min.
82k	1	Carbon / Metal Film	1/4W	100uF	1	Electrolytic	16v min.
100k	3	Carbon / Metal Film	1/4W	1n914	4		
150k	1	Carbon / Metal Film	1/4W	1n5817	1		
180k	1	Carbon / Metal Film	1/4W	2n5088	6		
220k	3	Carbon / Metal Film	1/4W	2n5087	1		
330k	2	Carbon / Metal Film	1/4W	4558	2		
470k	2	Carbon / Metal Film	1/4W	MN3207	1		
1M	1	Carbon / Metal Film	1/4W	MN3102	1		
5pF	1	Ceramic / MLCC	16v min.	TL022	1		
47pF	1	Ceramic / MLCC	16v min.	78L05	1		
100pF	2	Ceramic / MLCC	16v min.	22k	2	Bourns 3362p	
150pF	2	Ceramic / MLCC	16v min.	500k	1	Bourns 3362p	
220pF	1	Ceramic / MLCC	16v min.	50kB	2	PCB Right Angle	16mm
330pF	1	Ceramic / MLCC	16v min.	50kC	1	PCB Right Angle	16mm
1n	1	Film	16v min.	250kC	1	PCB Right Angle	16mm
3n9	1	Film	16v min.				
6n8	2	Film	16v min.				

MN3207/MN3102:<https://cabintechglobal.com/mn3207><https://cabintechglobal.com/mn3102>

Some people have had good luck with the Cabintech MN32xx supply and some have not. I bought two sets. Both worked. YMMV.

v3207/v3102:

These seem out of stock in most places. They may be available directly from CoolAudio but they do not appear to sell in quantities less than 10.

MN3007:<https://cabintechglobal.com/mn3007><https://smallbear-electronics.mybigcommerce.com/ic-mn3007-xvive-audio-re-makes/>

Using an MN3007 requires an MN3101. The MN3102 cannot be used.

TL022:<https://stompboxparts.com/semiconductors/tl022cp-dual-op-amp-ic/><https://www.taydaelectronics.com/tl022cp-tl022-operational-amplifier-ic.html>**Bourns 500k trimmer:**<https://stompboxparts.com/pots/trim-pot-3362p/><https://www.taydaelectronics.com/potentiometer-variable-resistors/cermet-potentiometers/3362p/500k-ohm-trimmer-potentiometer-cermet-1-turn-3362-3362p.html>**Bourns 22k Trimmer**<https://stompboxparts.com/pots/trim-pot-3362p/><https://www.taydaelectronics.com/potentiometer-variable-resistors/cermet-potentiometers/3362p/20k-ohm-trimmer-potentiometer-cermet-1-turn-3362p.html>

- 20k and 25k can be subbed for 22k without issue.

16mm Right Angle Pots:<http://smallbear-electronics.mybigcommerce.com/alpha-single-gang-16mm-right-angle-pc-mount/>**DC Jacks:**<https://smallbear-electronics.mybigcommerce.com/2-1-mm-all-plastic-round/><https://stompboxparts.com/power-connections/dc-power-jack-2-1mm-low-profile/><https://lovemyswitches.com/thinline-lumberg-dc-power-jack-2-1mm/>**1/4" jacks:**<https://smallbear-electronics.mybigcommerce.com/1-4-in-mono-nys229/><https://smallbear-electronics.mybigcommerce.com/1-4-in-mono-switchcraft-11/><https://lovemyswitches.com/1-4-mono-jack-lumberg-klbm-3/><https://lovemyswitches.com/1-4-mono-jack-neutrik-rean-nys229/>**My preferred 3PDT switch:**<https://lovemyswitches.com/pro-3pdt-latched-foot-switch-solder-lugs-feather-soft-click/>

Due to a manufacturing error, the bypass LED needs a small workaround in order to function properly. At issue is when the cathode of the LED is soldered directly to the PCB (as normal) the LED remains dimly lit when “off”. In order to make the LED go fully dark in bypass, you’ll need to omit the hookup spot on the PCB and wire the cathode directly to the 3PDT switch. This eliminates the problem. This should only be an issue for this first batch of boards. I will be switching to another manufacturer for subsequent runs. [See the wiring diagram for more.](#)

I’ve included the option to use either MN/v3207, MN/v3102 **or** MN3007/MN3101 for the BBD and clock chips. Since this effect only runs at 9v, there really is no reason to use the MN3007/MN3101. However, we continue to be in a supply chain vacuum so the 3207 and 3102 may not be easily available. There are two jumper wires you need to solder in on the PCB according to which technology you use.

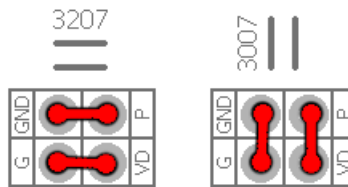

You can mix and match the MN and “v” (Cool Audio) brands of the 3207 and 3102 but if you use an MN3007 BBD you *must* also use an MN3101 clocking chip. The MN3102 will not work properly with an MN3007.

Calibration

Luckily, calibrating the Fraudhacker is very easy. Here’s what you need to do:

1. Set all controls full CCW and all trimmers halfway up.
2. If you have an audio probe, connect the probe to the “TP2” pad on the PCB (TP2 is connected to pins 7&8 of IC3). Using some audio input to the circuit adjust the Bias trimmer until you achieve the cleanest sounding output possible at TP2. If you do not have an audio probe, just listen to the effect output instead of using TP2 and adjust the Bias trimmer for a similar result.
3. If you have a frequency measurement setting on your multimeter, connect the black lead to ground and the red lead to the “TP1” pad on the PCB (TP1 is connected to pin2 of IC3). Adjust the clock trimmer until you get a reading of 50kHz. If you do not have a frequency measurement tool, leave the Clock trimmer at about half up. BTW: you do not need any audio input for this step.
4. Now you can start to adjust all the controls to verify that they are working correctly. Check slow and fast Rates, different Depth, Manual and Res settings for function.
5. The final step is to set T1. This limits the amount of feedback created by the Res control. In the absence of T1, the circuit will go into self-oscillation when the Res control is at max. We will use T1 to prevent that.
6. Use the following settings: Rate 1/3 up, Depth and Res full up, Man full CCW.
7. Using audio input to the circuit adjust T1 so that the max Res setting cuts off just before self-oscillation. If you are adventurous, you can set T1 so that there is *just a hint* of oscillation when the Res control is maxed. This can sound cool. You just have to be careful since it can get really loud really quick if you don’t control it.

Mods

You may wonder if one uses the MN3007/MN3101 chipsets then can the Fraudhacker run at higher voltages? And the answer is yes but with a caveat. I have tested the circuit with 12v power and it works fine. However, you'll notice that in this circuit the BBD supply voltage is *limited to the regulator output* which is about 5.6v stock. So, running it at 12v does nothing for the BBD itself. However, you can try substituting a higher voltage regulator in place of the 5v one (socketing REG is a good idea here). I tested it using a 6v regulator with the circuit running at 12v and it worked fine. You may even be able to go up to a 9v regulator but I did not test that. Most likely you'll need to re-adjust the clock trimmer if you make any of these changes.

Your next question might be: can I just ditch the regulator altogether with the MN3007 and make everything run at 12v? The answer is no, you cannot. It turns out that the regulator prevents LFO ticking in this circuit. So, it's necessary. And, honestly: this circuit sounds just fine stock. I don't see any big advantage in pushing the supply a couple extra volts. But, someone will end up asking these questions so luckily I've already done the work to try to answer them!

Lastly, and because you may not already be confused enough, I did test running the circuit @ 9v with MN3207/MN3102 but using a 6v regulator instead of 5v and that also worked just fine.

FINAL NOTE:

On the schematic I listed the transistors as "Si" without a specific designation. I used both 2n5088 and 2n5087 for the NPN and PNP parts, resp. Other pin compatible transistors might work depending on what you have available. I believe 2n3904 and 2n3906 would work well as subs if needed but I did not test any transistor types other than the 5088/5087.

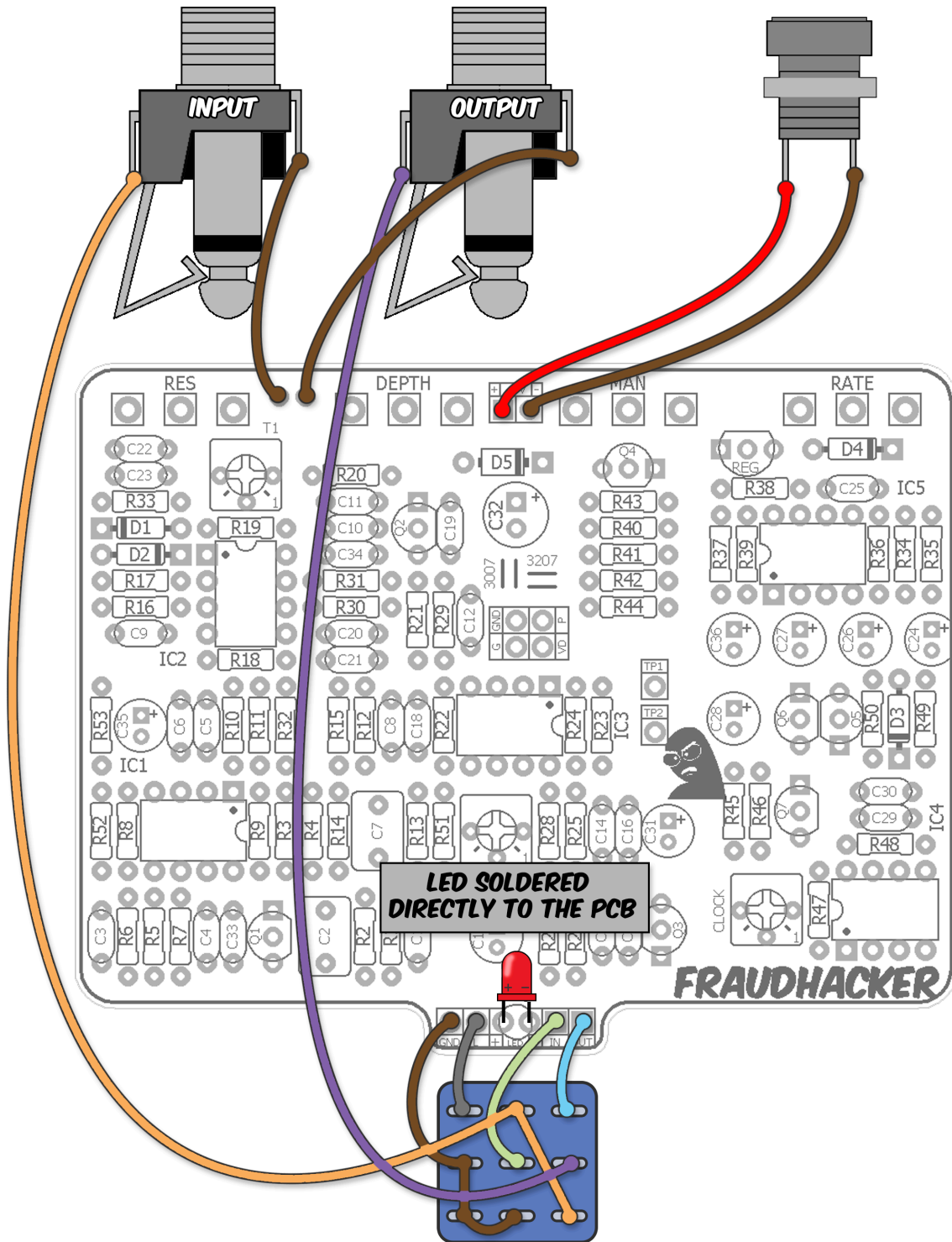

04.02.23 update: in the previous version of this doc I advised not to use the “L” pad to wire the LED cathode to the 3PDT and instead use a wire directly from the LED. You do not need to do this. It turns out I had a problem with the specific LED I used in my build (from a cheap batch I bought). You can solder the LED to the PCB as normal and use the wiring diagram above.

Note: Drill Guides are approximate and may require tweaking depending on the types of jacks, switches and pots you use.

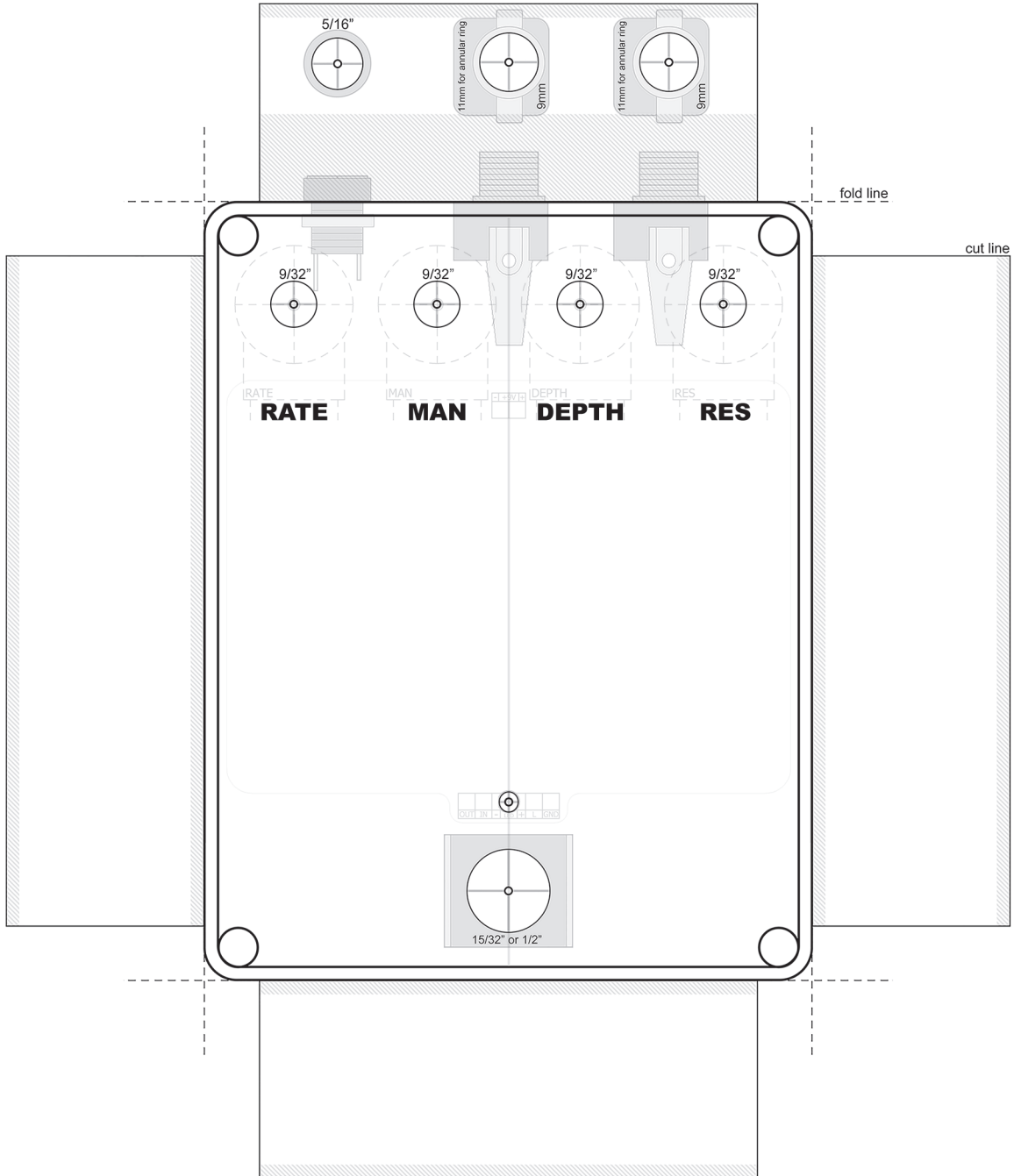

IC1	4558	IC5	TL022
1	4.54	1	varies
2	4.53	2	2.83
3	4.53	3	2.83
4	0	4	0
5	4.53	5	varies
6	4.54	6	varies
7	4.55	7	varies
8	9.24	8	5.67
IC2	4558	Q1	2n5088
1	4.54	C	9.24
2	4.52	B	3.96
3	4.49	E	3.51
Q2	2n5088		
4	0	C	9.24
5	4.53	B	4.52
6	4.53	E	3.94
Q3	2n5088		
7	4.59	C	9.24
8	9.24	B	3.95
IC3	MN3207		
1	0	E	3.46
2	2.75	Q4	2n5088
3	2.87	C	5.67
4	5.29	B	1.59
5	5.97	E	1.03
6	2.77	Q5	2n5087
7	3.18	C	208mV
8	3.18	B	5.55
IC4	MN3102		
1	5.67	E	5.67
2	2.75	Q6	2n5088
3	0	C	4.2
4	2.77	B	517mV
5	5.52	E	0
6	155mV	Q7	2n5088
7	4.56	C	498mV
8	5.29	B	498mV
		E	0
REG	78L05		
		I	9.24
		G	0.63
		O	5.67

- 9.42vDC One Spot
- Current Draw: ~15mA
- All knobs set CCW

