

GLASSHOLE_REV1

FX TYPE: Phaser

Based on the Musitronics® Mutron Phasor II™

Enclosure Size: 1590BB

"Softie" compatibility: none

© 2022 [madbeanpedals](http://madbeanpedals.com)



Rev.1 changes: Some of the original top mounted wiring has been removed to eliminate an LFO ticking issue and the wiring diagram has been updated. A few resistors changed locations accordingly. C3 has been changed to 100n from 15pF. This was an error I made in misunderstanding the band pass filtering at IC1 and was pointed out to me by a fellow DIY'er. You will still need to perform the Q1 fix addressed on the last page. Not other changes were made for rev.1.

Overview

The Mutron Phasor II™ is simply a fantastic effect. I've built plenty of phasers over the years, and optically-based ones tend to be my favorites. There's just something extra special in them that I don't quite hear in OTA or FET-based phasers. And, the Mutron is about as far as you can go optically. Actually, it isn't because I added extra phase stages to it for this project. IOW, the Glasshole is now as far as you can go optically! I await being proved wrong.

This project is based heavily on forum member bangerang101's [original project](#) (and incorporates his mods) released many years ago on the mbp forum. I added my own etchable version of his project on the forum, built it, then put it aside for a long time. A couple of years later, I built another version that incorporated tap tempo with the Electric Druid TAPLFO2 controller (as a personal project). Again, I put it aside.

Coming back to the Phasor II in 2020, I decided it would be fun to make an "extended" version that was a combo of both the previous versions I built and release it as an official project. So, the Glasshole was created. It adds two extra phase stages and a rotary selector that let's you choose between 2, 4, 6 or 8 phase stages. It also has an optional tap tempo input which interfaces with the mbp Wavelord tremolo and Tappy standalone TAPLFO3 controller.

Controls

- **RATE:** LFO speed from slow to fast.
- **DEPTH:** Intensity of the phaser effect.
- **FDBK:** Phaser feedback (the amount of feedback is 1:1 with the number of phase stages selected with the STEPS switch). So, 2 stages of phase is two stages of feedback, and so on.
- **STEPS:** This rotary switch chooses between 2, 4, 6 or 8 phase stages.
- **T1:** This trimmer sets the depth of the D2 LED. See Notes.
- **T2:** This trimmer sets the brightness of the D2 LED. See Notes.
- **TAP:** This (optional) jack allows the Glasshole to accept tap input from either the mbp Wavelord or standalone Tappy control (both feature the Electric Druid TAPLFO3 chip).

Mutron Phasor II: <http://www.effectsdatabase.com/model/musitronics/mutron/phasor/2>

Terms of Use: You are free to use purchased *Glasshole_rev1* circuit boards for both DIY and small commercial operations. You may not offer *Glasshole_rev1* PCBs for resale or as part of a "kit" in a commercial fashion. Peer to peer re-sale is fine, though.

Technical assistance for your build(s) is available via the [madbeanpedals forum](http://madbeanpedals.com). Please go there rather than emailing me for assistance on [builds](#). This is because (1) I'm not always available to respond via email in a timely and continuous manner, and (2) posting technical problems and solutions in the forum creates a record from which other members may benefit.

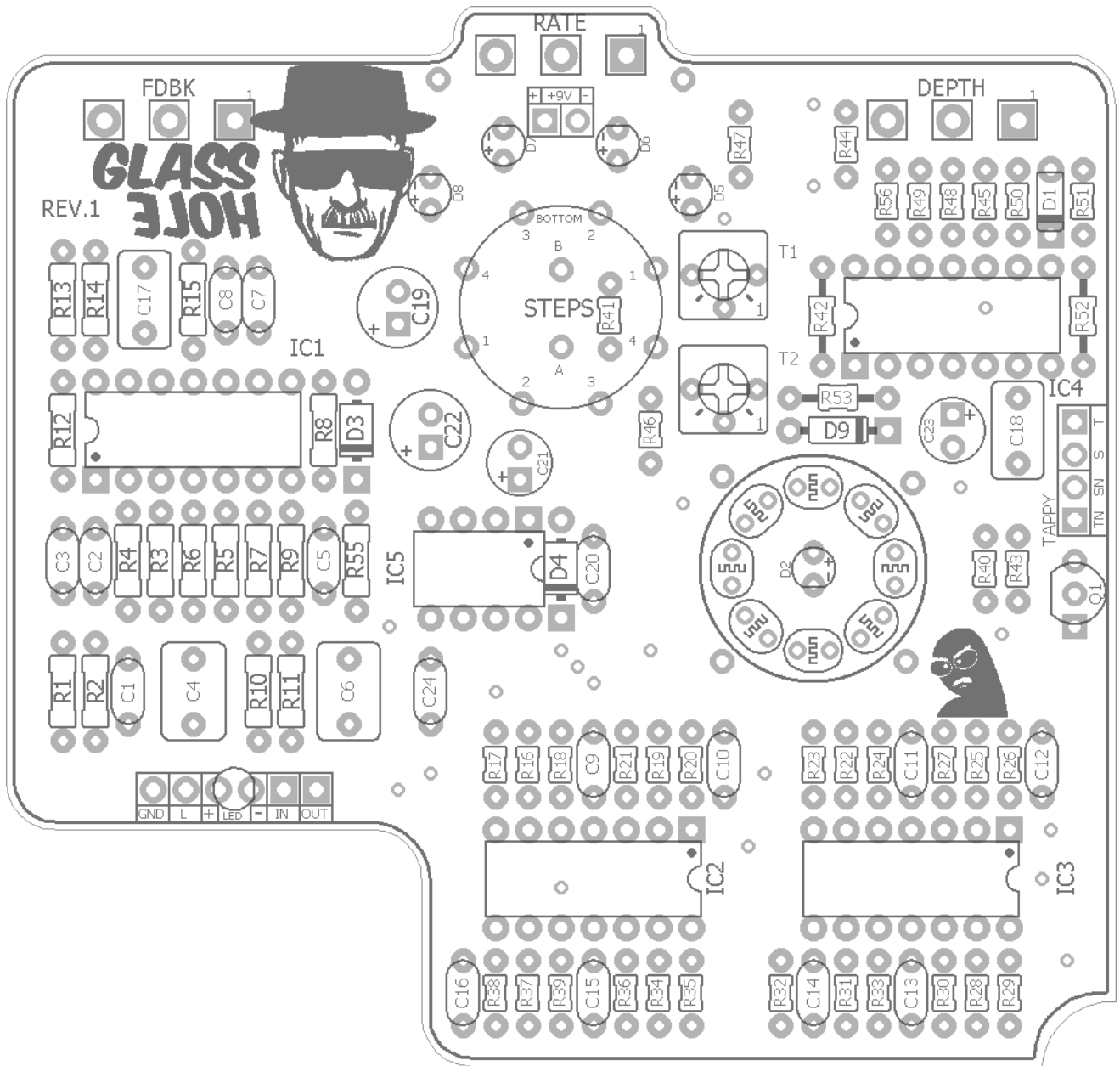

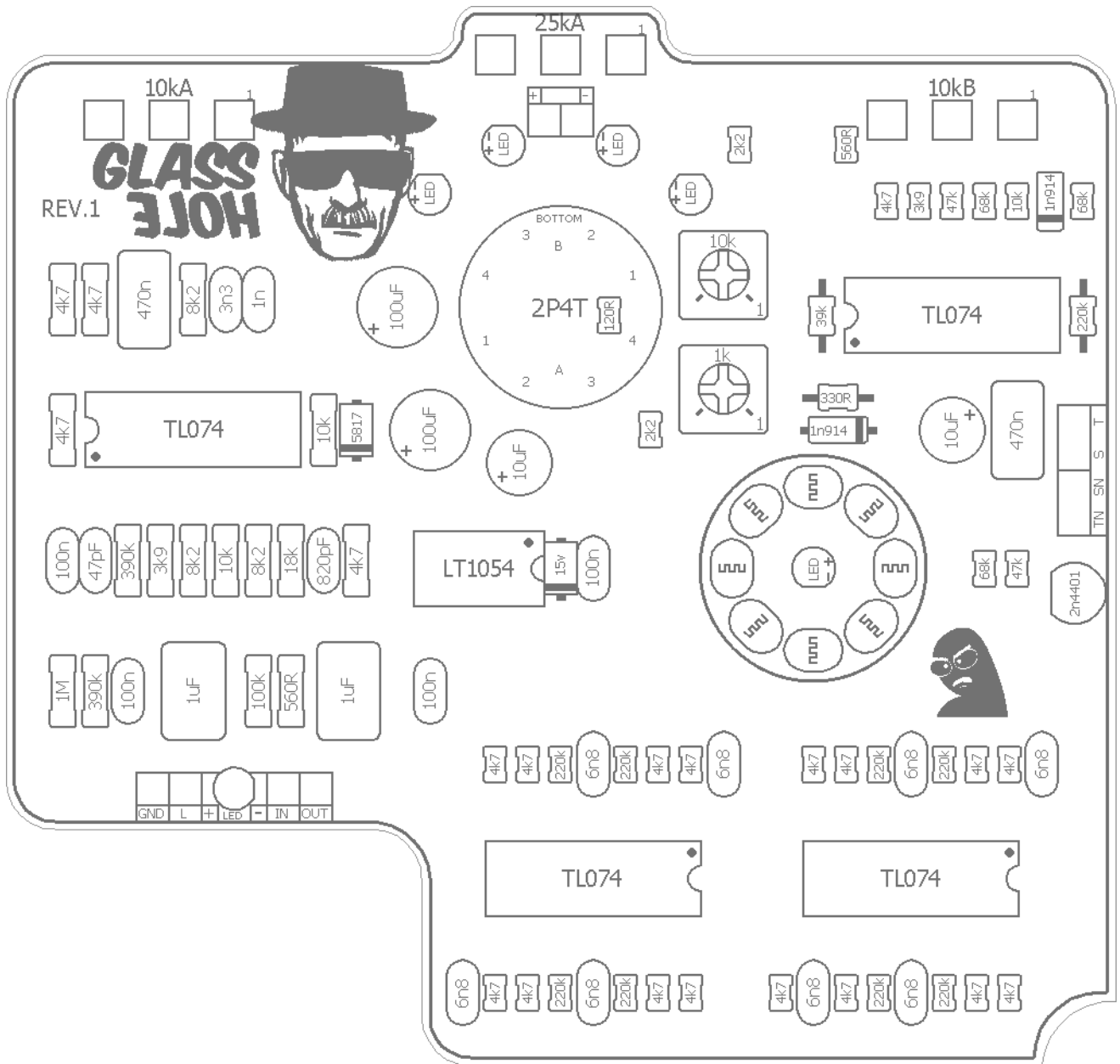

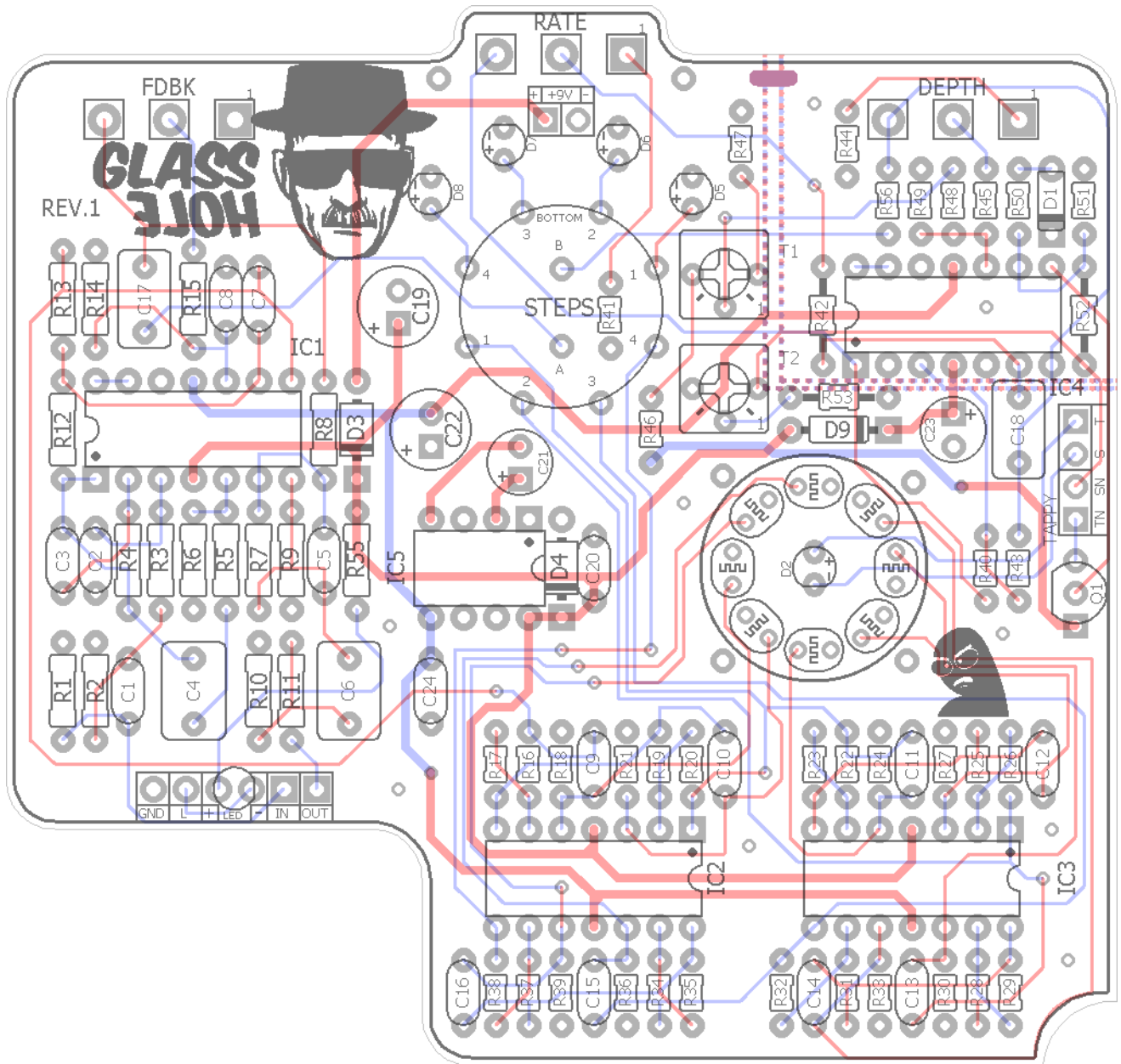

Resistors		Resistors		Caps		Diodes	
R1	1M	R29	4k7	C1	100n	D1	1n914
R2	390k	R30	220k	C2	47pF	D2	LED
R3	3k9	R31	4k7	C3	100n	D3	1N5817
R4	390k	R32	4k7	C4	1uF	D4	15v
R5	10k	R33	220k	C5	820pF	D5 - D8	LED
R6	8k2	R34	4k7	C6	1uF	D9	1n914
R7	8k2	R35	4k7	C7	1n	Transistors	
R8	10k	R36	220k	C8	3n3	Q1	2n4401
R9	18k	R37	4k7	C9	6n8	ICs	
R10	100k	R38	4k7	C10	6n8	IC1 - 4	TL074
R11	560R	R39	220k	C11	6n8	IC5	LT1054
R12	4k7	R40	68k	C12	6n8	LDR	
R13	4k7	R41	120R	C13	6n8	LDR1 - 8	9203
R14	4k7	R42	39k	C14	6n8	Jack	
R15	8k2	R43	47k	C15	6n8	TAPPY Mono (sw)	
R16	4k7	R44	560R	C16	6n8	Switch	
R17	4k7	R45	68k	C17	470n	STEPS	2P4T
R18	220k	R46	2k2	C18	470n	Trimmers	
R19	4k7	R47	2k2	C19	100uF	T1	10k
R20	4k7	R48	47k	C20	100n	T2	1k
R21	220k	R49	3k9	C21	10uF	Pots	
R22	4k7	R50	10k	C22	100uF	FDBK	10kA
R23	4k7	R51	68k	C23	10uF	DEPTH	10kB
R24	220k	R52	220k	C24	100n	RATE	25kA
R25	4k7	R53	330R				
R26	4k7	R55	4k7				
R27	220k	R56	4k7				
R28	4k7						

Value	QTY	Type	Rating	Value	QTY	Type	Rating
120R	1	Metal / Carbon Film	1/8W	1n914	2		
330R	1	Metal / Carbon Film	1/8W	LED	1	Yellow, Diffused	
560R	1	Metal / Carbon Film	1/8W	1N5817	1		
2k2	2	Metal / Carbon Film	1/8W	15v	1	Zener	
3k9	1	Metal / Carbon Film	1/8W	LED	4	Any color, Diffused	
4k7	17	Metal / Carbon Film	1/8W	2n4401	1		
10k	1	Metal / Carbon Film	1/8W	TL074	4		
39k	1	Metal / Carbon Film	1/8W	LT1054	1		
47k	2	Metal / Carbon Film	1/8W	9203	8		
68k	3	Metal / Carbon Film	1/8W	Jack	1	Switched Mono	1/8"
220k	9	Metal / Carbon Film	1/8W	2P4T	1	Mini	
560R	1	Metal / Carbon Film	1/4W	10k	1	Bourns 3362p	
3k9	1	Metal / Carbon Film	1/4W	1k	1	Bourns 3362p	
4k7	4	Metal / Carbon Film	1/4W	10kA	1	PCB Right Angle	16mm
8k2	3	Metal / Carbon Film	1/4W	10kB	1	PCB Right Angle	16mm
10k	2	Metal / Carbon Film	1/4W	25kA	1	PCB Right Angle	16mm
18k	1	Metal / Carbon Film	1/4W				
100k	1	Metal / Carbon Film	1/4W				
390k	2	Metal / Carbon Film	1/4W				
1M	1	Metal / Carbon Film	1/4W				
47pF	1	Ceramic / MLCC	25v min.				
820pF	1	Ceramic / MLCC	25v min.				
1n	1	Film	25v min.				
3n3	1	Film	25v min.				
6n8	8	Film	25v min.				
100n	4	Film	25v min.				
470n	2	Film	25v min.				
1uF	2	Film	25v min.				
10uF	2	Electrolytic	25v min.				
100uF	2	Electrolytic	25v min.				

- You can use 1/4W for all the resistors listed as 1/8W but they will need to stand on end to fit in the 5mm spacing.
- D5-D8 are optional LEDs. The TAPPY jack is also optional. Please see Notes for details.
- See Notes for an explanation of the D2 LED color.

15v Zener:

<https://www.mouser.com/ProductDetail/512-1N4744A>

You can sub 12v: <http://smallbear-electronics.mybigcommerce.com/diode-zener-1n4742a/>

2N4401:

<http://smallbear-electronics.mybigcommerce.com/transistor-2n4401/>

LT1054:

<http://smallbear-electronics.mybigcommerce.com/ic-lt1054cp/>

9203 photocell:

<http://smallbear-electronics.mybigcommerce.com/photocells-cds-5mm-diameter/>

Mono jack (optional):

<http://smallbear-electronics.mybigcommerce.com/1-8-mono-pc-mount/>

2P4T:

<http://smallbear-electronics.mybigcommerce.com/rotary-switch-miniature-2p4t/>

3362p 1k:

<https://www.mouser.com/ProductDetail/652-3362P-1-102LF>

<https://www.taydaelectronics.com/potentiometer-variable-resistors/cermet-potentiometers/3362p/1k-ohm-trimmer-potentiometer-cermet-1-turn-3362p.html>

3362p 10k:

<https://www.mouser.com/ProductDetail/652-3362P-1-103LF>

<https://www.taydaelectronics.com/potentiometer-variable-resistors/cermet-potentiometers/3362p/10k-ohm-trimmer-potentiometer-cermet-1-turn-3362p.html>

16mm Right Angle Pots (10kA, 10kB, 25kA):

<http://smallbear-electronics.mybigcommerce.com/alpha-single-gang-16mm-right-angle-pc-mount/>

Thinline DC Jack:

<http://smallbear-electronics.mybigcommerce.com/dc-power-jack-all-plastic-unswitched-2-1-mm/>

Enclosed Mono:

<http://smallbear-electronics.mybigcommerce.com/1-4-in-mono-enclosed-jack/>

<http://smallbear-electronics.mybigcommerce.com/1-4-in-mono-enclosed-switchcraft-111x/>

Lumberg Mono:

<http://smallbear-electronics.mybigcommerce.com/lumberg-1-4-compact-shrouded-mono-jack/>

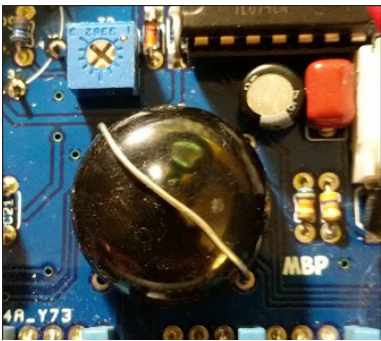
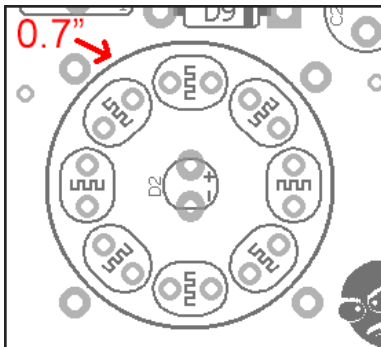
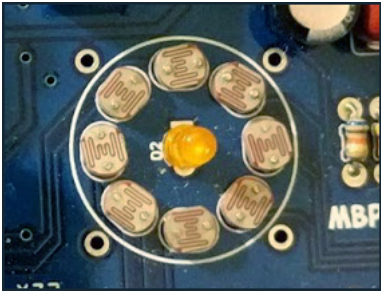

The LDRs should be soldered flat to the surface of the PCB. They will operate primarily from reflected light from the light shield you are going to make.

The purpose of the light shield is to block extraneous light from reaching the LDRs so that the only illumination they receive is from D2. It does not need to be fancy. I've made the area large enough so that one of the Alpha pot dust covers will fit over it (since they are translucent use some tape on the outside to block light). I had a couple of the old Guitar PCB "pot condoms" which actually worked perfectly here.

You'll want to secure your light shield so it stays in place, but I would wait to do that as the last step before screwing the lid on. Leave it as a loose fit while testing so you can pull it off if you want to observe how the D2 led is behaving.

To secure your shield, simply solder one end of a bit of buss wire or leftover resistor lead to one of the four mounting pads, fold it over and solder the other end to the opposite pad. Criss-cross two pieces of wire for more security.

D2 LED

I've done some experimentation with LED colors in phasers and found that their performance can be improved slightly with the right choice. I typically use red diffused LEDs in most 9203 applications but in phasers I found that some colors actually gave a little more depth. According to the datasheet info I was able to find, the 9203 photocell has an operational wavelength of 520nm. Red (diffused) LEDs typically output at 600nm and above. So, if you want to get picky use an LED that operates as close to that spec'd wavelength as possible. Out of my personal batch, yellow and orange were a closer match than red and I ended up using an orange one.

The effect will work no matter what color you stick in there. This info is more for the super detailed builder who might want to experiment with different LEDs to find the perfect match.

Calibration

- T1 sets the swing from light to dark on D2. CCW is full depth and it gets more shallow as you go clockwise.
- T2 sets the maximum brightness. CCW is full brightness and the LED will dim as you turn it clockwise.

While I could write many words on calibration it's much easier to just do it. Set your Depth at max, Rate about halfway and adjust trimmers to taste to get the best phase sweep you can. Now test those settings at the slowest and fastest Rate settings. Tweak the trimmers to taste to get the best response possible over the full range of the Rate knob. Do all this with your light shield covering the LDRs! Tip: The 1st half of T1 tends to be way too much and actually makes the phaser sweep sound doubled up (or maybe 'ghosted' is a better word).

For my build, I set both trimmers halfway. Feel free to use that as a starting point.

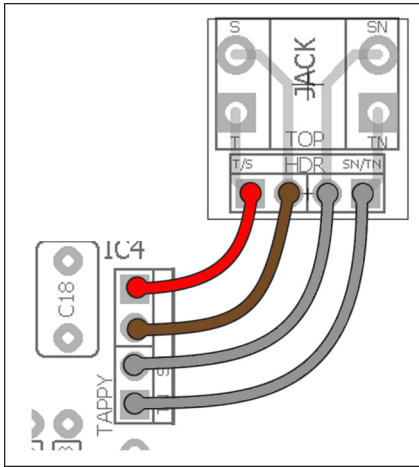

The Glasshole can accept tap tempo input from either the mbp Wavelord tremolo (assuming you built the Wavelord with the tap out option) or the mbp Tappy controller. Both use the TAPLFO3 chip and feature 16 unique waveforms, tap tempo and plenty of wave tweaking capabilities.

To use this feature on the Glasshole use the 1/8" isolated mono switching jack linked in the Shopping List. You can wire straight to the jack or use one of the miniJack breakout boards from mbp (under the Breadbuddies category in the mbp store). The wiring above shows how to connect the Glasshole to the miniJack board (note the miniJack "TOP" label for orientation) but it's the same if wiring directly to the jack pins without the breakout board.

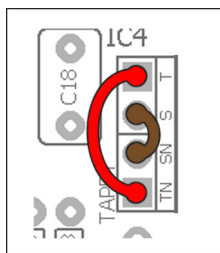

The TT input works by using the jack to disconnect the D2 led from the Glasshole LFO when a 1/8" plug is inserted . This allows D2 to be driven by the TAPLFO3 chip.

If you do not wish to use tap tempo, bypass the tap tempo input altogether. Simply wire in two jumpers on the Glasshole PCB as shown.

To connect the Glasshole to either the Wavelord or Tappy controller, you'll need a 1/8" mono or stereo cable. Mono is preferred but they can sometimes be harder to find. Stereo is actually okay. The only thing that will happen is that the S/SN connections will go to the ring of a stereo jack instead of the sleeve. Because we are using isolated 1/8" jacks, this is not a problem.

Either of these should work fine. They are stereo but a good choice since they are right angle.
https://www.amazon.com/gp/product/B01N2MY88J/ref=ox_sc_act_title_2?smid=AZPTD9CVXK9G9&psc=1
https://www.amazon.com/gp/product/B072TYZ89H/ref=ox_sc_act_title_1?smid=A69X5KMJHM850&psc=1

When the tap tempo input is used, the Rate and Depth control will become inactive on the Glasshole. The Fdbk and Steps controls will work as normal.

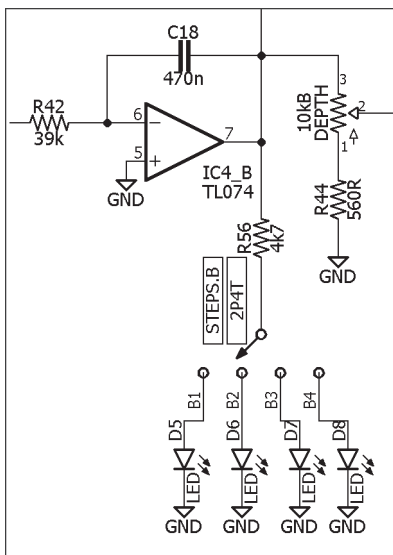

The Glasshole also has 4 LEDs (D5-D8) which light up through the different phase stages with the Steps switch. Each LED blinks in time with the internal Glasshole LFO as a tempo indicator. The LEDs are pure aesthetics and do not change the operation of the effect.

Caveat: They do not sync to tap tempo input, only the Glasshole LFO. So, if you are using the tap tempo option you might want to omit them. To omit, simply do not solder in D5-D8 nor R56. And, be sure NOT to accidentally drill for them on your enclosure!

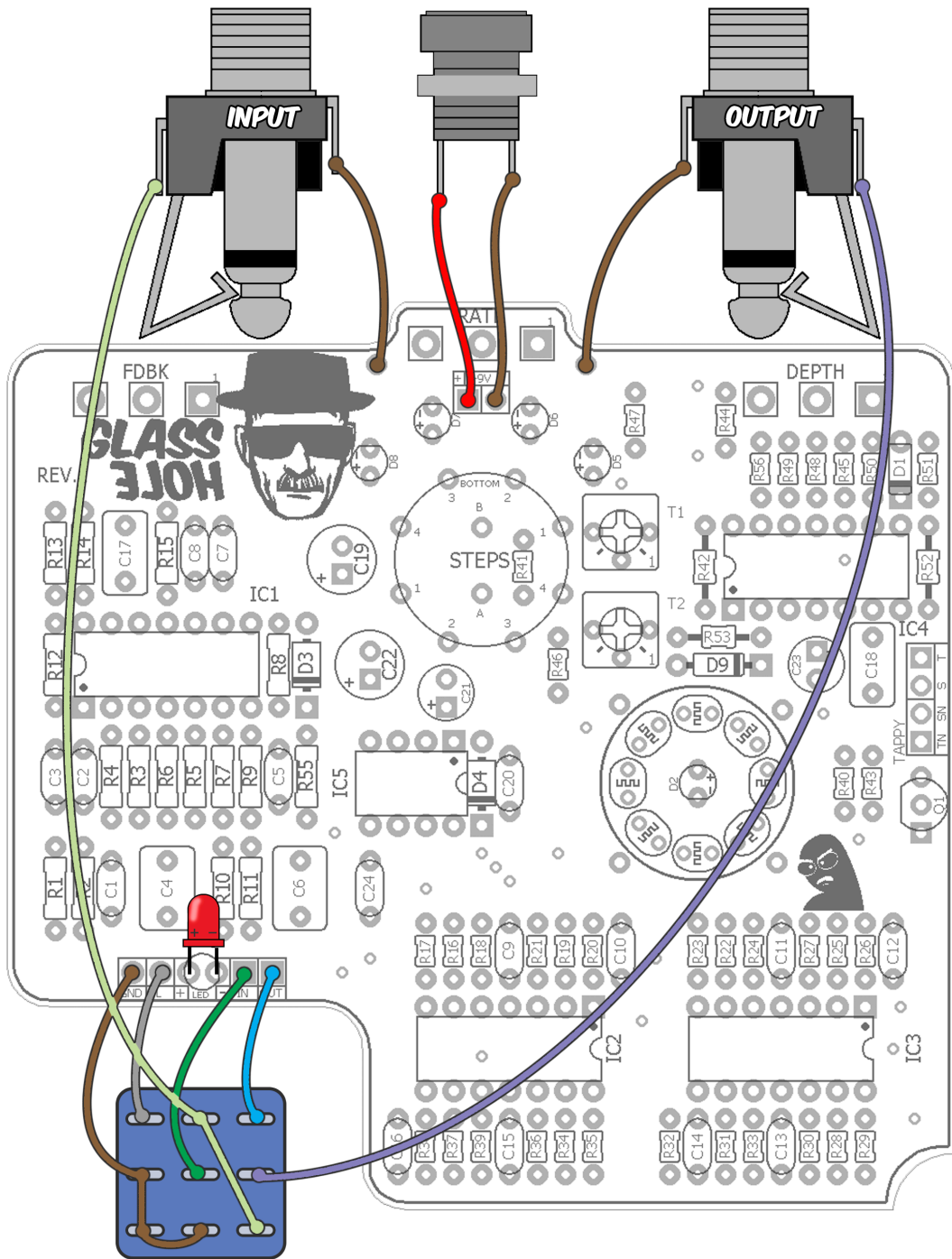

Note: Drill Guides are approximate and may require tweaking depending on the types of jacks, switches and pots you use.

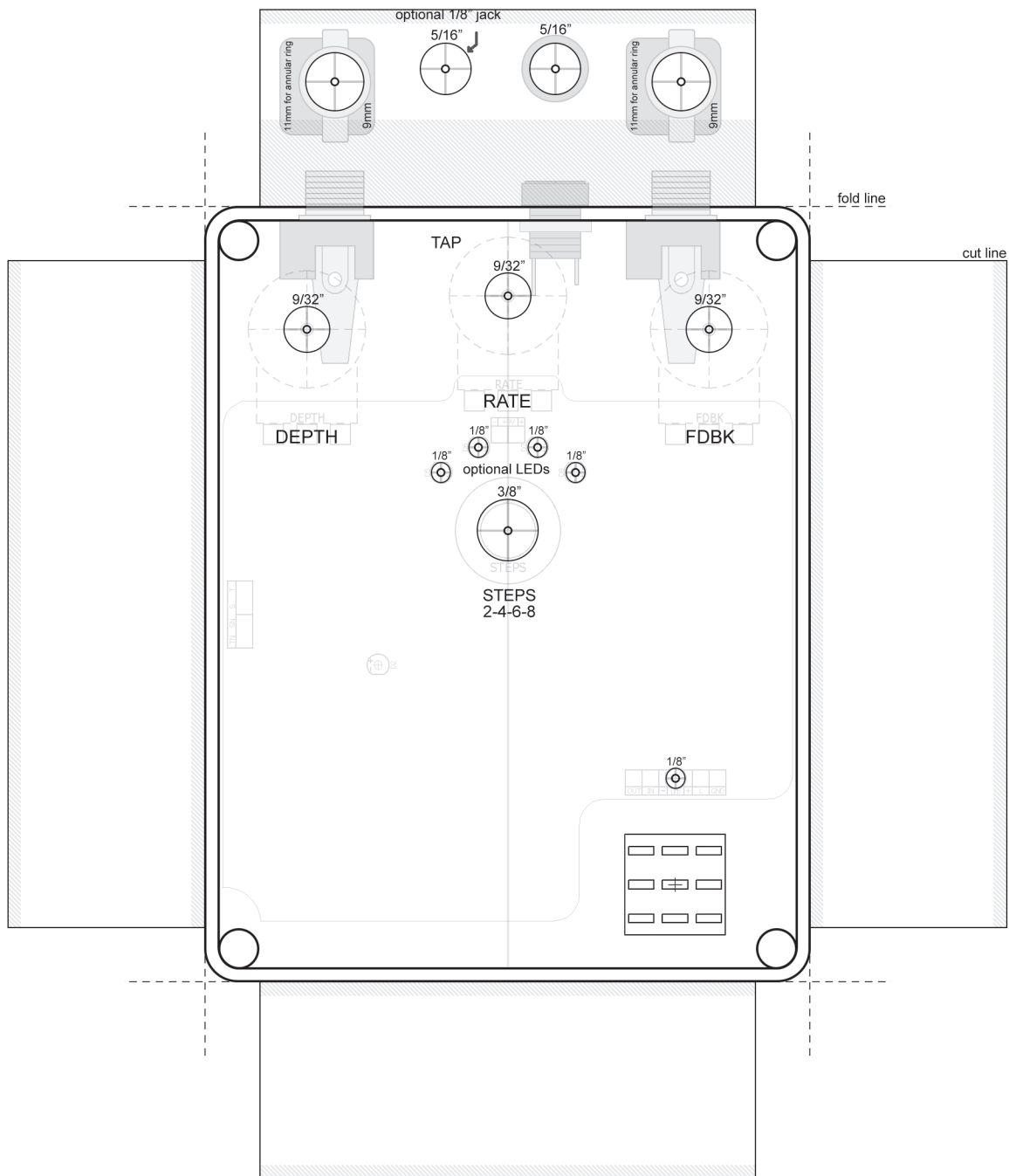

- The Glasshole does not easily accommodate the mbp Softie switching system. It may be possible to use the 125B board and simply mount it underneath the Glasshole PCB but this is pretty tedious. I recommend using a 3PDT instead.
- Might be obvious but: **Only drill for the “optional LEDs” if you intend to use them!**

IC1	TL074	IC2	TL074	IC3	TL074	IC4	TL074
1	0	1	10mV	1	0	1	varies
2	0	2	0	2	0	2	0
3	0	3	0	3	0	3	varies
4	9.1	4	9.1	4	9.1	4	8.38
5	0	5	0	5	0	5	0
6	0	6	0	6	0	6	0
7	0	7	0	7	-10mV	7	varies
8	0	8	0	8	0	8	varies
9	0	9	0	9	0	9	varies
10	0	10	0	10	0	10	varies
11	-8.2	11	-8.2	11	-8.2	11	-8.2
12	0	12	0	12	0	12	0
13	0	13	0	13	0	13	0
14	0	14	0	14	0	14	0
IC5	LT1054	Q1	2N4401				
1	1.61	C	8.38				
2	4.85	B	varies				
3	0	E	varies				
4	-3.79						
5	-8.2						
6	2.56						
7	1.43						
8	9.1						

- 9.42vDC One Spot
- Current Draw ~ 75mA
- Real-world readings on some pins may be slightly above or below 0v. I've marked anything below 10mV and above -10mV as 0 on the chart.
- Current draw is high with charge pump. Using TL064 instead of 74 may reduce it somewhat.

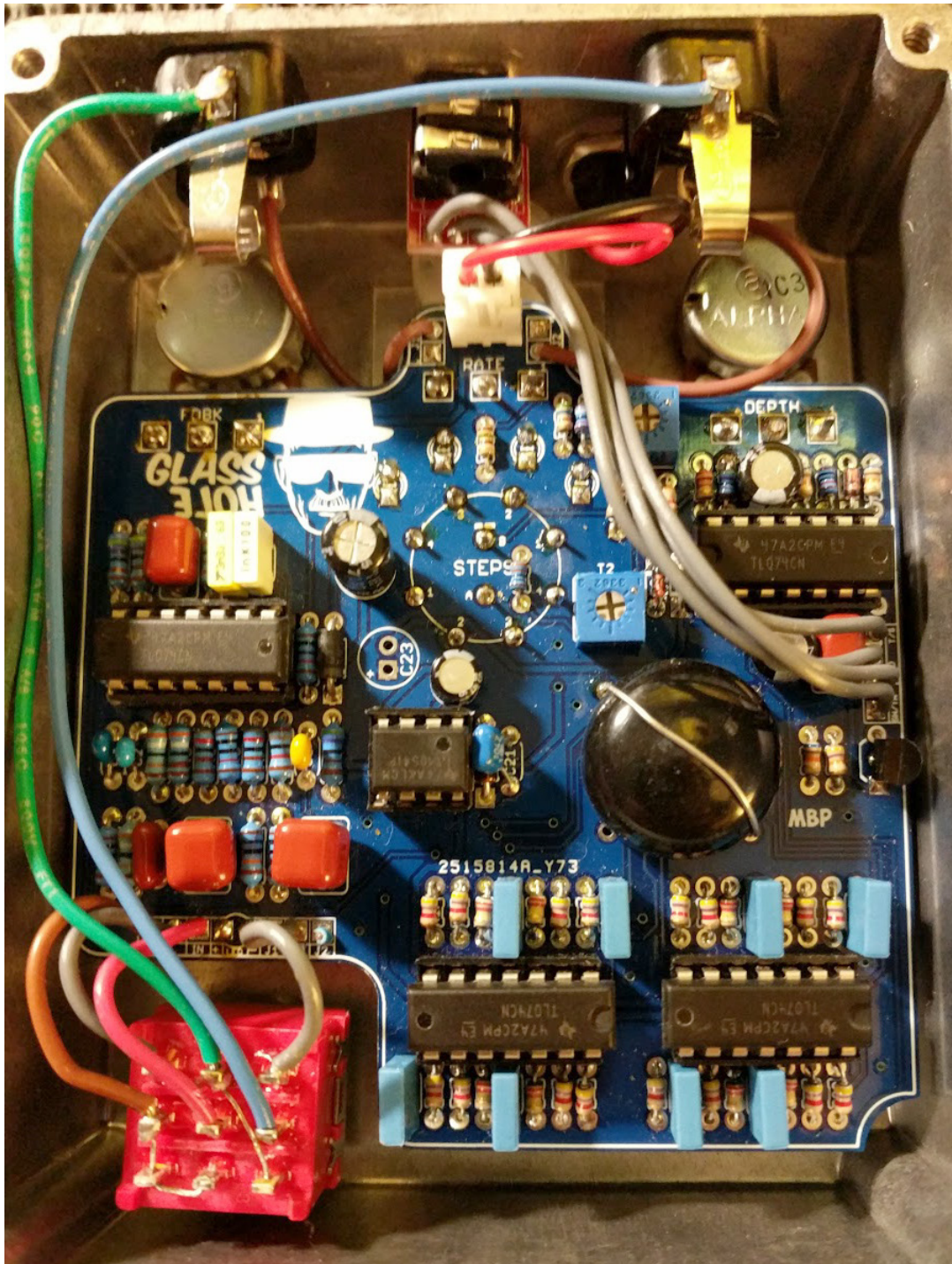

“C23” is empty on this PCB for reasons not important. It was my prototype so there were a few tweaks made after this build.

Updated image shows wiring correction for bypass ticking problem.

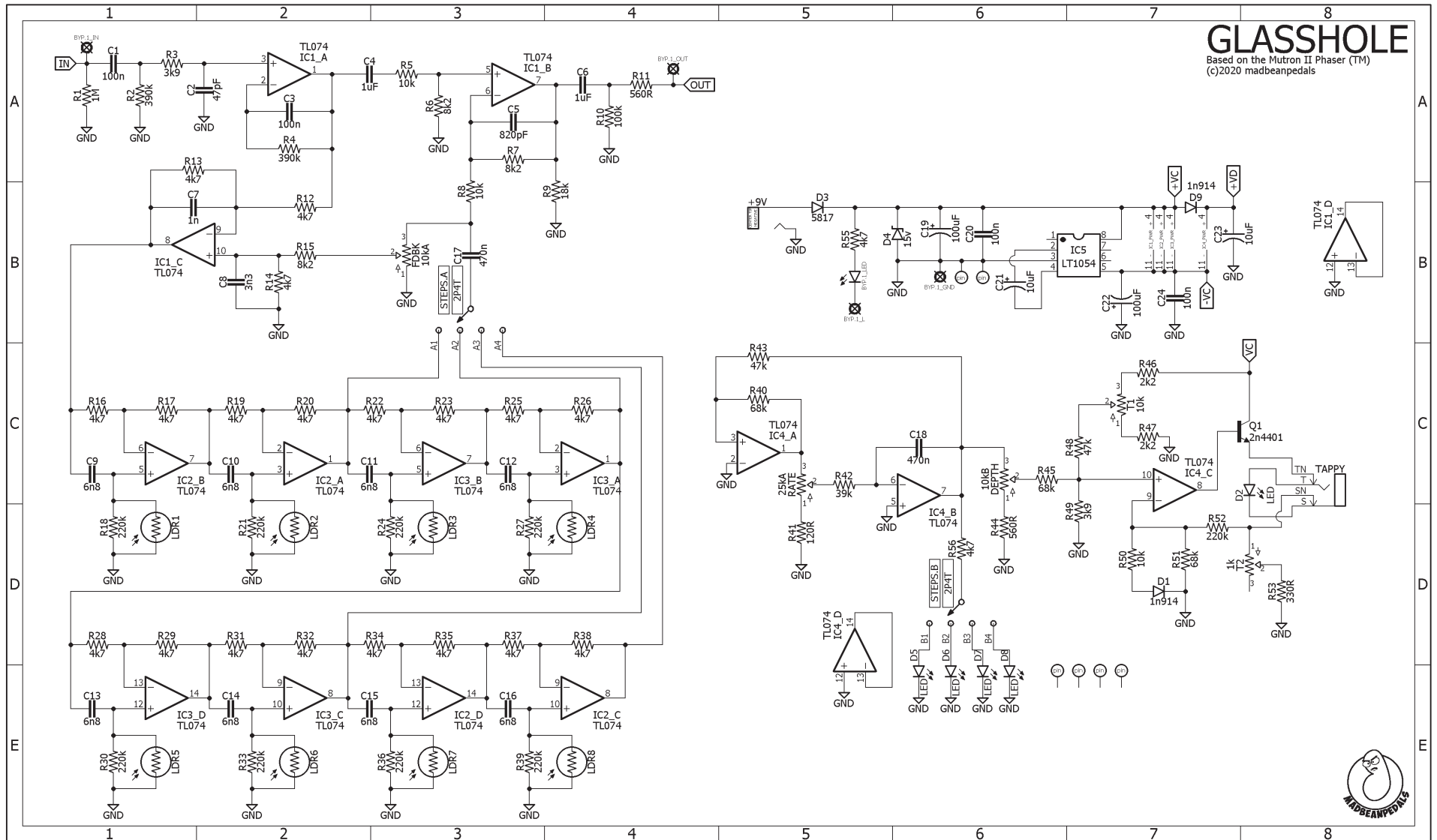

Problem:

Q1 collector has no power connection.

Solution:

A bit of wire or leftover lead needs to be soldered between R46 and the anode of D9.

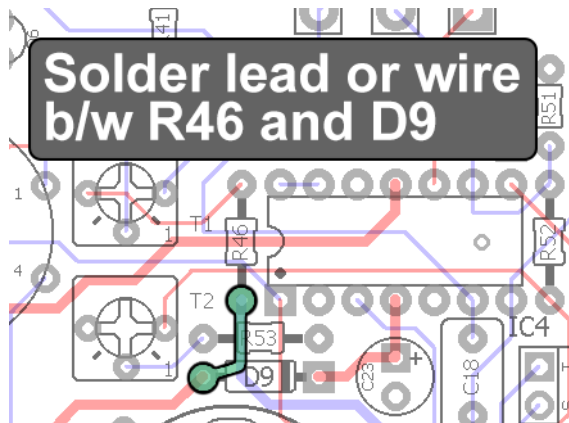

2020 version

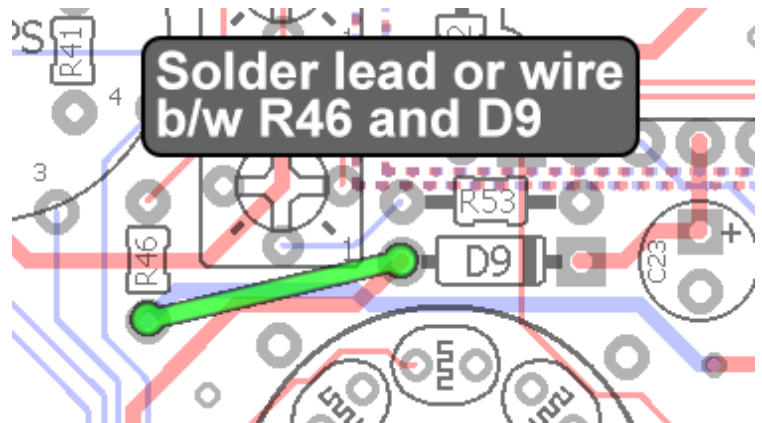

rev.1 (2022)

Fortunately, this should be easy to do. If you are building the Glasshole new, solder D9 first, then put in R46 and fold over the excess lead to D9 and solder. If you have already built the board, just use some extra lead or a small strip of wire. Obviously, this is done on the bottom of the PCB so be sure you have the right spots before you solder.

How did this happen?? You SUCK!

On the Glasshole prototype, I had the Q1 collector connected to +VD. I realized after the fact that it was supposed to be connected to +VC. So, I changed this connection for the final production board. However, I named the net in Eagle incorrectly. If you look at the schematic it says "VC" not "+VC"! Therefore the part only connected to R46 and not the power rail.

This is why there is a voltage reading on my Q1 collector and the mistake went into the production

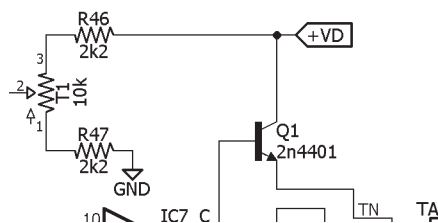

Prototype schematic with incorrect connection. BAD BEAN!