

COLLOSALUS 2015

FX Type: Flanger

Based on the MXR® 117™

Download the previous version documentation here:

<http://www.madbeanpedals.com/projects/Collosalus/Collosalus.zip>

3.25" W x 2.9" H

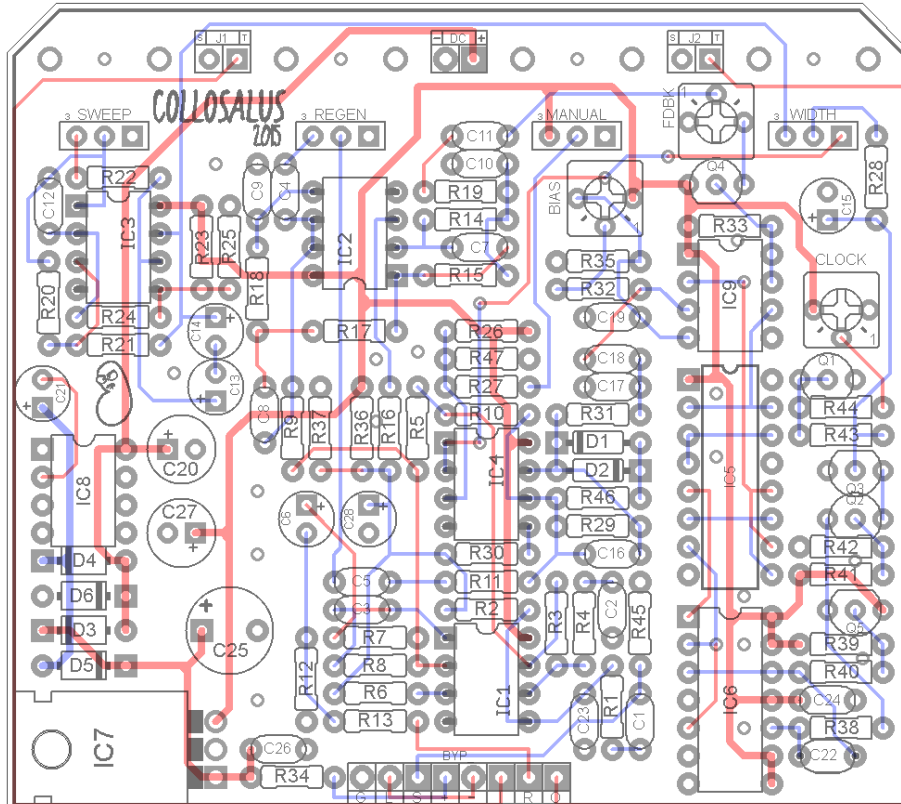
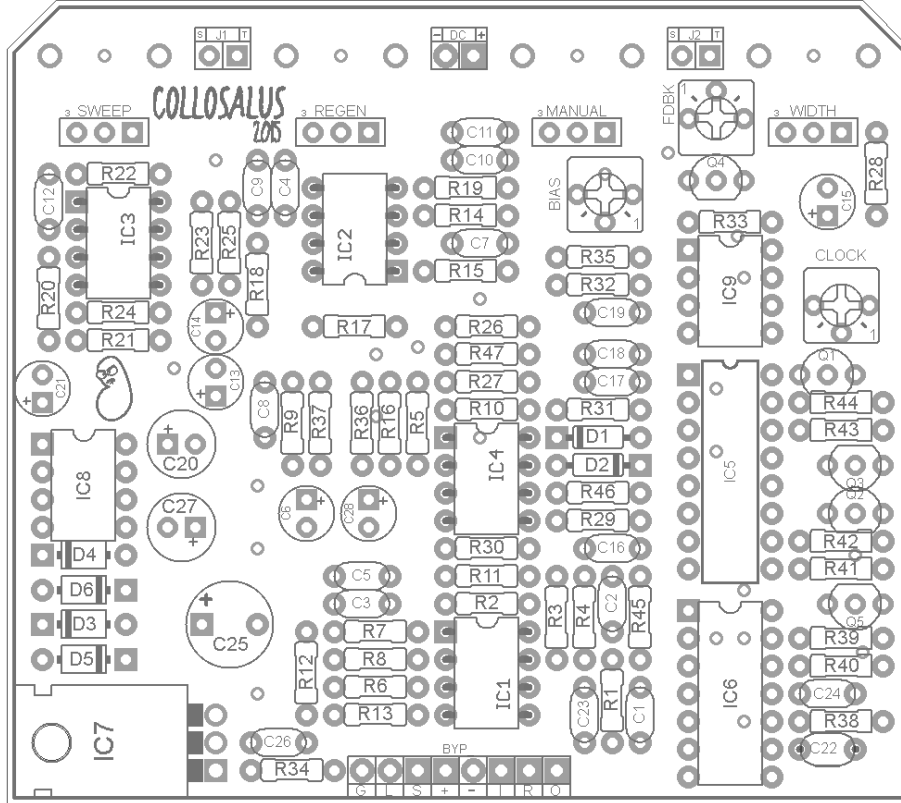

B.O.M.					
Resistors		Caps		Diodes	
R1	1k	C1	100n	D1, D2	1N914
R2	470k	C2	33n	D3 - D5	1N5817
R3	10k	C3	3n3	D6	12v Zener
R4	1k	C4	100n	Transistors	
R5	150k	C5	15n	Q1 - Q4	BC549C
R6	30k	C6	2u2	Q5	2N5087
R7	100k	C7	150pF	IC	
R8	10k	C8	6n8	IC1	NE5532
R9	82k	C9	3n3	IC2	4558
R10	150k	C10	6n8	IC3	4558
R11	120k	C11	100n	IC4	4558
R12	10k	C12	10n	IC5	CD4049UBE
R13	1k	C13	15uF	IC6	CD4013
R14	5k1	C14	15uF	IC7	LM7815
R15	30k	C15	10uF	IC8	LT1054
R16	30k	C16	100pF	IC9	MN3007
R17	7k5	C17	10n	Trimpots	
R18	2k4	C18	100n	CLOCK	500k
R19	30k	C19	100n	BIAS	20k
R20	100k	C20	100uF	FDBK	20k
R21	75k	C21	47uF	Pots	
R22	4k7	C22	***	MANUAL	50kB
R23	15k	C23	51pF	REGEN	50kB
R24	100k	C24	100n	SWEEP	500kC
R25	16k	C25	470uF	WIDTH	50kB
R26	470k	C26	100n		
R27	100k	C27	100uF		
R28	1M	C28	10uF		
R29	100k				
R30	30k				
R31	1k				
R32	100k				
R33	47k				
R34	22k				
R35	2k4				
R36	30k				
R37	30k				
R38	330R				
R39	3k				
R40	30k				
R41	62k				
R42	10k				
R43	22k				
R44	470k				
R45	2M2				
R46	27k				
R47	470k				

C22 - 47pF - 62pF

C22 is 62pF in the stock 117, however I found 47pF works better in the Collosalus.

Shopping List

Value	QTY	Type	Rating	Value	QTY	Type	Rating
330R	1	Metal / Carbon Film	1/4W	3n3	2	Film	25v min.
1k	4	Metal / Carbon Film	1/4W	6n8	2	Film	25v min.
2k4	2	Metal / Carbon Film	1/4W	10n	2	Film	25v min.
3k	1	Metal / Carbon Film	1/4W	15n	1	Film	25v min.
4k7	1	Metal / Carbon Film	1/4W	33n	1	Film	25v min.
5k1	1	Metal / Carbon Film	1/4W	100n	7	Film	25v min.
7k5	1	Metal / Carbon Film	1/4W	2u2	1	Electrolytic	25v min.
10k	4	Metal / Carbon Film	1/4W	10uF	2	Electrolytic	25v min.
15k	1	Metal / Carbon Film	1/4W	15uF	2	Electrolytic	25v min.
16k	1	Metal / Carbon Film	1/4W	47uF	1	Electrolytic	25v min.
22k	2	Metal / Carbon Film	1/4W	100uF	2	Electrolytic	25v min.
27k	1	Metal / Carbon Film	1/4W	470uF	1	Electrolytic	25v min.
30k	8	Metal / Carbon Film	1/4W	1N914	2		
47k	1	Metal / Carbon Film	1/4W	1N5817	3		
62k	1	Metal / Carbon Film	1/4W	12v Zener	1		1W
75k	1	Metal / Carbon Film	1/4W	BC549C	4		
82k	1	Metal / Carbon Film	1/4W	2N5087	1		
100k	6	Metal / Carbon Film	1/4W	NE5532	1		
120k	1	Metal / Carbon Film	1/4W	4558	3		
150k	2	Metal / Carbon Film	1/4W	CD4049UBE	1		
470k	4	Metal / Carbon Film	1/4W	CD4013	1		
1M	1	Metal / Carbon Film	1/4W	LM7815	1		
2M2	1	Metal / Carbon Film	1/4W	LT1054	1		
47pF	1	Ceramic	25v min.	MN3007	1		
51pF	1	Ceramic	25v min.	500k	1	Bourns 3362P	
62pF	1	Ceramic	25v min.	20k	2	Bourns 3362P	
100pF	1	Ceramic	25v min.	50kB	3	PCB Mount	9mm
150pF	1	Ceramic	25v min.	500kC	1	PCB Mount	9mm

Changes to the 2015 edition

- Tweaked the power supply section.
- Changed from 16mm to 9mm pots for allow for top mounted jacks.

9mm Alpha pot: <http://smallbear-electronics.mybigcommerce.com/alpha-single-gang-9mm-right-angle-pc-mount/>

Terms of Use: You are free to use purchased **Collosalus** circuit boards for both DIY and small commercial operations. You may not offer **Collosalus** PCBs for resale or as part of a "kit" in a commercial fashion. Peer to peer re-sale is, of course, okay.

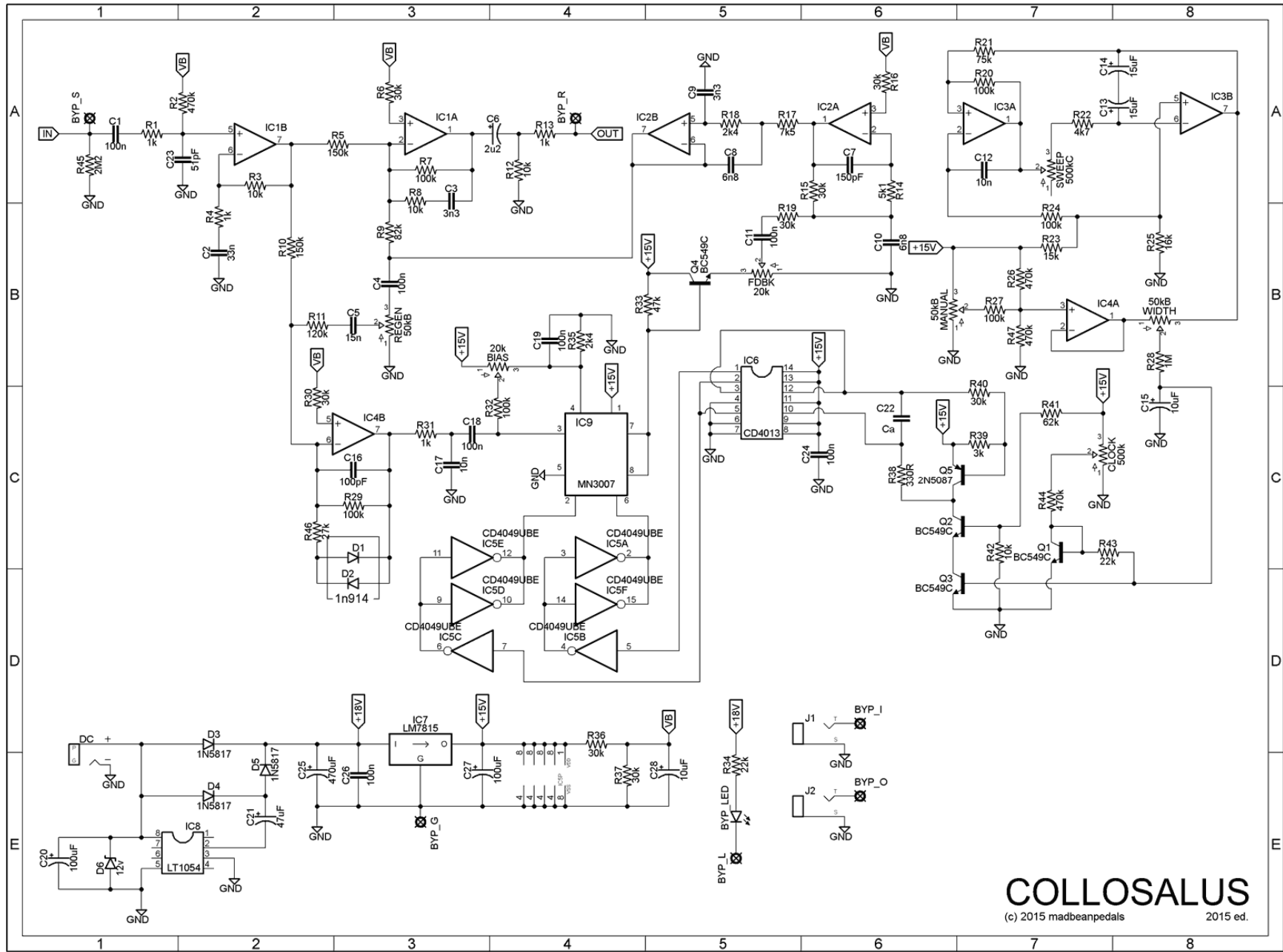

COLLOSALUS

(c) 2015 madbeanpedals 2015 ed.

1590BB Drill Guide

5.8" W x 6.8" H

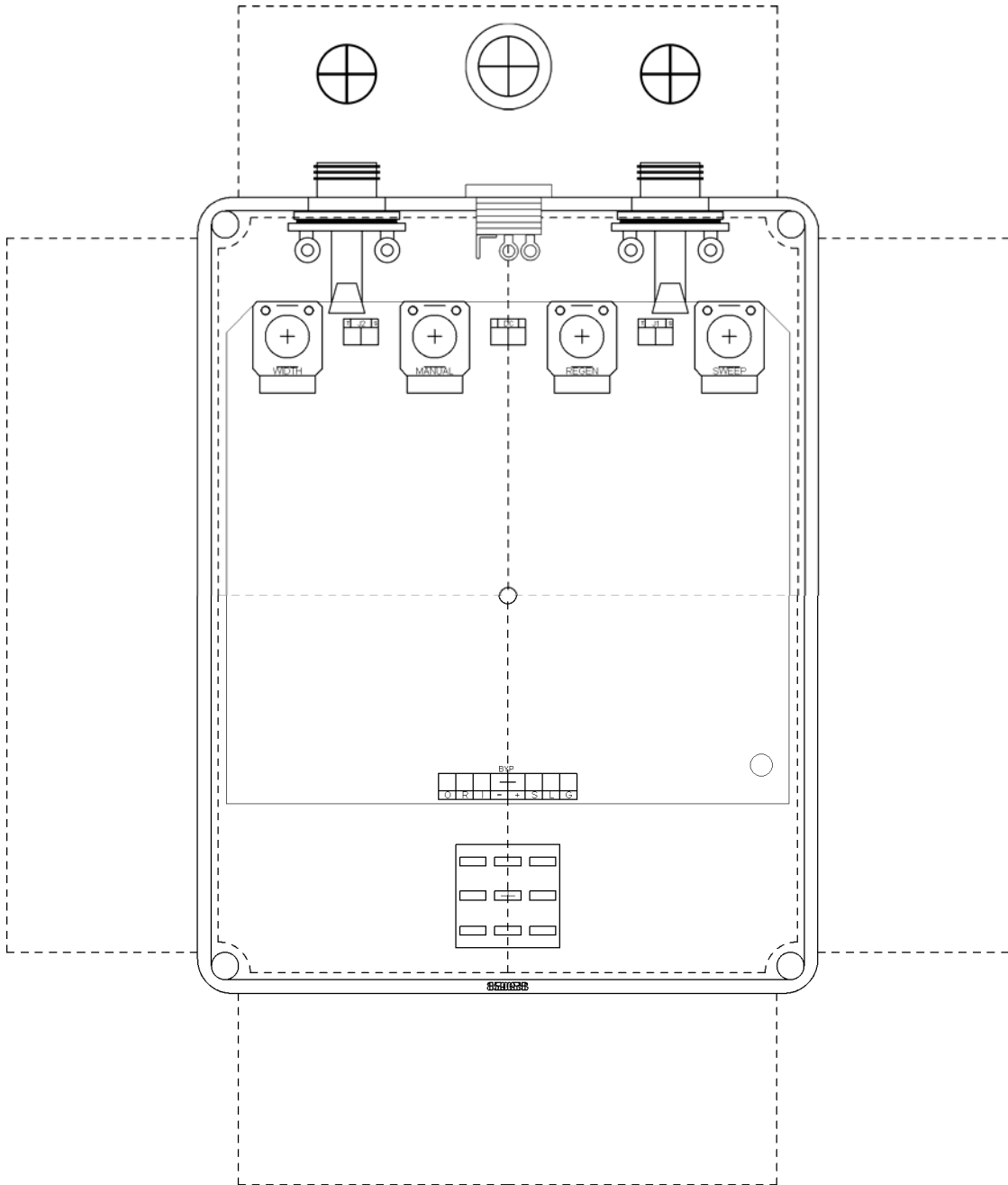

Download the Photoshop file used to make this template here:
http://www.madbeanpedals.com/projects/Collosalus/Collosalus_DRILL.zip

Wiring Guide

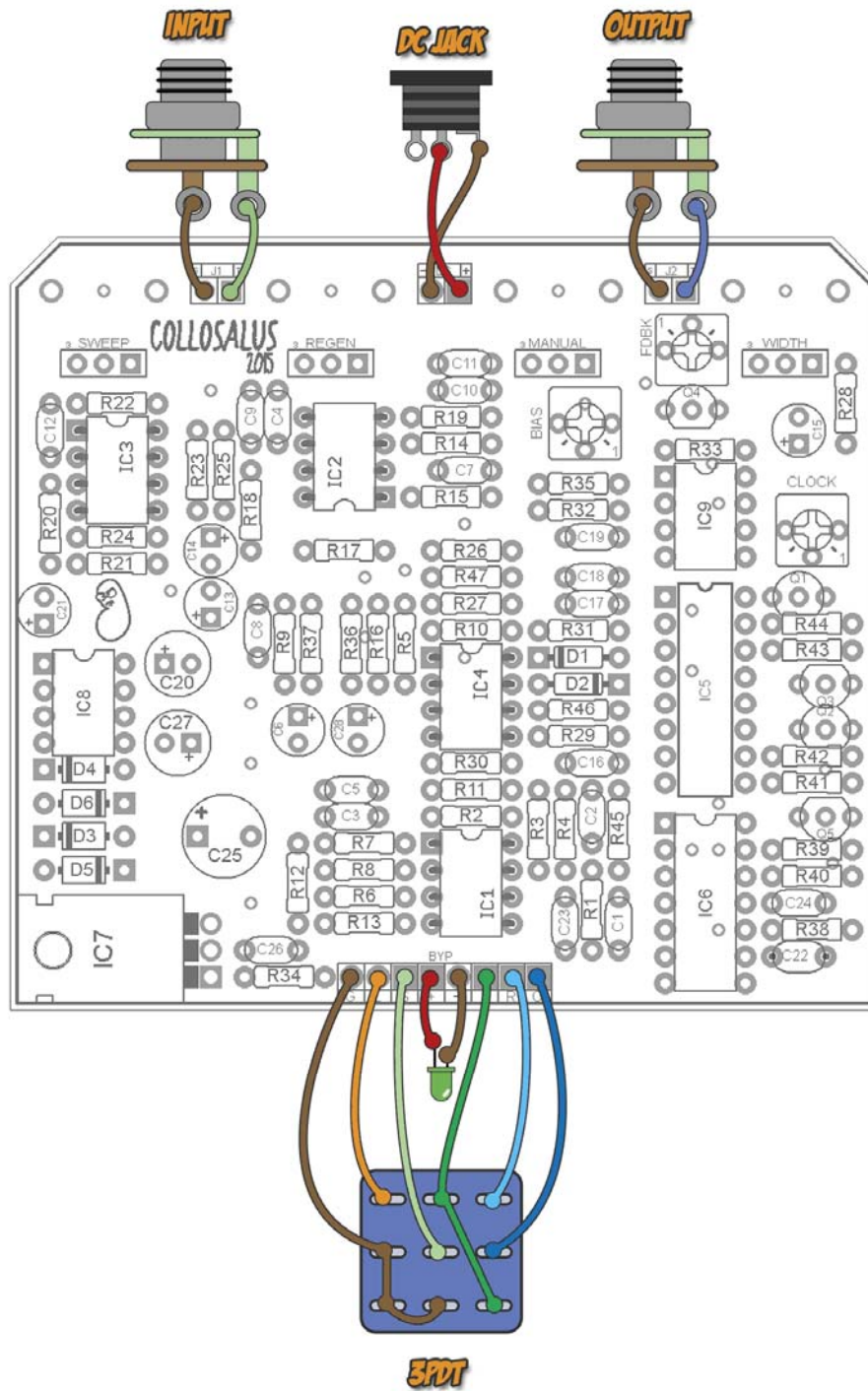

TIP: You can wire the LED to wherever you like, or simply solder it directly to the PCB.

Voltages

IC1	
1	7.41
2	7.41
3	7.39
4	0
5	7.09
6	7.42
7	7.42
8	14.82

IC2	
1	7.41
2	7.41
3	7.39
4	0
5	7.41
6	7.42
7	7.42
8	14.82

IC3	
1	vaires
2	7.61
3	vaires
4	0
5	7.69
6	7.69
7	vaires
8	14.82

IC4	
1	7.06
2	7.06
3	6.99
4	0
5	7.38
6	7.41
7	7.41
8	14.82

IC5	
1	14.81
2	7.38
3	7.38
4	7.38
5	7.38
6	7.38
7	7.38
8	0
9	7.38
10	7.38
11	7.38
12	7.38
13	~ mV
14	7.38
15	7.38
16	~ mV

IC6	
1	7.38
2	7.38
3	12.53-13.89
4	0
5	0
6	0
7	0
8	14.82
9	14.82
10	10.98-11.63
11	14.82
12	12.55-13.89
13	14.82
14	14.82

IC7	
1	21.8
2	0
3	14.82

IC8	
1	1.42
2	6.33
3	0
4	7mV
5	100mV
6	2.34
7	1.46
8	12

IC9	
1	14.81
2	7.37
3	6.12
4	1.54
5	0
6	7.37
7	4.7-5.67
8	4.7-5.67

These voltages were measured on the previous Collosalus PCB using a regulated 12vDC 200mA supply. A 9v supply will show similar results except for IC8 pin8 and IC7 pin1. These pins will read around 9v and 18v resp. when using a 9v supply instead of 12v.

Keep in mind that some of the voltages here will change some depending on where your trimmers and knobs are set. These are intended as a rough guide only, should you need a reference point in building the project.

The **Collosalus** is an updated version of the classic MXR-117 Flanger. The MXR-117 utilizes just a few simple controls to produce a range of deep and resonant flange to fast liquid-like chorus effects. The Collosalus makes several key updates to the original design taking into consideration the lack of availability of the original SAD1024 BBDs and transformer-based power supply. These include conversion to MN3007 operation and a charge pump based supply.

The Collosalus ranks as a difficult build due to the number of components and complexity of the effect. However, the reward is a unique and instantly recognizable effect that has been popularized for decades.

Special thanks for madbeanpedals forum member “Scruffie” who supplied feedback during the development process of this project. Thanks also to www.shredaholic.com and www.diystompboxes.com which also served as a source of information in realizing this design.

- **Sweep:** Controls the rate of the low-frequency oscillator which drives the flanger.
- **Regen:** Sets the amount of feedback into the flanger which results in increased intensity of the effect.
- **Manual:** Sets the resonant frequency that is swept through the flanger when the Width control is set low. The Manual control also works interactively with Regen and can produce metallic, steel-drum types of tones.
- **Width:** Sets the overall depth of the flanging effect.

NOTES

There are two changes to the 2015 edition of the Collosalus. The first change converts the 16mm pots of the previous version to 9mm pots and the re-routes the I/O. With the 2015 version, you have the option of top mounting the input, output and DC jack. Additionally, all the remaining wired I/O pads are centrally located at the bottom of the PCB for the cleanest wiring possible to your 3PDT.

The second change is in the power supply section. The original 117 flanger was powered via mains and then converted into 15vDC via a transformer. The previous version of the Collosalus instead powered the effect via a 9v supply, a charge pump and 15v regulator. However, at least a few builders reported problems with extra noise using this method. So, the 2015 version offers the option of either 9v power or 18v power. The 9v method still uses a charge pump to go up to 18v and then regulates down to the 15v supply used in the effect. The 18v method does not use a charge pump but regulates the 18v down to 15v directly.

I suggest trying the 9v version first, and if you have noise problems, convert it to use an 18vDC supply instead. Fortunately, this is very easy to do on the Collosalus.

For the 9v method populate everything on the board EXCEPT D3. You must leave this diode off for the voltage to come out correctly.

For the 18v method populate D3, and omit IC8, D4, D5, D6, C20 and C21.

R45 is an optional pull-down resistor not featured in the original design. 1M – 2M2 is suggested. I found my own build did not need it since there was no excessive “pop” when engaging the effect.

C22 should be socketed. This capacitor determines the clock frequency at which the CD4013 supplies the BBD. The vintage unit lists 62pF as the nominal value for driving the SAD1024, but I found that a 47pF worked best in my own build. Smaller values will reduce noise but also make the flanger effect more shallow.

BIASING

- Set Manual fully counter-clockwise, Width and Regen about $\frac{1}{2}$ up, and Sweep about $\frac{1}{4}$ up.
- Position the CLOCK and BIAS trims $\frac{1}{4}$ up and the FDBK $\frac{1}{2}$ up.
- Apply power to the effect. Adjust the BIAS trim in small increments until you hear the effect start to sweep. Find the positions left and right on the trimmer where the sweeping stops, and then set the BIAS trimmer halfway between those two points. Now adjust the CLOCK trimmer left and right. In the left most position the bottom of the sweep will tend to flatten out at the most extreme. As you turn the trimmer up, the range of the sweep will decrease and become more shallow. Set this trimmer so that you get the highest depth possible while keeping the up and down portion of the sweep as symmetrical as possible. I found this to be about $\frac{1}{4}$ up on the trimmer.
- Set the Regen fully clockwise. Now adjust the FDBK trimmer to increase the maximum amount of feedback you can achieve before it begins to self-oscillate. You will hear this as a loud “sproing” at the bottom of the flanger's sweep. Back off the trimmer from this position until the “sproing” goes away.