

MANGLER

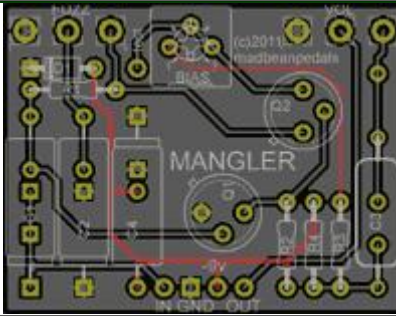

FX TYPE: FUZZ

PCB artwork ©2011 madbeanpedals
Release date: 06.01.11

The **Mangler** will allow you to build a vintage Fuzz Face™ using either NOS PNP germanium transistors or more modern silicon-based transistors. The PCB is fitted with extra pads to accommodate different lead spacing depending on whether axial or radial capacitors are used. A bias trimmer and test point have also been added for convenience.

Build Notes

This is a positive ground effect! It is necessary to use either battery, a power supply with isolated 9v supplies like the Voodoo Pedal Power or a voltage converter like the Road Rage to power the effect. Current draw is very low without an LED, so a battery will last a very long time.

To bias the **Mangler**, connect the black lead from your DMM to the test point pad next to the **BIAS** trimmer on the PCB and the red lead to ground. Adjust the trimmer until it reads approximately -4.5v. If you are building the negative ground NPN fuzz, the process is the same, however reverse the red and black leads of your DMM.

The electrolytic capacitors on the PCB silkscreen illustrate positive and negative orientation for a positive ground, PNP-based fuzz. If you wish to build a negative ground, NPN-based fuzz, flip the electrolytic caps around the opposite way. You will also need to flip the 1N4001 diode and wire +9v (red) to the -9v pad and ground (black) to the ground pad.

The **Mangler** does not have a pulldown resistor. If you wish to add a pulldown, place it between the effect input and one of the grounded lugs on your 3PDT (where the orange and red wires connect on the wiring diagram below). Most likely this will not be necessary.

If you have never purchased PNP germanium transistors before, you can find several variations and offerings at www.smallbearelec.com. These transistors are tested for gain and leakage beforehand. Smallbear also provides resistor values to properly bias the pair of transistors you purchase. Please feel free to use those values instead of the ones listed in the BOM of the **Mangler**. There are also numerous types of NPN silicon transistors that will work for a negative ground version. Suggestions are BC108, BC109, 2n3904, 2SC828, and 2SC1815. Make sure to check for the proper pin-out of the transistors you choose. The tabs on the silk screen of the **Mangler** PCB indicated the emitter of **Q1** and **Q2**.

You may also use PCB-mounted 16mm pots for this PCB: <http://www.smallbearelec.com/Detail.bok?no=692>

LAYOUT DIAGRAM

1.875" W x 1.45" H

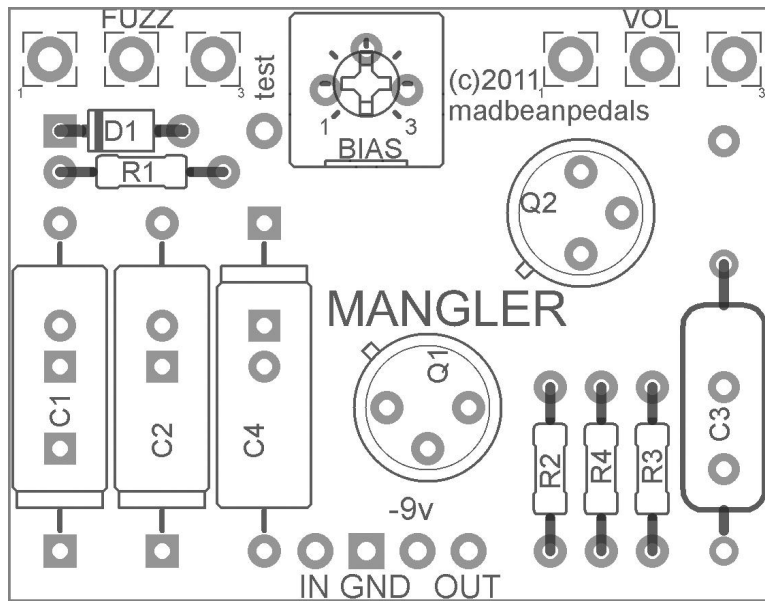

This PCB will fit in a 1590B

BILL OF MATERIALS

Resistors		Diodes	
R1	100k	D1	1N4001
R2	33k	Transistors	
R3	220R	Q1, Q2	PNP GE
R4	470R	Trimmer	
Caps		BIAS	20k
C1	2u2	Pots	
C2	22uF	FUZZ	1kB
C3	10n	VOL	500kA
C4	47uF		

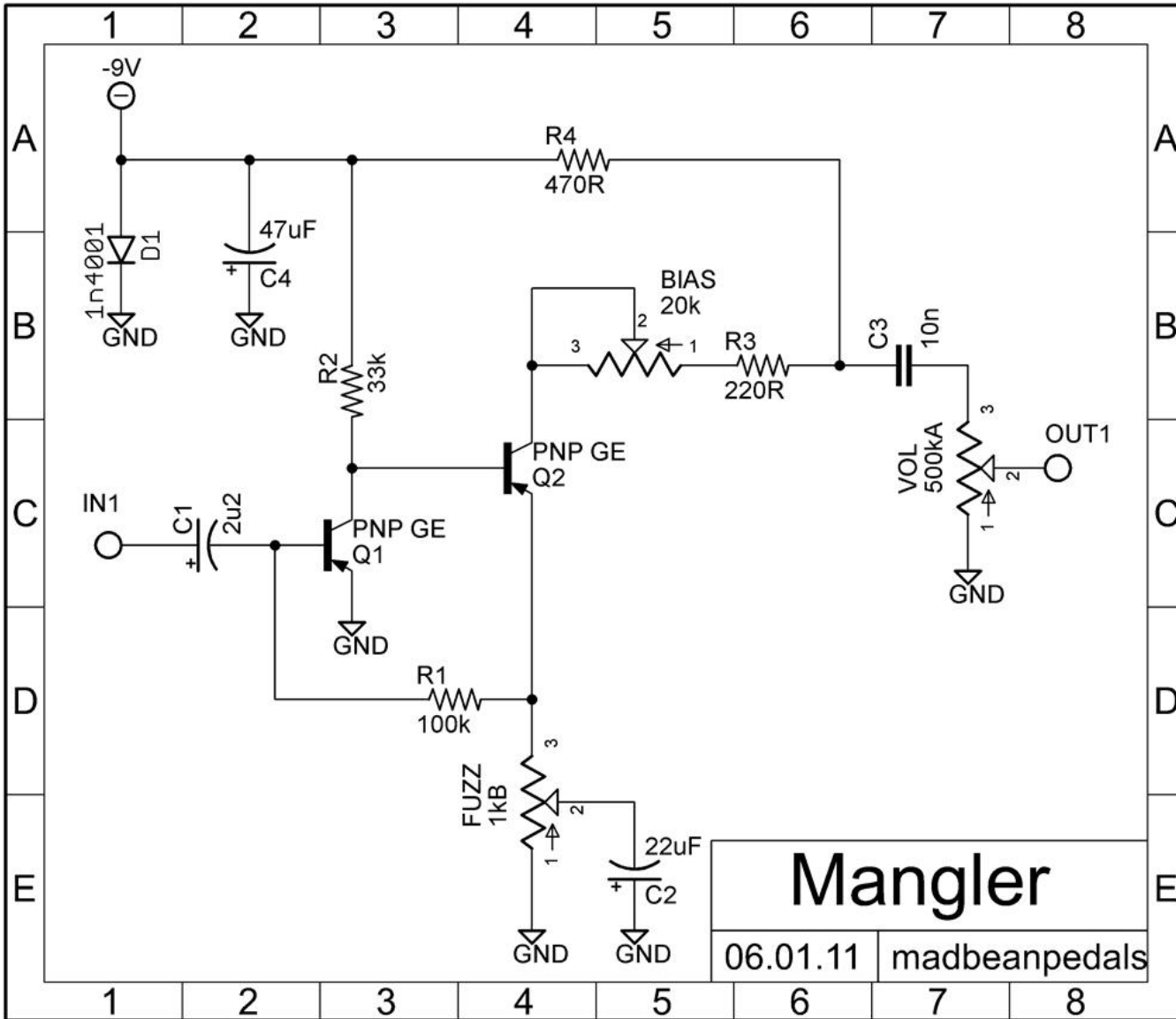

MANGLER WIRING DIAGRAM

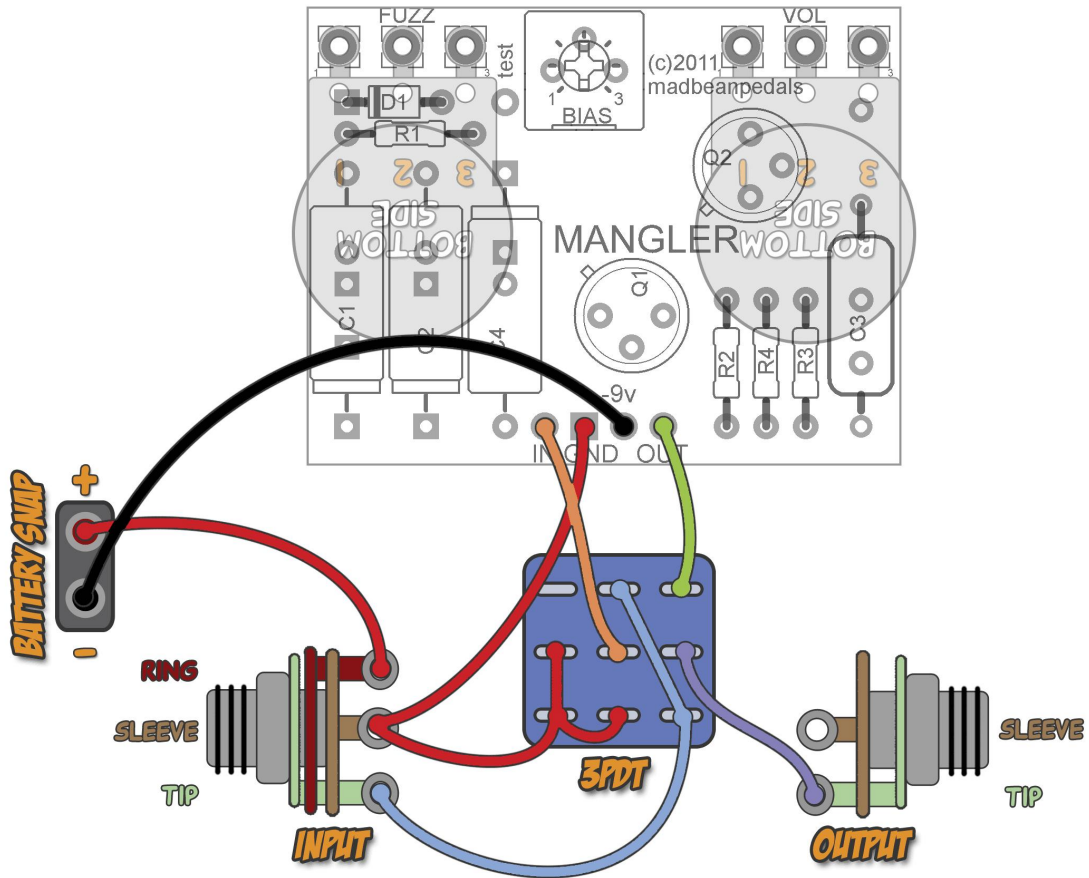

LED W/ A POSITIVE GROUND EFFECT

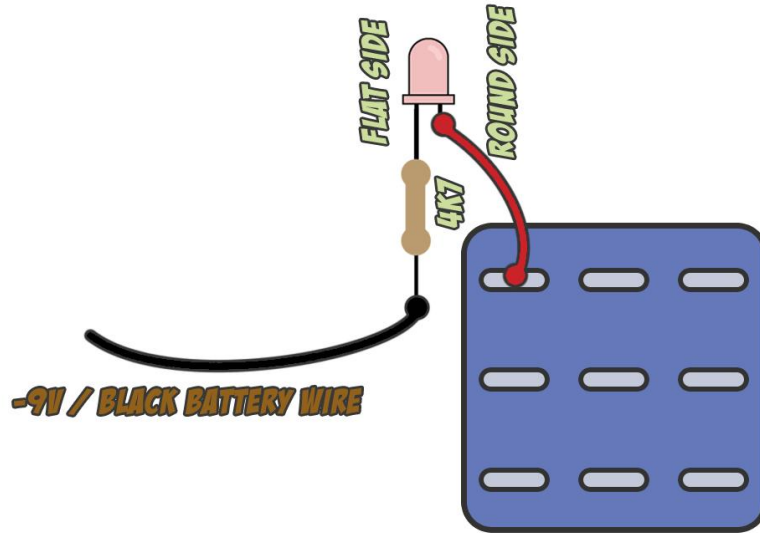

ALL OTHER LUGS WIRED AS NORMAL

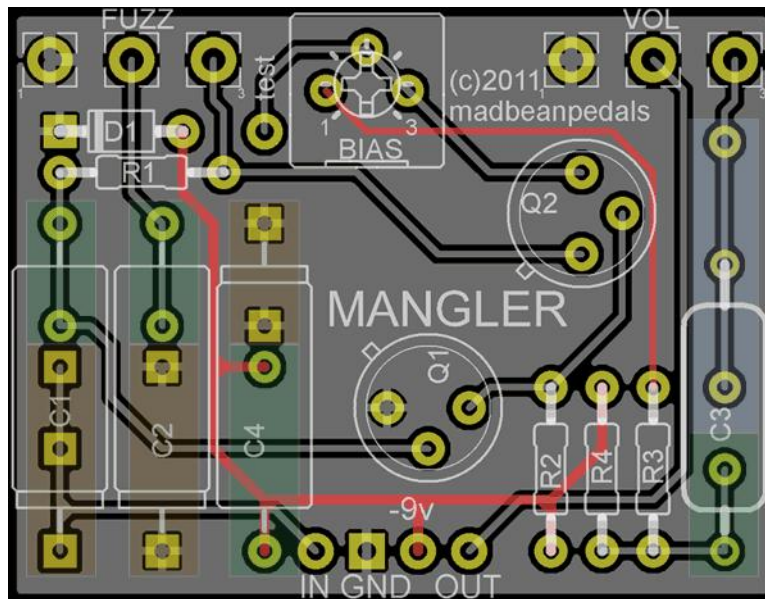

Highlighted zones illustrate which pads correspond to the leads on C1 - C4.

Terms of Use

This PCB may be used freely for commercial applications without prior permission or notification. There is no license required to do so.

