

# PEPPER SPRAY

**FX TYPE: FUZZ**

Based on the Interfax® Harmonic Percolator™

PCB artwork ©2011 madbeanpedals

Release date: 09.26.11 – fabbed version

The Harmonic Percolator™ is a very, very rare and mysterious fuzzbox. Not many Interfax® production units were made in its short life-span. However, in the last few years there has been a resurgence of interest and at least a couple of companies have offered clones at one time or another.

If you've never heard of this beast, I suggest you watch these:

<http://www.youtube.com/watch?v=nahPA-RKEfQ>

[http://www.youtube.com/watch?v=7278zg\\_UQKQ](http://www.youtube.com/watch?v=7278zg_UQKQ)

<http://www.youtube.com/watch?v=XzNXKrMynW4>

The thing that sets the Percolator apart from other fuzzes is its dynamic response, microphonic feedback and the subtle lower octave you can sometimes get from it. It is an unwieldy beast, and truly sounds best with its controls at maximum.

The Percolator does not seem to have one “stock” design. Slight changes were made in component values over its life-cycle. Therefore, determining what constitutes the “ultimate” version involves some guess-work. The **Pepper Spray** is presented with two separate bills of materials. One is what some consider the stock version and the other is the Steve Albini version demonstrated in the video links above. The Albini version is also the one shown in the **Pepper Spray** schematic below. These are the exact values that were used in and measured from his unit. Special thanks to freestompboxes where this information was disseminated!

The **Pepper Spray** design also includes a switch for toggling diodes. Note that there are several extra holes on the PCB for **C2**, **C7** and **C5** to allow for different lead spacing.

## The controls are as follows

**HARM:** This is the “Harmonics” control. It adjusts the amount of signal fed into the input of the effect.

**BAL:** The total volume output.

**SW:** This SPDT (On/Off/On) lets you choose between stock clipping, no clipping and one other of your choosing.

## Links with detailed information and analysis of the *Harmonic Percolator*

<http://www.diystompboxes.com/smfforum/index.php?topic=68649.0>

<http://www.freestompboxes.org/viewtopic.php?f=19&t=6675>

## Notes

- For the **D4&D5** diodes, you can try any number of different types. I suggest not using germanium to give you more variety. I liked two BAT41s in series for each diode slot, but 1n914 would also work well. Other possibilities are LEDs or a mixture of different types.
- Be careful when soldering the 1n695. They seem to be more sensitive to heat than other germanium diodes I have used. I melted both of mine when trying to de-solder them and put them on a different board. Use sockets!

### For this project, I specifically recommend ordering these components from Smallbear:

2n404a: <http://www.smallbearelec.com/Detail.bok?no=1052>

1n695: <http://www.smallbearelec.com/Detail.bok?no=854>

2n3565: <http://www.smallbearelec.com/Detail.bok?no=282>

100pF Silver Mica: <http://www.smallbearelec.com/Detail.bok?no=181>

47uF Tantalum: <http://www.smallbearelec.com/Detail.bok?no=983>

2u2 Tantalum: <http://www.smallbearelec.com/Detail.bok?no=560>

### I used these for my caps:

47n (Mallory – sub for 50n): <http://www.smallbearelec.com/Detail.bok?no=519>

100n (Mallory): <http://www.smallbearelec.com/Detail.bok?no=520>

Note: This 100n will be larger than the PCB. If you use it, you will need to fold the bottom lead under the cap and then down to fit in the allotted space. It will hang over the board a little.

1n5 (Panasonic): <http://www.smallbearelec.com/Detail.bok?no=162>

For resistors, I suggest using carbon film except for R2 and R4. Use metal film for those, if possible. **C6** is for power supply filtering and can be a generic 16-25v electrolytic cap.

## Fabbed Version Notes

- **C2**, **C5**, and **C7** have extra holes to allow for either axial or radial caps.
- You can use 16mm PCB pin pots and a solder lug SPDT mounted directly to the PCB, if desired.

# Layout

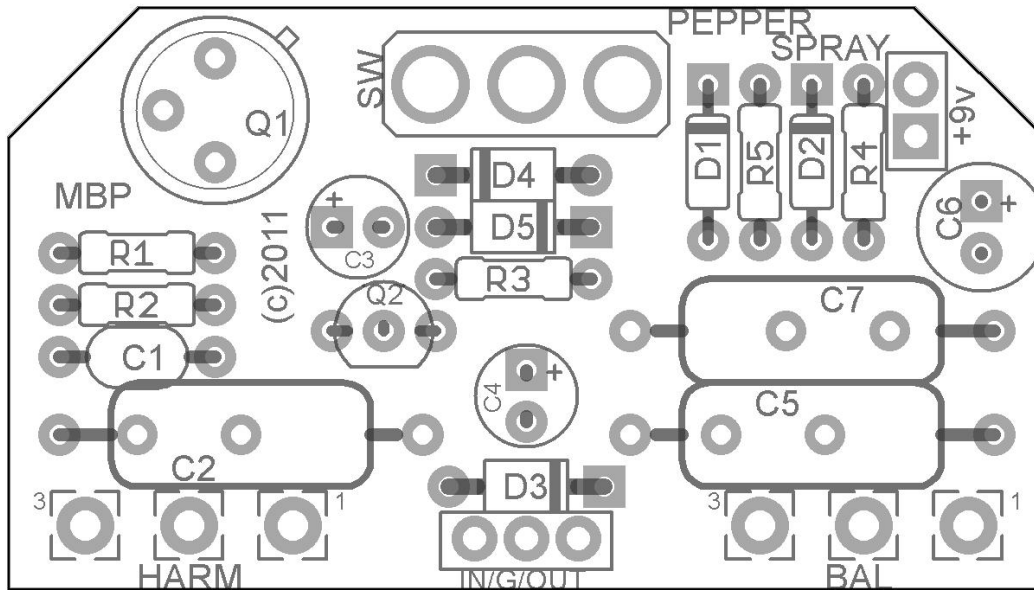

Ailbini				"Stock"							
Resistors		Caps		Diodes		Resistors		Caps		Diodes	
R1	51k	C1	100pF	D1, D2	1n695	R1	220k	C1	100pF*	D1, D2	1n695
R2	91k	C2	50n	D3	1N4001	R2	20k	C2	50n	D3	1N4001
R3	3M9	C3	47uF	D4, D5	**	R3	750k	C3	47uF	D4, D5	**
R4	91k	C4	2u2	<b>Transistors</b>		R4	91k	C4	1uF**	<b>Transistors</b>	
R5	4k7	C5	1n5	Q1	2n404a	R5	4k7	C5	1n***	Q1	2n404a
		C6	100uF	Q2	2N3565			C6	100uF	Q2	2N3565
		C7	100n	<b>Pots</b>				C7	100n	<b>Pots</b>	
		<b>Switch</b>		HARM	100kA			<b>Switch</b>		HARM	100kA
		SW	SPDT	BAL	50kA			SW	SPDT	BAL	50kA

\* Also listed as 390pF in some versions  
 \*\* Also listed as 100n in some versions  
 \*\*\* This cap is omitted in some versions

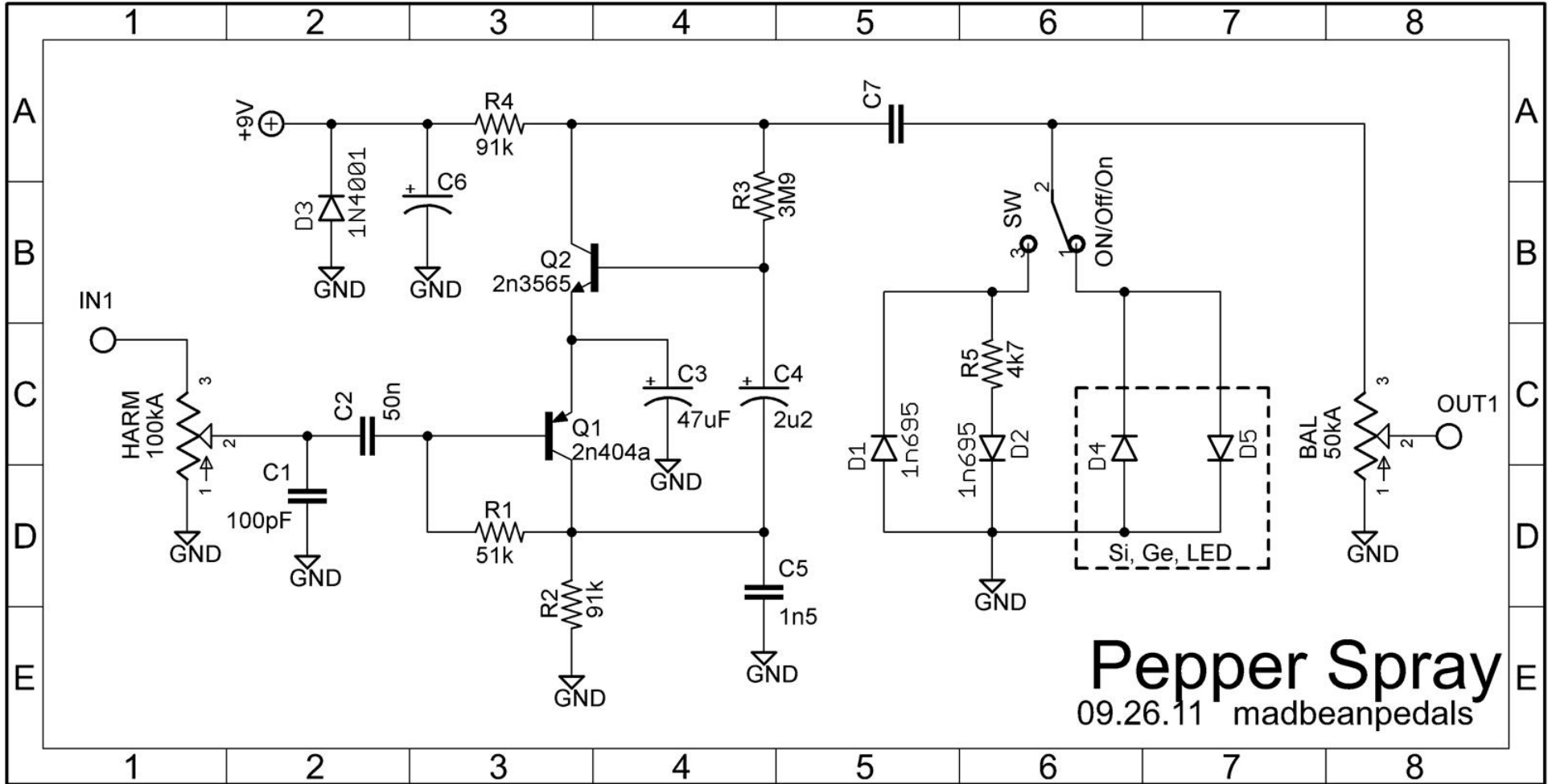

**Pepper Spray**  
09.26.11 madbeanpedals

**1590B Layout**  
**4.64" W x 6.69" H**

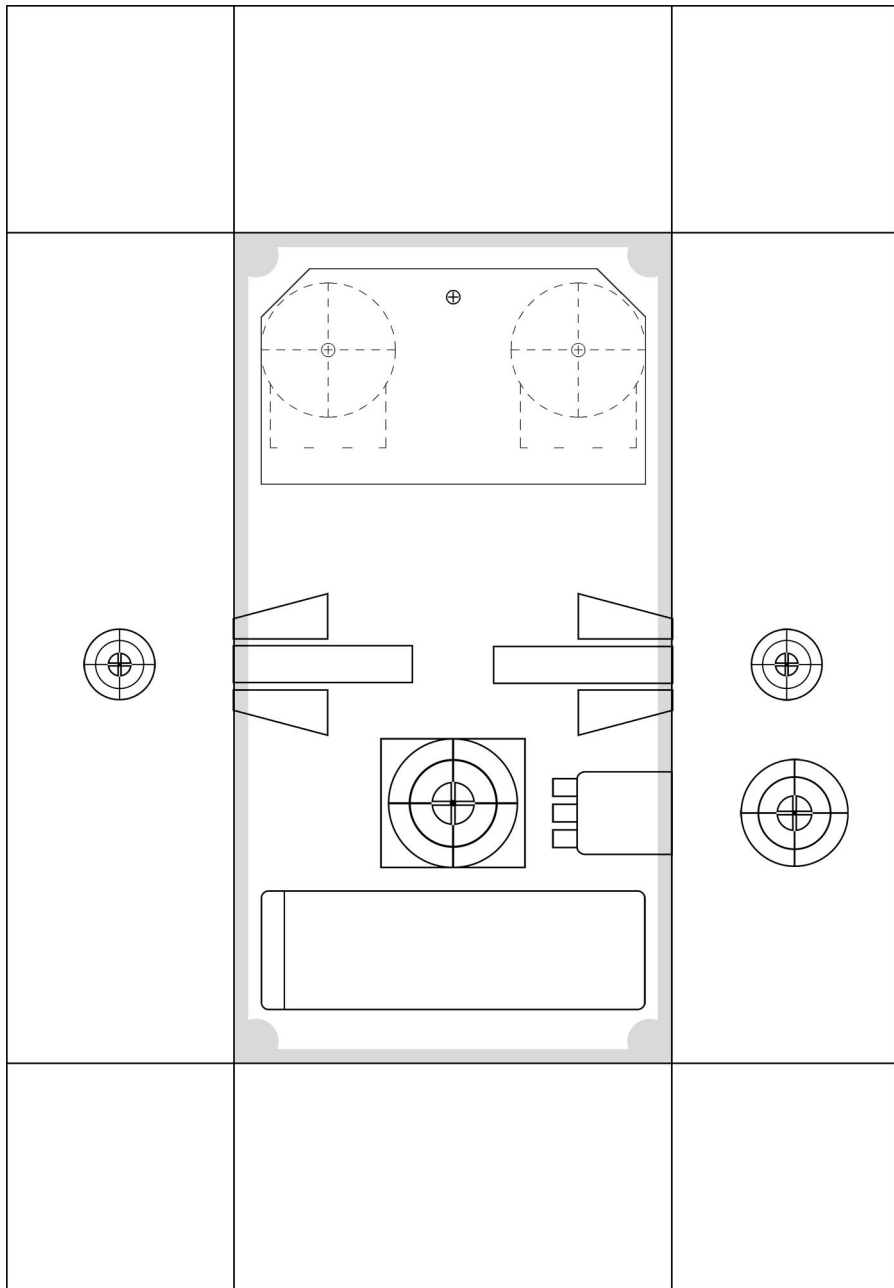

# Etching Layout

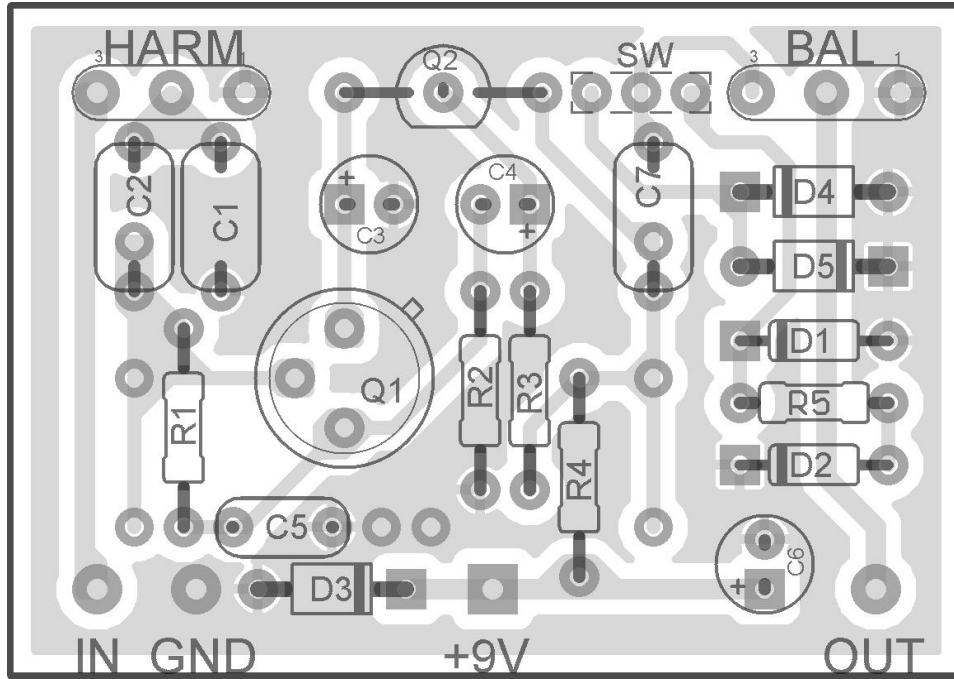

**1.94" W x 1.36" H (including borders)**

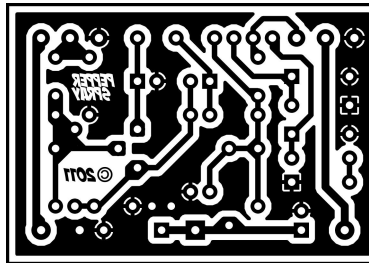

# 3-2-1 POT SHAFT FACES DOWN

