

PORKBARREL

FX TYPE: Chorus

©2011 madbeanpedals · Release date: 09.26.11

The **Pork Barrel** (based on the classic CE-2) has undergone a significant revision for this release. The PCB size has been reduced to fit into a 1590B enclosure, the Tonepad® mods have been eliminated, and for the first time you can build it with the MN3007, MN3207 or v3207 depending on price and availability of BBDs.

What are the advantages of the different BBDs?

The vintage unit used the MN3007. This BBD allows a higher voltage supply than the others. You can safely use 9 – 15v DC to power the effect, with the higher voltage providing additional headroom. Note that if you use 15v, you will want it to be well regulated either by your power supply, or by using a charge pump like the Road Rage. Anything over 15v may damage the MN3007.

The MN3207 and v3207 have lower current requirements, are less expensive and easier to find. These versions require less than 9v to operate correctly. Be sure to see the notes on how to build the different versions.

Special thanks to forum member **Scruffie** who provided assistance in merging the different BBD versions onto one PCB!

Controls

RATE: Sets the speed of the LFO driver for the chorus.

DEPTH: The overall thickness or density of the chorus effect.

Layout Diagram

2" W x 2.4"H

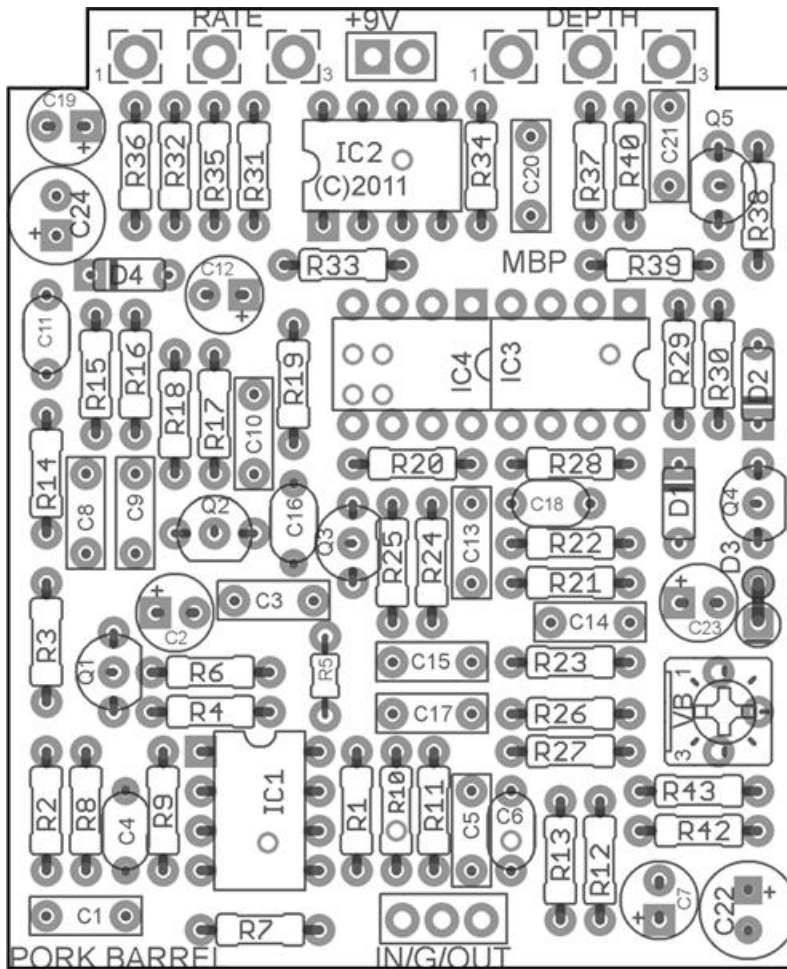

Bill of Materials

Resistors		Resistors		Caps		Diodes	
R1	1M	R26	1M	C1	47n	D1, D2	1N914
R2	1k	R27	47k	C2	1uF	D3	1n4001
R3	470k	R28	33k	C3	6n8	D4	8.2v Zener*
R4	10k	R29	2k7	C4	100pF	Transistors	
R5	10k	R30	150k	C5	6n8	Q1 - Q5	2N5088
R6	47k	R31	10k	C6	100pF	ICs	
R7	10k	R32	10k	C7	1uF	IC1	JRC4558
R8	47k	R33	47k	C8	33n	IC2	TL062
R9	47k	R34	33k	C9	3n3	IC3	MN3101*
R10	47k	R35	1M	C10	8n2	IC4	MN3007*
R11	10k	R36	10k	C11	470pF	Trimmer	
R12	470R	R37	220k	C12	1uF	VB	10k
R13	100k	R38	4k7	C13	33n	Pots	
R14	100k	R39	4k7	C14	3n3	DEPTH	100kB
R15	10k	R40	33R	C15	8n2	RATE	100kB
R16	10k	R42	4k7	C16	470pF		
R17	10k	R43	4k7	C17	33n		
R18	10k			C18	47pF		
R19	4k7			C19	47uF		
R20	56k			C20	100n		
R21	330k			C21	10n		
R22	10k			C22	100uF		
R23	10k			C23	47uF		
R24	10k			C24	100uF		
R25	10k						

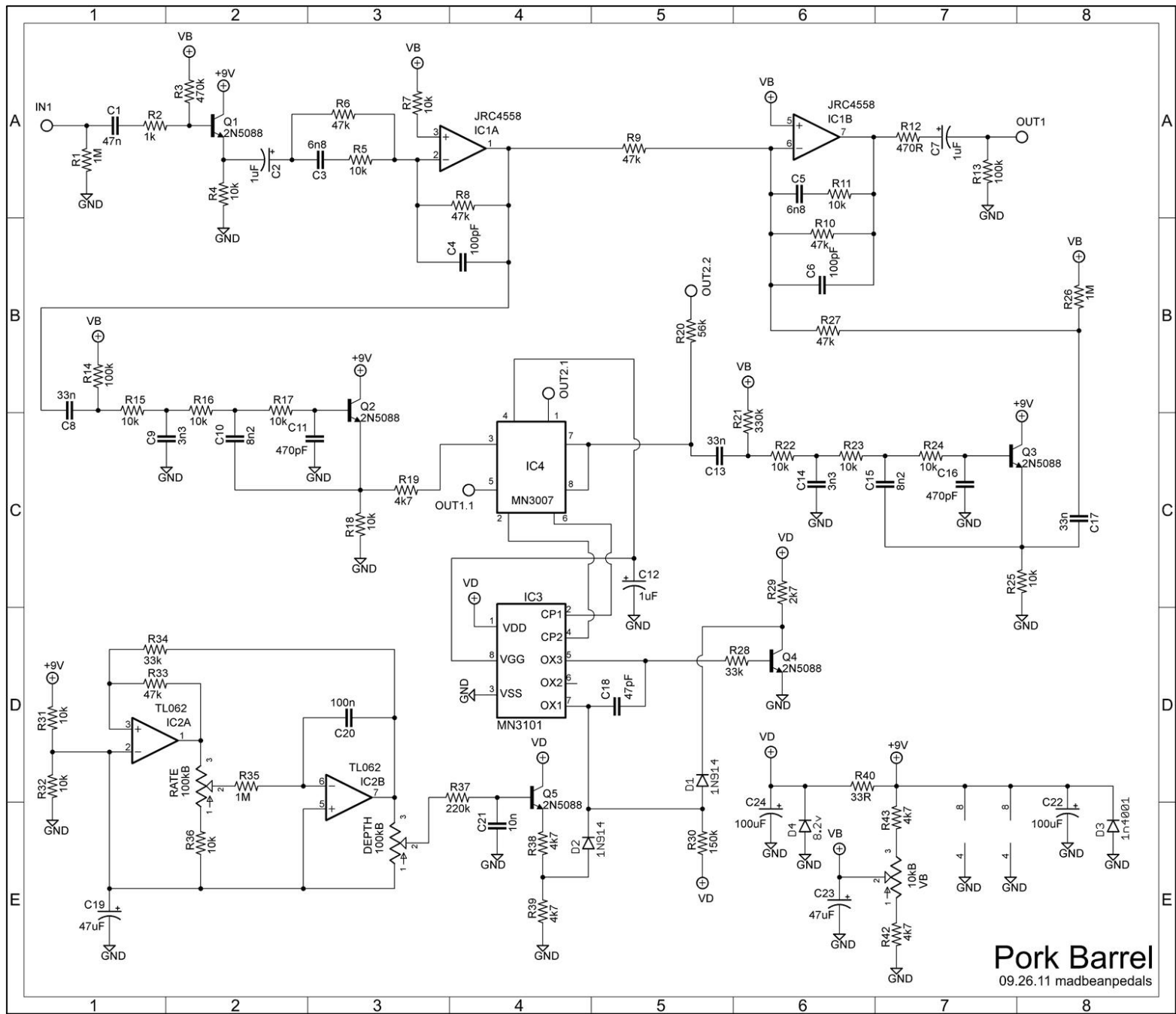

Pork Barrel
09.26.11 madbeanpedals

Notes

- **R1** is optional...the stock unit does not have a pull-down resistor. You most likely will NOT need to use it.
- Please refer to the stock madbeanpedals wiring diagram if you need guidance on wiring the board: http://www.madbeanpedals.com/tutorials/downloads/StandardWiring_MBP.pdf

Set-Up

MN3007 version: Omit **D4**, and use a MN3101 for **IC3**.

MN3207, v3207: Use **D4** to limit the BBD supply voltage to under 8.2v, and use either the MN3102 or v3102 for **IC3**.

Note that all of these BBDs and clocks are available from **smallbear** at the time of this writing. I have personally built these configurations: MN3007 with the MN3101, and the MN3207 with a v3102 clock. I have not used the MN3102 for the clock, but it should work exactly the same as the v3102.

There are two jumpers that need to be set depending on which BBD you are using. For the MN3007 the jumpers go one direction, and for the MN3207 or v3207 they go another way. Refer to the illustration below.

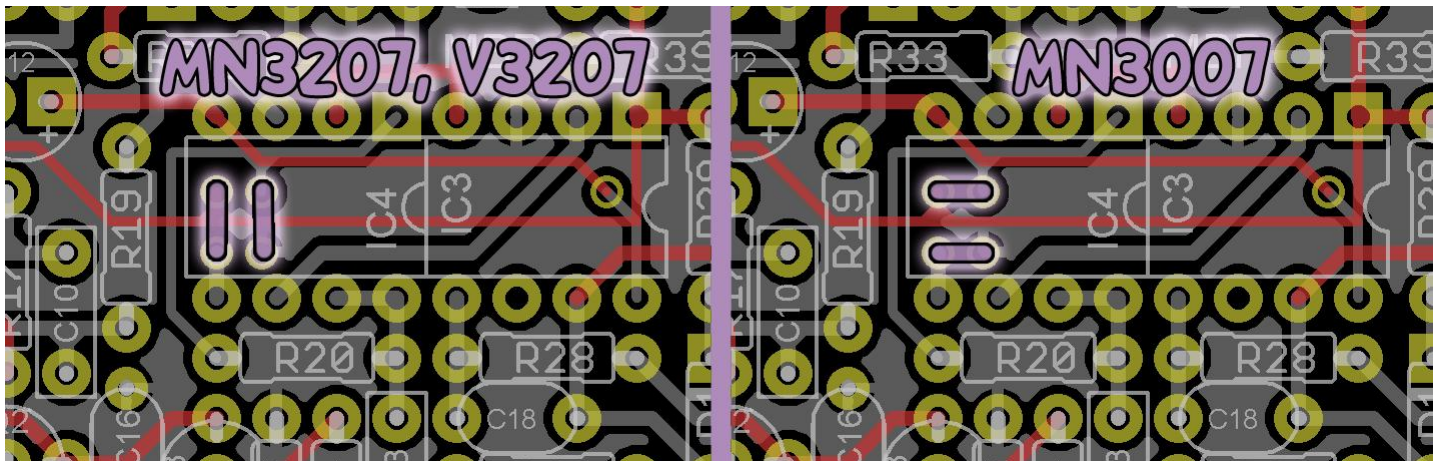

To bias the chorus effect, set the **VB** trimmer to its midpoint. Now adjust it left and right while playing your guitar until you get the chorus effect. You most likely will not need to make a fine adjustment. There is a wide range the chorus will work over.

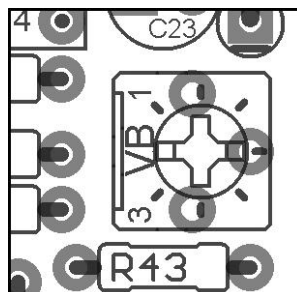

Mods

Two-for-one mod! Add an LFO indicator and get greater depth out of the chorus with one mod!!

Procedure: Omit **R39** from the PCB. Run a wire from the R39 pad on the right side of the PCB to one lead of a 22k resistor. Attach the other lead of the resistor to the positive lead of a High Brightness 3 or 5MM LED. The negative lead the LED goes to the 3PDT switch to toggle it on and off with bypass.

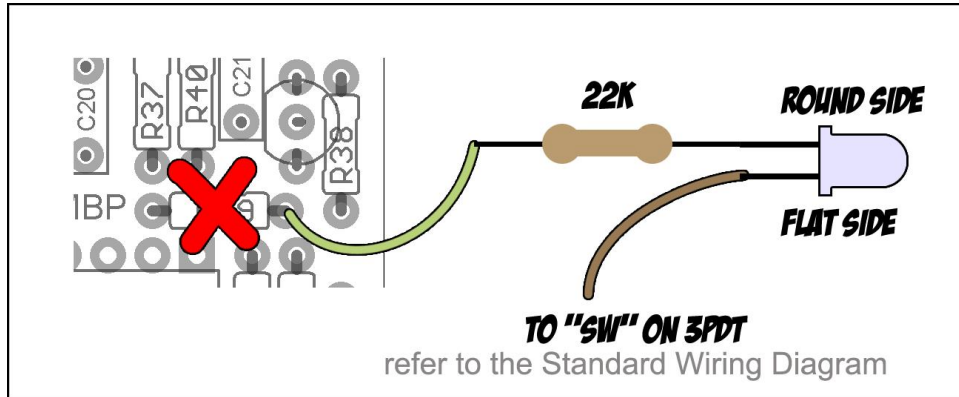

The LED will blink at the same rate as the LFO driver and will get brighter when the **Depth** pot is turned up. The use of a large resistor is key to increasing the overall depth of the chorus effect. You can use lower values, but keep it at 10k or above for the best effect!

1590B
Image size – 4.64" x 6.69"

This drilling diagram illustrates the hole locations for the PCB mounted pots. You will need to determine where you want to add your indicator LED.

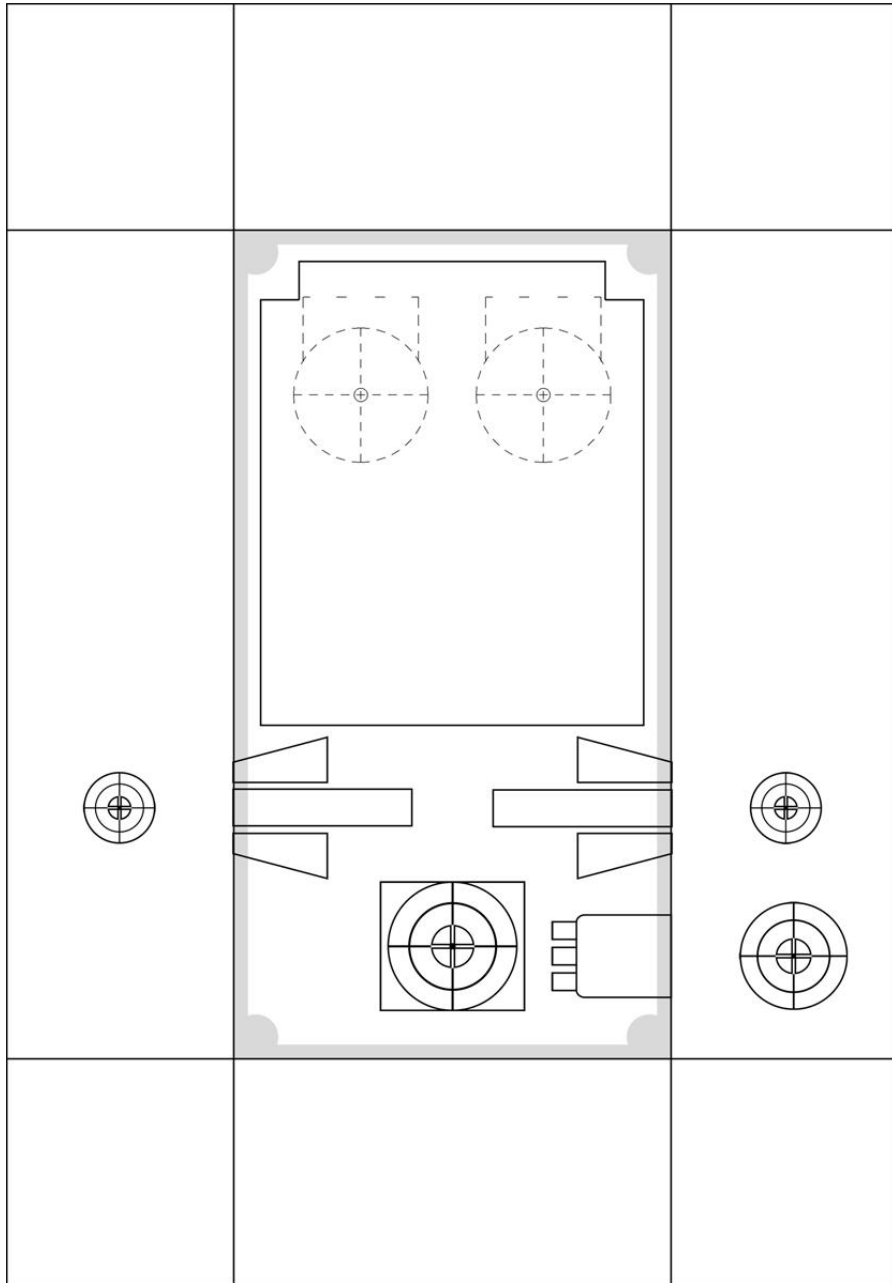

Terms of Use



The madbeanpedals effects projects and PCB products are available for non-commercial use to all DIY enthusiasts, hobby builders and pedal makers. They are not intended, nor should they be used, for commercial manufacturing. This means that the PCBs and information in the project documents should not be utilized in the context of professional pedal making. However, building the projects for yourself or your friends or making the occasional “one-off” for sale is entirely permissible. The sale of PCBs or kits using the included PCB artwork is strictly prohibited, however.

Please keep in mind that some of the madbeanpedals projects are based upon currently manufactured pedals. Using the projects or PCBs to make cheap knock-off pedal clones for sale on eBay is not only not cool, but potentially hazardous to your karma. While the vast majority of guitar effects circuits are not patented, many pedal manufacturers do hold trademarks over their products. Any attempt to infringe on a manufacturer’s trademark could be met with legal challenges, and madbeanpedals offers no warranty or guarantee against this, should you do so.

build.share.learn.