

QUADROVIBE

FX TYPE: VIBRATO

©2011 madbeanpedals · Release date: 07.1.11
revised 10.26 – see highlighted “notes” – Thanks, Paul!

The **Quadrovibe** is a unique Vibrato/Tremolo design that offers smooth, classic vibrato. Its origins can be found in the Tim Escobedo Wobbletron. Many changes and enhancements were made to the original circuit. These include the addition of an input JFET buffer, an output gain stage, and a switch to select either vibrato or tremolo. Lastly, the original Wobbletron LFO was swapped out for a true Univibe device that drives a miniature incandescent lamp. This is the reason for the Quadrovibe’s smoothness and gentle up and down ramp.

Controls

SPEED: Sets the overall rate of the LFO section.

VOL: Sets the amount of gain applied to the output stage.

INT: The intensity knob sets how much vibrato or tremolo is applied to the guitar signal.

SW1: Switches between vibrato and tremolo modes.

T1: This trimpot lets you match the tremolo output with the vibrato so there is no volume jump when switching between modes.

CHOP: This trimpot lets you fine-tune the intensity of the up/down ramp of the lamp.

GAIN: This trimpot sets the brightness of the LFO-driven lamp.

The Quadrovibe requires a charge pump to supply 18v to the lamp! Instructions are included for creating your own charge pump or utilizing the madbeanpedals Road Rage board.

A specific lamp has been designated in the Bill of Materials. It is the JKL 560-8099SB. This lamp is rated at 18v / 26mA. It was chosen for this project due to its size and for the ease of fit into a 1590B. The JKL is about half the size of the more common 7371, 14v lamp (used in many Univibe projects). You are welcome to use the 7371 however the added height of that lamp may prevent you from housing the Quadrovibe in a 1590B enclosure.

Smallbear has kindly agreed to carry the JKL lamp for this project!

Photocell

9203: <http://www.smallbearelec.com/Detail.bok?no=711>

NSL-7532 (alternate): <http://www.smallbearelec.com/Detail.bok?no=1003>

Lamp

JKL 560-8099SB: <http://www.smallbearelec.com/Detail.bok?no=1141>

100kC Dual Gang Pot

<http://www.smallbearelec.com/Detail.bok?no=1032>

Trimpots

<http://www.smallbearelec.com/Detail.bok?no=1101>

Bourns 3362P (alternate): http://www.mouser.com/Passive-Components/Trimmer-Resistors/Trimmer-Resistors-Single-Turn/_/N-76qcw?Keyword=bourns+3362P&FS=True

Layout Diagram

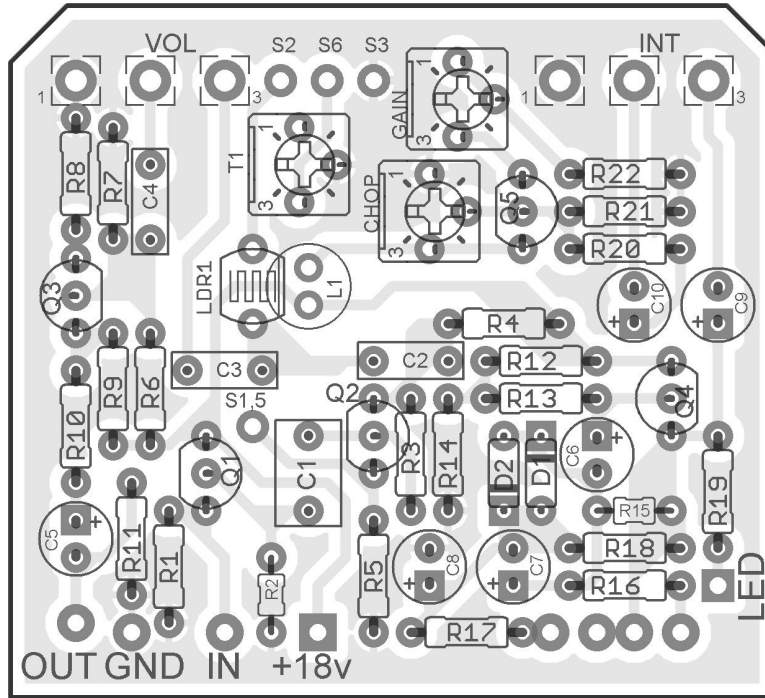

Bill of Materials

Resistors		Caps		Trimpots	
R1	1M	C1	1uF	T1	20k
R2	10k	C2	220n	CHOP	100k
R3	4M7	C3	220n	GAIN	500R
R4	10k	C4	100n	Pots	
R5	6k8	C5	10uF	SPEED	Dual 100kC
R6	470k	C6	1uF	VOL	100kB
R7	100k	C7	1uF	INT	100kB
R8	2k	C8	1uF	Charge Pump	
R9	10k	C9	10uF	D1	1N4001
R10	470R	C10	10uF	D2, D3	1N5817
R11	33k	Diodes		C1	100uF
R12	3k3	D1, D2	1n914	C2, C3	10uF
R13	2M2	Transistors		IC	LT1054
R14	4k7	Q1	J201		
R15	220k	Q2, Q3	BC549C		
R16	2k2	Q4, Q5	MPSA13		
R17	2k2	Lamp			
R18	220k	L1	560-8099SB		
R19	2k2	LDR1	9203		
R20	4k7	Switch			
R21	47k	SW1	DPDT		
R22	47R				

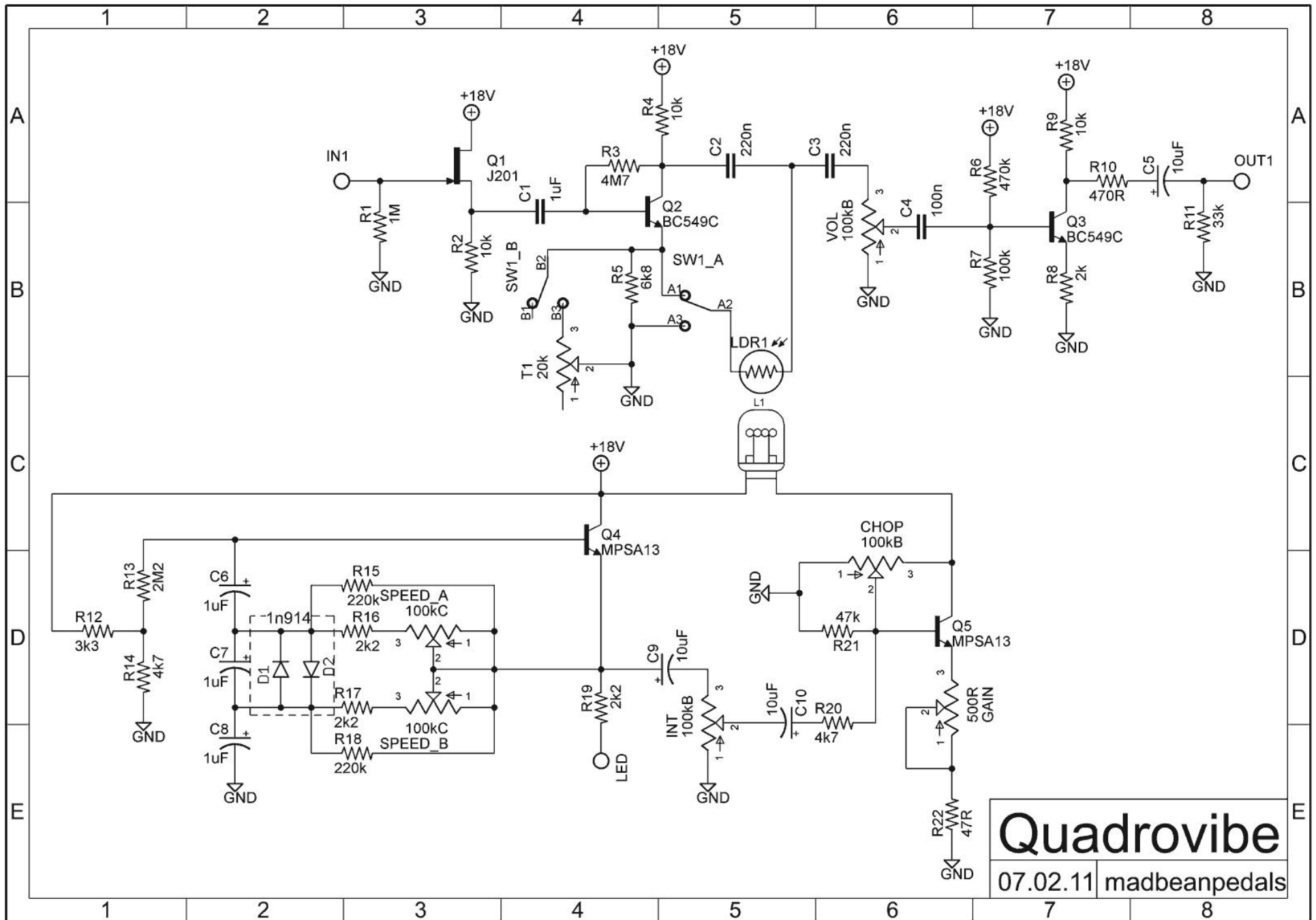

Quadrovibe
 07.02.11 | madbeanpedals

** CHOOSING A CHARGE PUMP **

The Quadrovibe requires 18v to operate the lamp. While you can use an 18v adaptor, a charge pump is preferred due to the absence of any power supply filtering or polarity protection on the Quadrovibe board (this was done to preserve space on the PCB).

18v charge pump with an LT1054

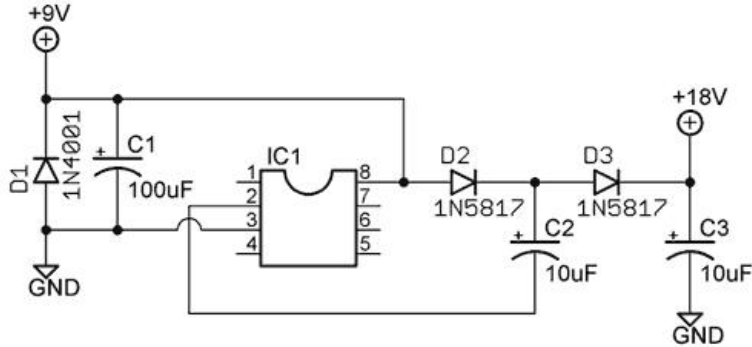

The LT1054 is used due to its higher current output. **D2** and **D3** are designated as 1N5817 for minimal voltage drop. Note that when using an LT1054, pins 1 and 8 of the IC are not connected.

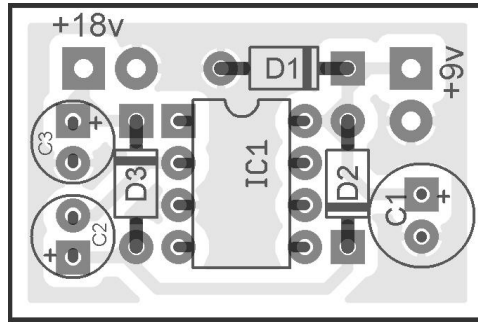

Road Rage

You can also use a madbeanpedals **Road Rage** board if you do not want to make your own charge pump. The **Road Rage** has pins 1&8 connected via a trace. This means you will need to either use a socket, and cut out the tab on pin1 or snip off pin1 on the actual LT1054. Do not leave pins 1&8 connected or it may fail to operate correctly. The component numbering is a little different on the RR than the schematic above, so values are shown instead. Leave off the components in the gray boxes...they are not needed for this type of operation.

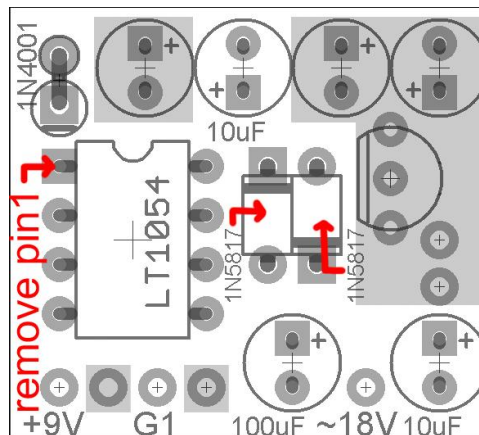

2.05"W x .185"H

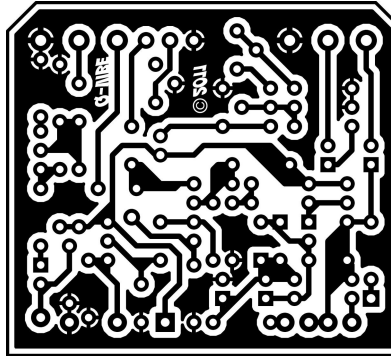

1.13"W x .76"H

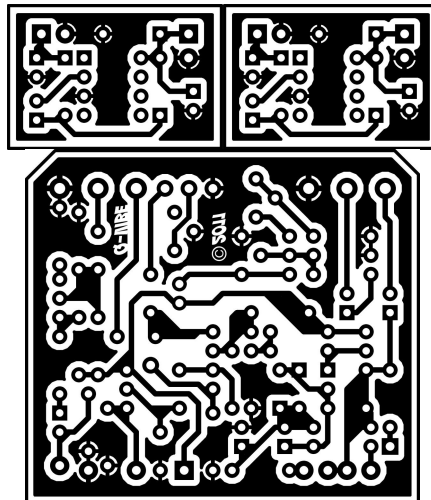
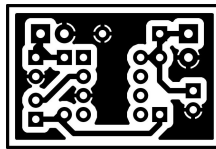

WIRING DIAGRAM

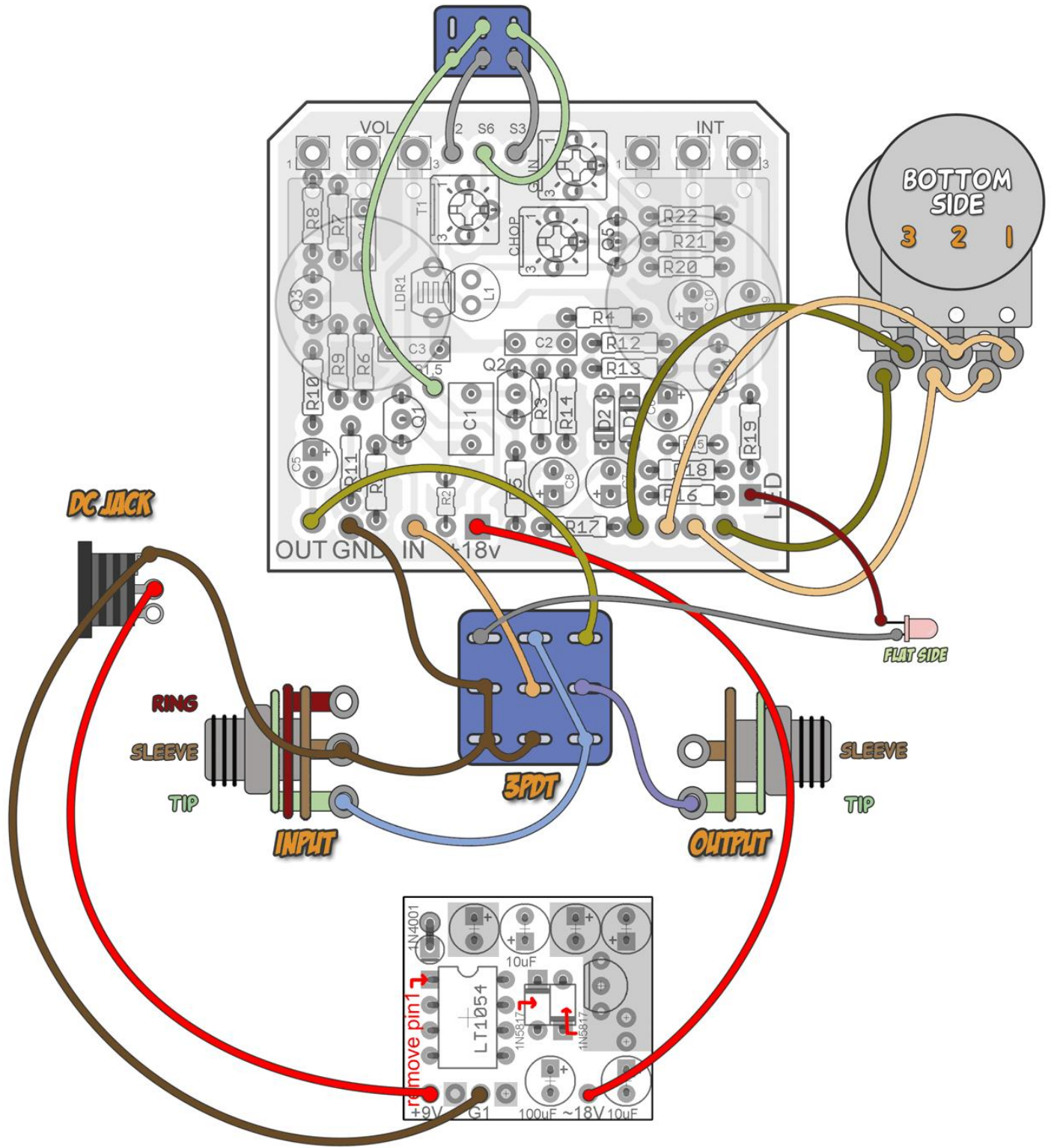

1590B
4.64" x 6.69"

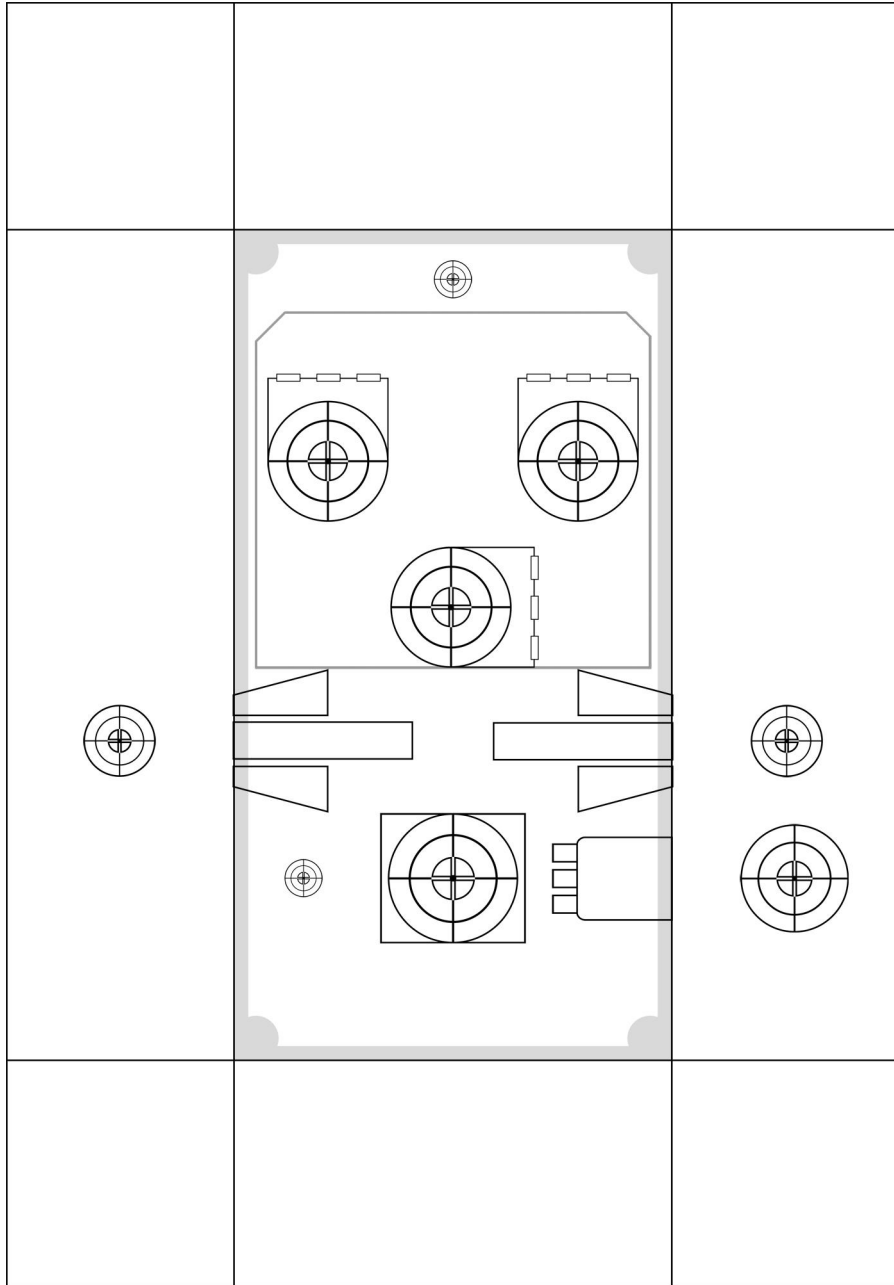

Notes

- The LED hookup allows you to have your indicator flash on and off at the rate set by the Speed knob. When the effect is off, the lamp is partially disconnected from the LFO. The advantage of this system is that not only do you get a rate indicator, but it also helps preserve the life of the lamp by reducing the amount that it is driven when the effect is bypassed. The disadvantage is that there will be a slight delay until the lamp reaches full brightness when the effect is switched on. If you wish to eliminate this delay, jumper R14 directly to ground, and set up a normal LED indicator (be sure to use a current limiting resistor) with your 3PDT switch.
- LDR/Lamp: Mount your photocell so that the flat portion points directly to the lamp. When you first set the trimpots, do it in low light and watch how the lamp responds to changes. Once you are satisfied with your settings, you can use heat shrink around the lamp/photocell if you wish to enclose them for light shielding. You should leave the top portion of the heat shrink open, though, so you can make visual changes to the settings in the future.

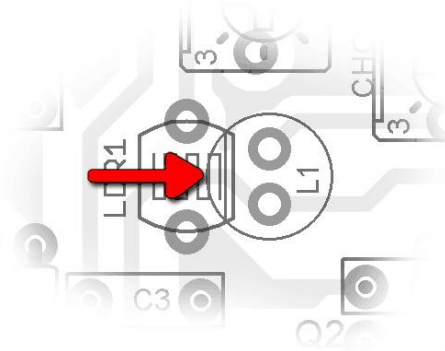

- Sockets for **R16** and **R17** are strongly recommended. The value of these resistors sets the maximum rate of the **Speed** knob. You may find the indicated value of 2k2 in the BOM too high or too low, depending on your preference. Note that too low of a value for **R16/17** may cause the lamp to “lock up” temporarily. If this happens, just turn the speed knob down and the lamp will re-start. Experiment with different values there (1k8 – 4k7) until you find what’s right for you.
- Setting the trimpots is very simple. Start with the **GAIN** fully counter-clockwise and the **CHOP** a little less than half-way. In Vibrato mode, slowly turn the **GAIN** up until the lamp starts to fire. Set the **GAIN** for the maximum brightness you want (this determines how strong the vibrato is). Now set the **CHOP** trimpot to control how quickly the lamp shuts on and off. You will most likely spend some time playing with both of these trimpots until you get exactly the sound you want. After you are satisfied with how the lamp is behaving, switch to Tremolo mode and adjust **T1** so that the Tremolo volume matches the Vibrato volume. Be careful when setting the **GAIN** and **CHOP** close to maximum as this might cause the lamp to fail via excessive brightness.
- You can use PCB mounted pots for the **VOL** and **INT** controls:
<http://www.smallbearelec.com/Detail.bok?no=692>



Terms of Use



The madbeanpedals effects projects and PCB products are available for non-commercial use to all DIY enthusiasts, hobby builders and pedal makers. They are not intended, nor should they be used, for commercial manufacturing. This means that the PCBs and information in the project documents should not be utilized in the context of professional pedal making. However, building the projects for yourself or your friends or making the occasional “one-off” for sale is entirely permissible. The sale of PCBs or kits using the included PCB artwork is strictly prohibited, however.

Please keep in mind that some of the madbeanpedals projects are based upon currently manufactured pedals. Using the projects or PCBs to make cheap knock-off pedal clones for sale on eBay is not only not cool, but potentially hazardous to your karma. While the vast majority of guitar effects circuits are not patented, many pedal manufacturers do hold trademarks over their products. Any attempt to infringe on a manufacturer’s trademark could be met with legal challenges, and madbeanpedals offers no warranty or guarantee against this, should you do so.

build.share.learn.