

# Collosalus24

F X Type: **MODULATION**

Build Level: Advanced

Based On: MXR® 117™

Last Updated: July 18, 2024 11:45 AM

© 2024 [madbeanpedals](#)



## Overview

The 2024 version of the Collosalus has no circuit changes and minor layout adjustments. A new bypass board is included with purchase.

The Collosalus first arrived in 2014. It was based on the work done on DIYSB to convert the vintage SAD1024 MXR 117 to the MN3007 BBD. The project had a great run, was popular and then was discontinued around 2018 for some reason I cannot remember (I think because I had planned on doing a bunch of new flangers at the time). Coming back to it in 2022, I decided to do a total redesign of the project and schematic redraw to make it more legible and to make a better, cleaner build.

The 2022 version does not have a charge pump from the previous version and operates on a standard 18v 100mA power supply instead. This was to address issues with noise when using a charge pump powered by 9v supply. Some builders had no problems with 9v, while others had better results using 12v with the on-board charge pump. Making the default power 18v seems the best way to eliminate any potential noise issues. I did test the 2022 version with a 9v powered charge pump and it seemed to work okay. So, that option is there if 9v is a must for you.

The PCB has also been converted to a 4-layer layout. This helps reduce noise and greatly improves the signal routing between audio, power, clock and LFO.

## Controls

- **RATE:** Modulation (flanger) speed.
- **WIDTH:** Depth control.
- **MANUAL:** Creates fixed resonant peaks at different frequencies as it is turned up and with WIDTH CCW. It will interact with WIDTH until that control is turned above 1/2 up or so.
- **REGEN:** Flanger feedback control.
- **BIAS:** This trimmer is used to fix the bias input of the MN3007 for cleanest delayed signal (see notes).
- **LVL:** This trimmer is set in tandem with the REGEN control to prevent oscillation (see notes).
- **CLOCK:** This trimmer is used to set the clock range for the BBD (see notes).

**Terms of Use:** You are free to use purchased Collosalus24 circuit boards for both DIY and small commercial operations. You may not offer Collosalus24 PCBs for resale or as part of a "kit" in a commercial fashion. Peer to peer re-sale is fine, though.

**Technical assistance** for is available via the [madbeanpedals forum](#). Please go there rather than emailing me for personal assistance. This is because (1) I'm not always available to respond via email in a timely and continuous manner, and (2) posting technical problems and solutions in the forum creates a record from which other members may benefit.

All copyrights and registered trademarks are property of their original owners. Any mention of trademarked or intellectual properties in this documents is purely for comparative purposes.

# Parts Layout

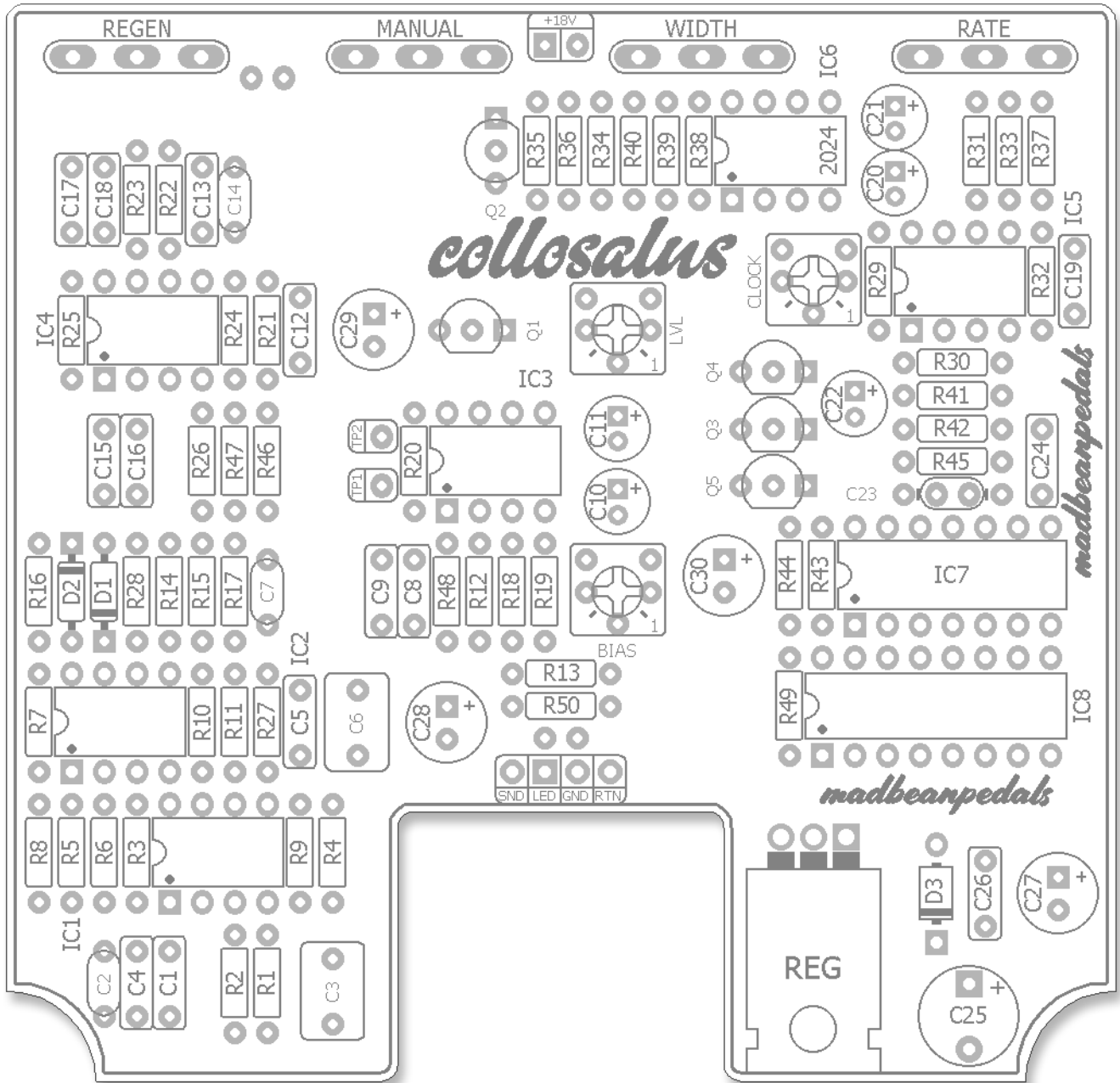

# Component Values

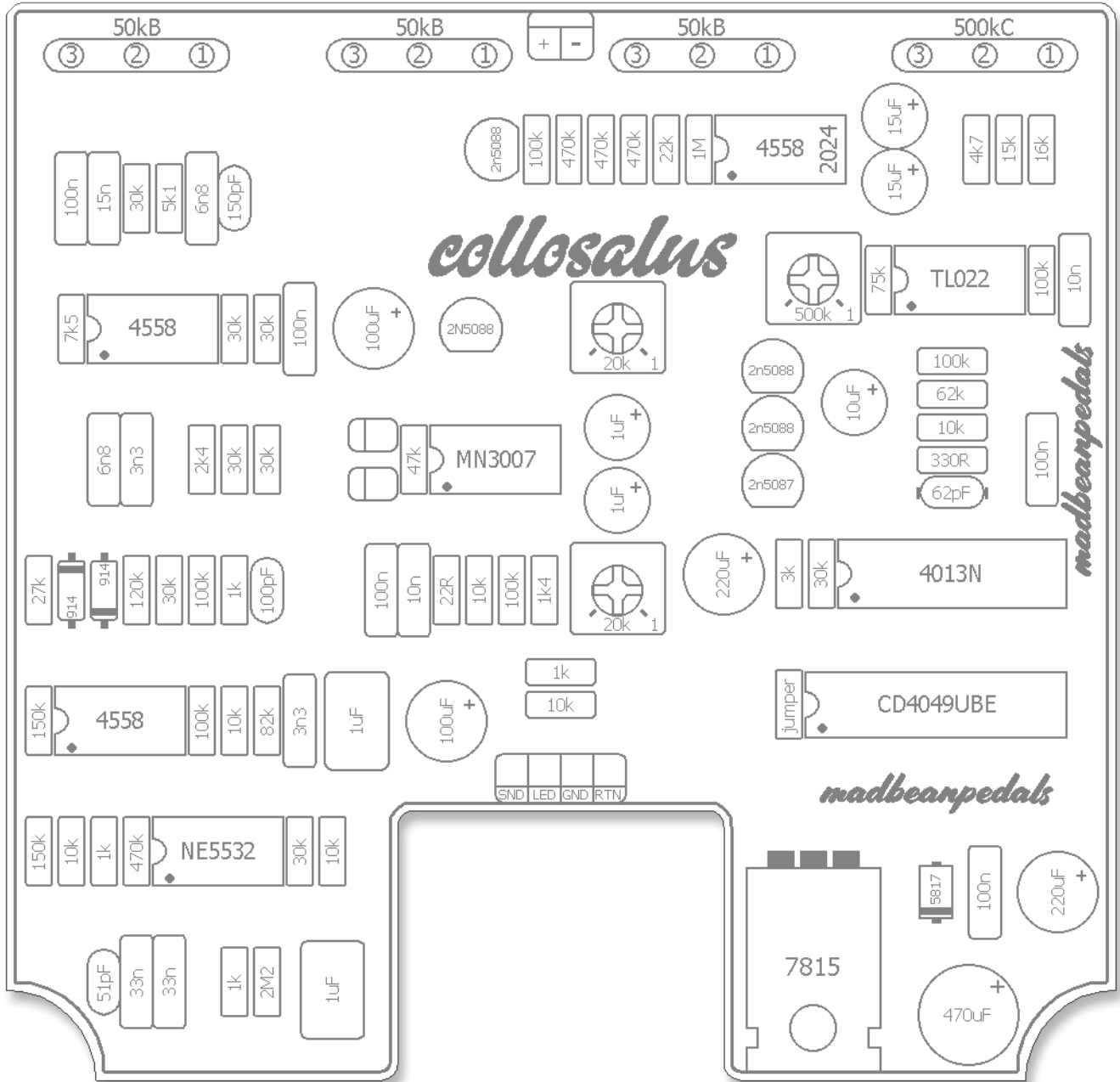

# Trace Layout - Outer Traces

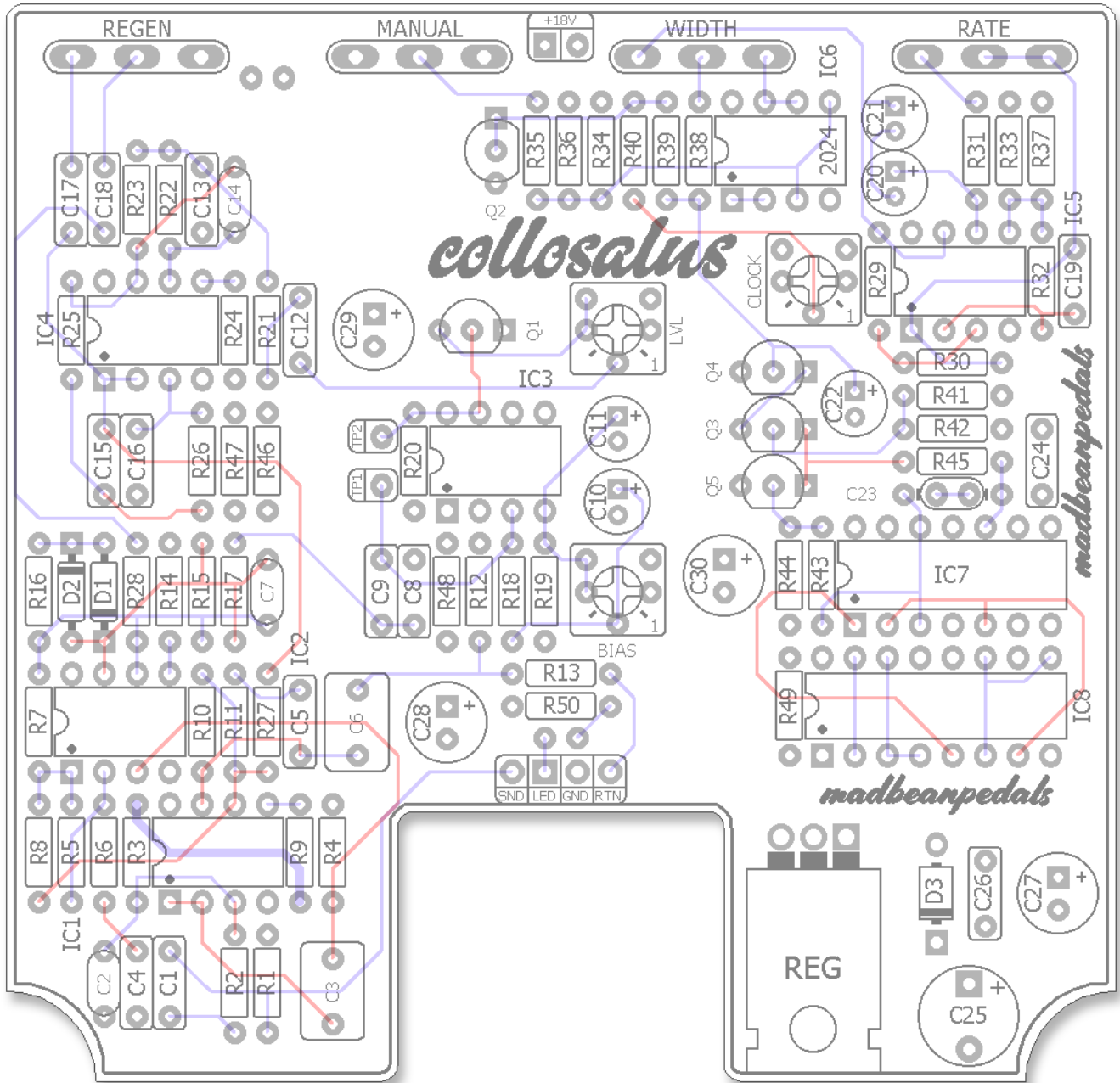

# Trace Layout - Inner Traces

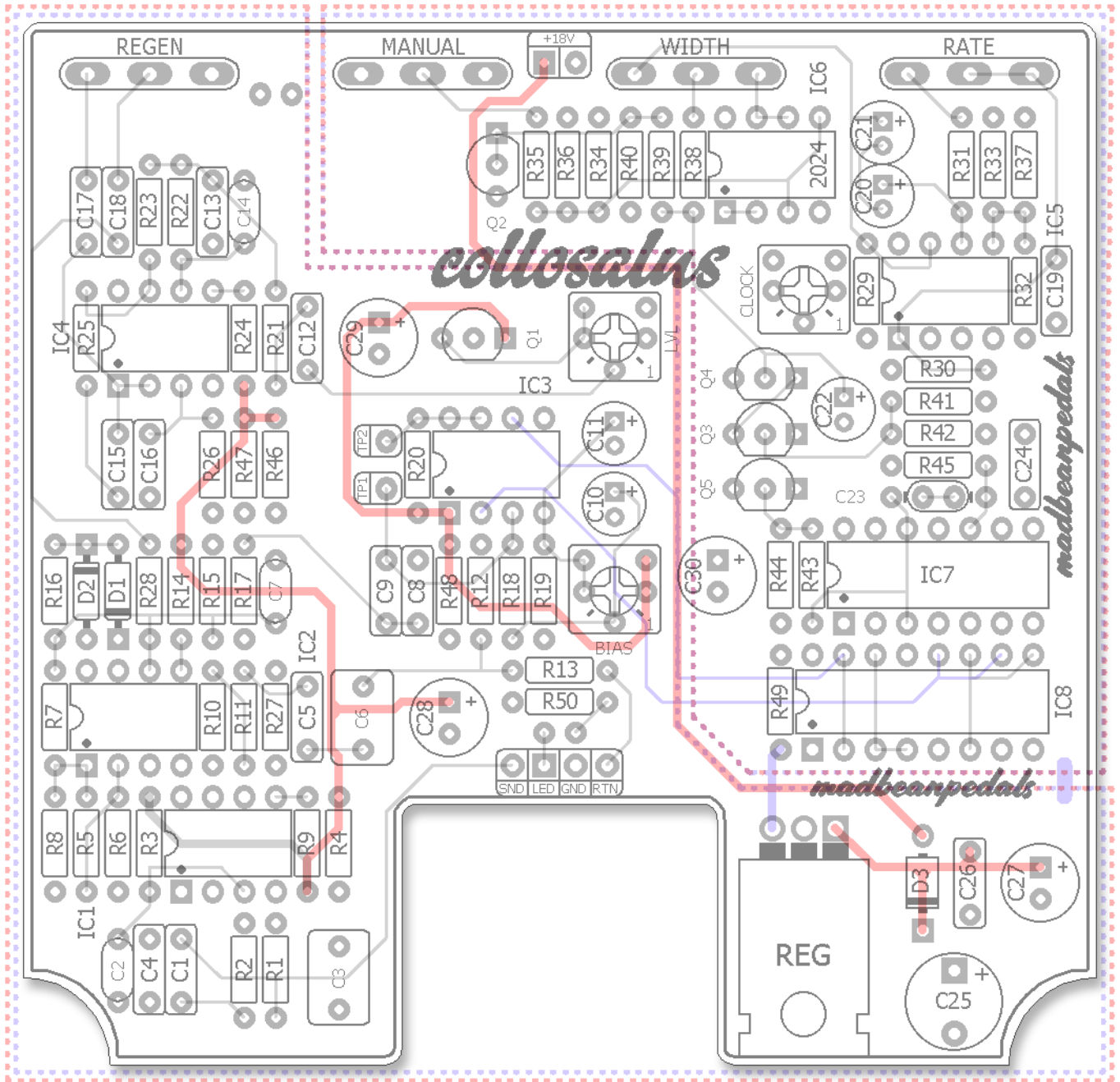

## Wiring

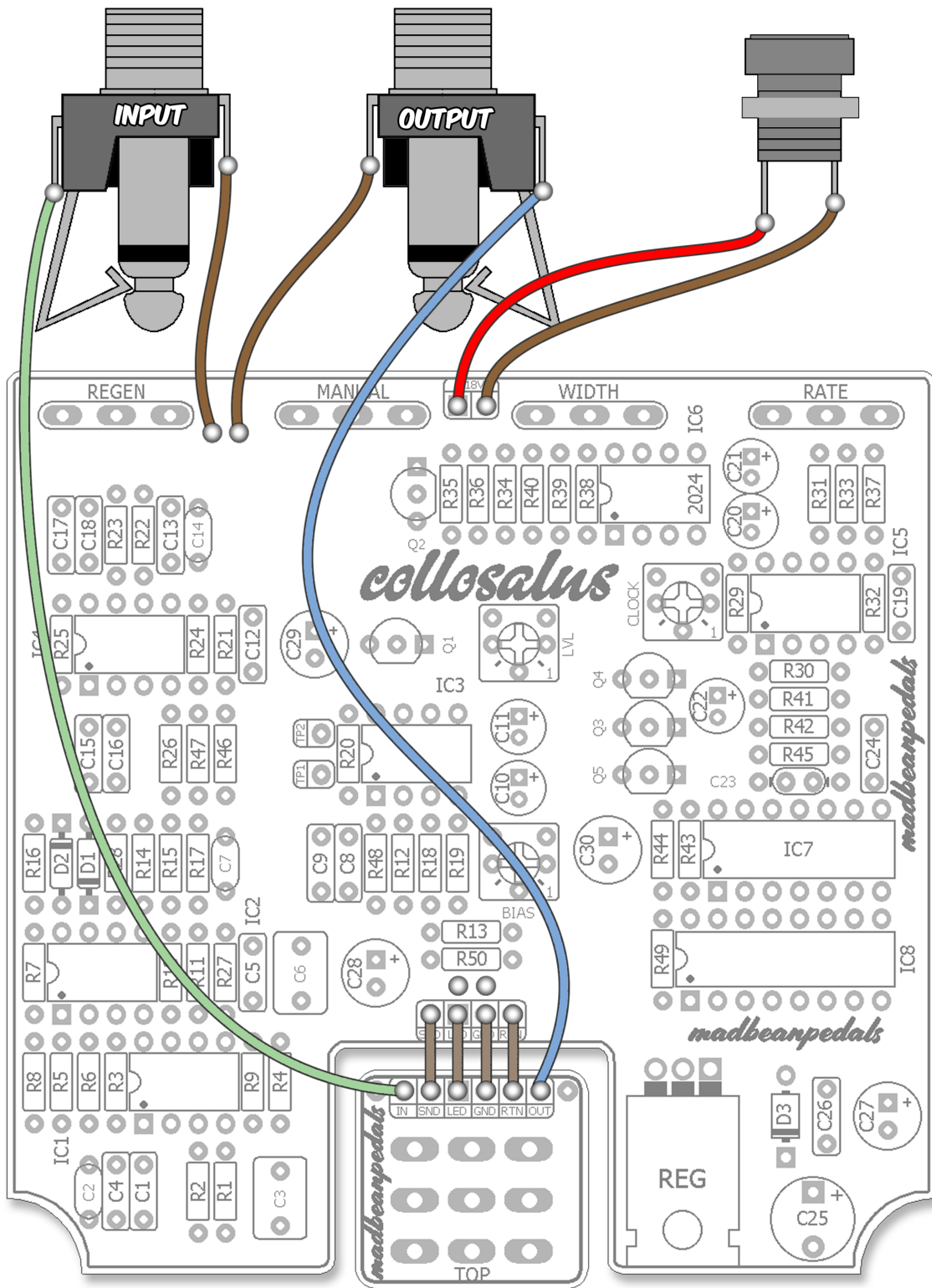

The 2024 version comes with a bypass board. The bypass LED is soldered beneath the Collosalus PCB just above the bypass connections.

**B.O.M.**

Resistors		Resistors		Caps		Diodes	
R1	2M2	R31	4k7	C1	33n	D1	1n914
R2	1k	R32	100k	C2	51pF	D2	1n914
R3	470k	R33	15k	C3	1uF	D3	1n5817
R4	10k	R34	470k	C4	33n	<b>Transistors</b>	
R5	10k	R35	100k	C5	3n3	Q1	2N5088
R6	1k	R36	470k	C6	1uF	Q2	2n5088
R7	150k	R37	16k	C7	100pF	Q3	2n5088
R8	150k	R38	1M	C8	10n	Q4	2n5088
R9	30k	R39	22k	C9	100n	Q5	2n5087
R10	100k	R40	470k	C10	1uF	<b>Regulators</b>	
R11	10k	R41	62k	C11	1uF	REG	LM7815
R12	10k	R42	10k	C12	100n	<b>ICs</b>	
R13	1k	R43	30k	C13	6n8	IC1	NE5532
R14	30k	R44	3k	C14	150pF	IC2	4558
R15	100k	R45	330R	C15	6n8	IC3	MN3007
R16	27k	R46	30k	C16	3n3	IC4	4558
R17	1k	R47	30k	C17	100n	IC5	TL022
R18	100k	R48	22R	C18	15n	IC6	4558
R19	1k4	R49	jumper	C19	10n	IC7	CD4013
R20	47k	R50	10k	C20	15uF	IC8	CD4049U
R21	30k			C21	15uF	<b>Trimmers</b>	
R22	5k1			C22	10uF	BIAS	20k
R23	30k			C23	62pF	CLOCK	500k
R24	30k			C24	100n	LVL	20k
R25	7k5			C25	470uF	<b>Pots</b>	
R26	2k4			C26	100n	MANUAL	50kB
R27	82k			C27	220uF	REGEN	50kB
R28	120k			C28	100uF	WIDTH	50kB
R29	75k			C29	100uF	RATE	500kC
R30	100k			C30	220uF		

## Shopping List

Value	QTY	Type	Rating	Value	QTY	Type	Rating
22R	1	Metal / Carbon Film	1/4W	1uF	2	Electrolytic	25v
330R	1	Metal / Carbon Film	1/4W	10uF	1	Electrolytic	25v
1k	4	Metal / Carbon Film	1/4W	15uF	2	Electrolytic	25v
1k4	1	Metal / Carbon Film	1/4W	100uF	2	Electrolytic	25v
2k4	1	Metal / Carbon Film	1/4W	220uF	2	Electrolytic	25v
3k	1	Metal / Carbon Film	1/4W	470uF	1	Electrolytic	25v
4k7	1	Metal / Carbon Film	1/4W	1n914	2		
5k1	1	Metal / Carbon Film	1/4W	1n5817	1		
7k5	1	Metal / Carbon Film	1/4W	2n5088	4		
10k	6	Metal / Carbon Film	1/4W	2n5087	1		
15k	1	Metal / Carbon Film	1/4W	LM7815	1		
16k	1	Metal / Carbon Film	1/4W	NE5532	1		
22k	1	Metal / Carbon Film	1/4W	4558	3		
27k	1	Metal / Carbon Film	1/4W	MN3007	1		
30k	8	Metal / Carbon Film	1/4W	TL022	1	or, LM1458	
47k	1	Metal / Carbon Film	1/4W	CD4013	1		
62k	1	Metal / Carbon Film	1/4W	CD4049	1	UBE - unbuffered version	
75k	1	Metal / Carbon Film	1/4W	20k	2	Bourns 3362p or 6mm	
82k	1	Metal / Carbon Film	1/4W	500k	1	Bourns 3362p or 6mm	
100k	6	Metal / Carbon Film	1/4W	50kB	3	PCB Right Angle	16mm
120k	1	Metal / Carbon Film	1/4W	500kC	1	PCB Right Angle	16mm
150k	2	Metal / Carbon Film	1/4W				
470k	4	Metal / Carbon Film	1/4W				
1M	1	Metal / Carbon Film	1/4W				
2M2	1	Metal / Carbon Film	1/4W				
51pF	1	Ceramic / MLCC	25v min.				
62pF	1	Ceramic / MLCC	25v min.				
100pF	1	Ceramic / MLCC	25v min.				
150pF	1	Ceramic / MLCC	25v min.				
3n3	2	Film	25v min.				
6n8	2	Film	25v min.				
10n	2	Film	25v min.				
15n	1	Film	25v min.				
33n	2	Film	25v min.				
100n	5	Film	25v min.				
1uF	2	Film	25v min.				

### Additional Hardware

- (1) 1590BB enclosure
- (2) 1/4" mono jacks
- (1) Slim 2.1mm DC jack
- (1) Standard 3PDT footswitch
- (1) 5mm LED

## Build Notes

You can use either TL022 or LM1458 for IC5 (LFO). I do not recommend the TL062 or the 4558 (they do not perform as well as the other two). I personally prefer the LM1458 so that's my recommendation.

R49 should be jumpered on the PCB. I added this in the hopes it might reduce any potential thumping/clicking from the LFO. While this is often the case for many LFO driven circuits, in this one it has the opposite effect: it made the LFO perform much worse and created a thump. It just goes to show there is never a "one solution fits all" when it comes to guitar pedals.

The regulator does not absolutely have to be an LM7815/L7815 TO-220. The current draw is low enough that an LM78L15 TO-92 style regulator should work. But, I recommend sticking with the former. The cost difference is negligible and there's plenty of space on the layout for the larger one. Note that the TO-92 LM78L15 has the opposite pinout as the one used in the build.

I decided to do a different wiring and I/O setup for this build. It's less tidy than my normal template. The reason is to keep all the audio wiring as far away from the LFO as possible. Take a look at my build at the end of the doc to see how I placed the wiring in the enclosure. I have zero noise/thumping in my build. If you replicate what I did then neither should you.

As far as testing the build before calibration, I recommend taking a methodical approach. When I build very complicated circuits I don't rush right to testing them on my prototyping rig. Instead, I work through the testing in stages. The first step is to leave ALL ICs off and power up. Next verify that each IC socket is receiving the correct DC. For example, IC1, 2, 4, 5 pin8 on each socket reads about 15v. IC3 pin1 is slightly less than 15v (VD on the schematic). You get the idea. Then power down, and load the audio ICs (except for the MN3007) and power back up. So, that would be IC1, 2, and 4. Check pin8 again on each and verify you have about the same reading as before. It might go down very slightly with the load, but not too far. If the supply voltage goes way down then you have a problem like a bad chip or maybe something else. So long as everything checks out, you can power down and load more or all ICs, then check the DC supply again. It takes longer to describe than to actually do and removes a lot of guesswork if there is a problem.

## Calibration

Before we start, take a look at how I have C23 set up. This is the clocking cap for the CD4013. That cap is listed as 62pF but quite possibly the final value was dialed in somewhat on the vintage units. 62pF may not be optimal for our build, and it's certainly not a typical value, so I have provided a little more control on the Collosalus PCB.

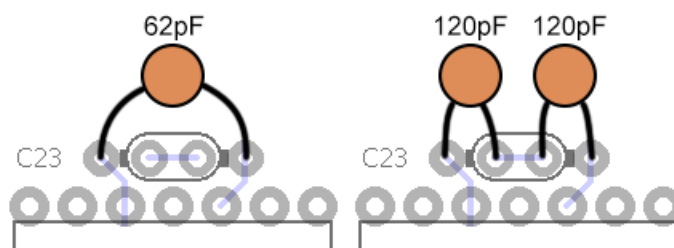

## Build Notes

We have two ways to populate C23: 1) use a single 62pF cap spread across the four pads for C23, or 2) use two 120pF caps in series to approximate the 62pF value. And, if we need some different value cap to get the optimal clock range, we could do the same for the new value should it fall in between conventional ones (for example, on my 2015 version build I used a single 47pF with no issue). Will it be necessary? Probably not, but the option is there. I recommend socketing all four pads of the C23 footprint and just stick in a 62pF or two 120pF to begin the calibration procedure.

For reference, the 117 is reported to have a clock range of about 30-50kHz min to around 1MHz max. Decreasing the value of C23 will push clock range further up the scale. Using the Biasing procedure below I dialed my build in by ear then measured the clock range using the slowest Rate setting. I measured the range of my build from about 24kHz to 600kHz. So, it's lower than expected but still sounded great to me. I may go back and try a smaller value cap for C23 at some point, though.

You can find some helpful info in these threads:

<https://www.diytompboxes.com/smfforum/index.php?topic=93223.0>

<https://www.diytompboxes.com/smfforum/index.php?topic=78741.0>

## Biasing

Set Manual fully counter-clockwise, Width and Regen about  $\frac{1}{2}$  up, and Sweep about  $\frac{1}{4}$  up.

Set the CLOCK and LVL trimmers  $\frac{1}{2}$  up and the BIAS full CCW.

Apply power to the effect.

Using an audio probe, check TP1 on the Collosalus PCB to verify that you signal at the input of IC3 (pin 3). If you have no audio, then you need to work backwards through the PCB using the schematic as reference to determine where you have lost signal. Debug as necessary.

Now audio probe TP2 on the PCB. This is the output of the IC3 (pins 7 and 8).

Adjust the BIAS trimmer clockwise until you hear output on TP2. Leave the BIAS trimmer at the position that produces the cleanest output signal possible. You should hear some flanging effect at this point.

Now adjust the CLOCK trimmer left and right. In the left-most position, the bottom of the flanger sweep will tend to flatten out at the most extreme. As you turn the trimmer up, the range of the sweep will decrease and become more shallow. Set this trimmer at the position where you have the most depth and about equal amounts of rise and fall in the flanger sweep. I found this to be about  $\frac{1}{4}$  up on the trimmer. You can alter the RATE control to check how the flanger responds at different speeds and adjust the CLOCK trim accordingly.

Set the Regen fully clockwise. Now adjust the FDBK trimmer to increase the maximum amount of feedback you can achieve before it begins to self-oscillate. You will hear this as a loud "sprising" at the bottom of the flanger's sweep. Back off the trimmer from this position until the "sprising" goes away.

## Circuit Voltages

IC1 NE5532		IC5 LM1458		IC8 CD4049UBE	
1	6.99	1	varies	1	15.28
2	6.99	2	~7.8	2	7.63
3	6.7	3	varies	3	7.63
4	0	4	0	4	7.63
5	7.58	5	~7.8	5	7.63
6	7.58	6	~7.8	6	7.63
7	7.64	7	varies	7	7.63
8	15.28	8	15.28	8	0
IC2 4558		IC6 4558		9	7.63
1	7.62	1	varies	10	7.63
2	7.62	2	~4.3	11	7.63
3	7.61	3	~4.3	12	7.63
4	0	4	0	13	~4.9
5	7.58	5	2.26	14	7.63
6	7.62	6	2.28	15	7.63
7	7.39	7	2.28	16	~11.4
8	15.28	8	15.28	Q1 2n5088	
IC3 MN3007		IC7 CD4013BE		C	15.28
1	15.25	1	~7.63	B	7.69
2	7.64	2	7.63	E	7.12
3	8.5	3	15.25	Q2 2n5088	
4	1.05	4	0	C	~420mV
5	0	5	4.63	B	~420mV
6	7.64	6	0	E	0
7	7.6	7	0	Q3 2n5088	
8	7.6	8	15.27	C	11.43
IC4 4558		9	15.27	B	2.15
1	7.61	10	11.4	E	1.99
2	7.61	11	15.27	Q4 2n5088	
3	7.6	12	15.25	C	1.99
4	0	13	15.27	B	485mV
5	7.59	14	15.27	E	0
6	7.62	REG LM7815		Q5 2n5087	
7	7.62	I	17.96	C	11.43
8	15.28	G	0	B	15.28
		O	15.28	E	15.28

- Dunlop 18v 1A power supply (18.24v output w/ no load)
- Current Draw: ~35mA
- Testing Conditions: All knobs CCW
- Some results will vary depending on trimmer settings.

## Drill Template

Coordinates are denoted in (X,Y), drill size format starting from the center (0,0) location of the enclosure.

Tayda drill link: [https://drill.taydakits.com/box-designs/new?public\\_key=ZG03ZVRrdTNQaHBVY0d6WnVYM3pndz09Cg==](https://drill.taydakits.com/box-designs/new?public_key=ZG03ZVRrdTNQaHBVY0d6WnVYM3pndz09Cg==)

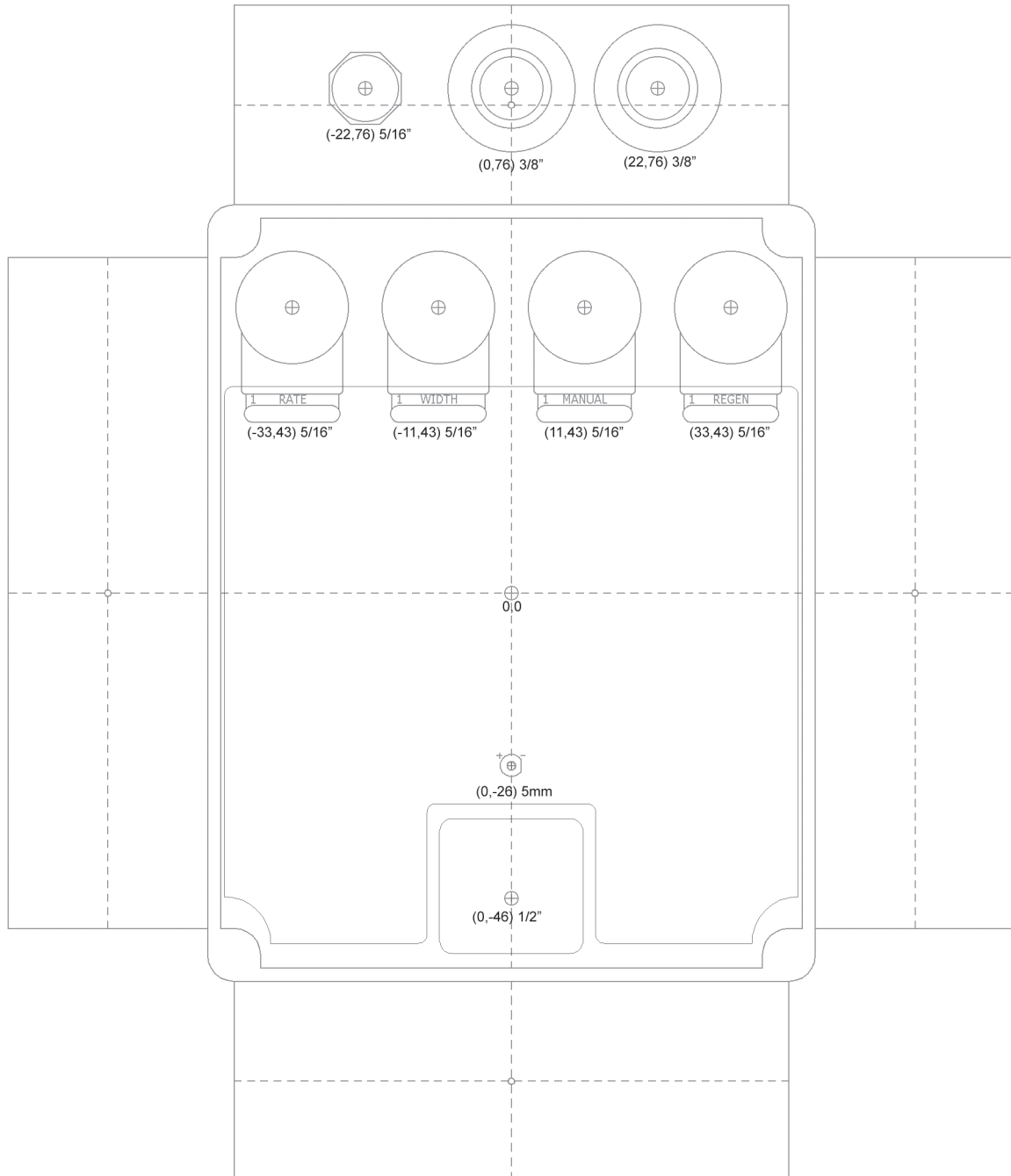

### Hardware

1590BB enclosure  
1/4" mono jacks  
Slim 2.1mm DC jack  
Standard 3PDT footswitch  
5mm LED

**NOTE: Different 1/4" and DC jack styles may require different sized drill holes.**

**Build Pic**

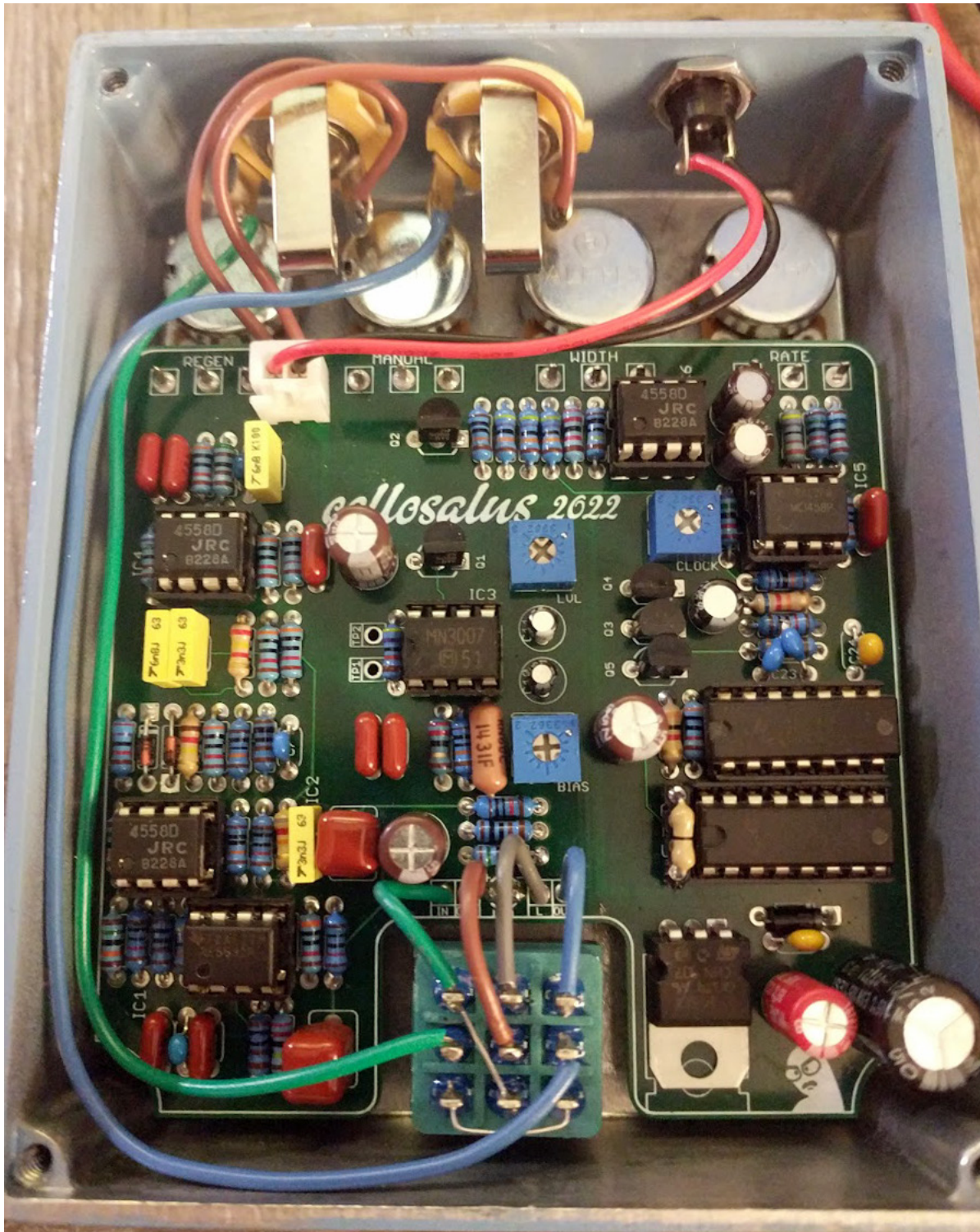

Previous version build.

# Schematic

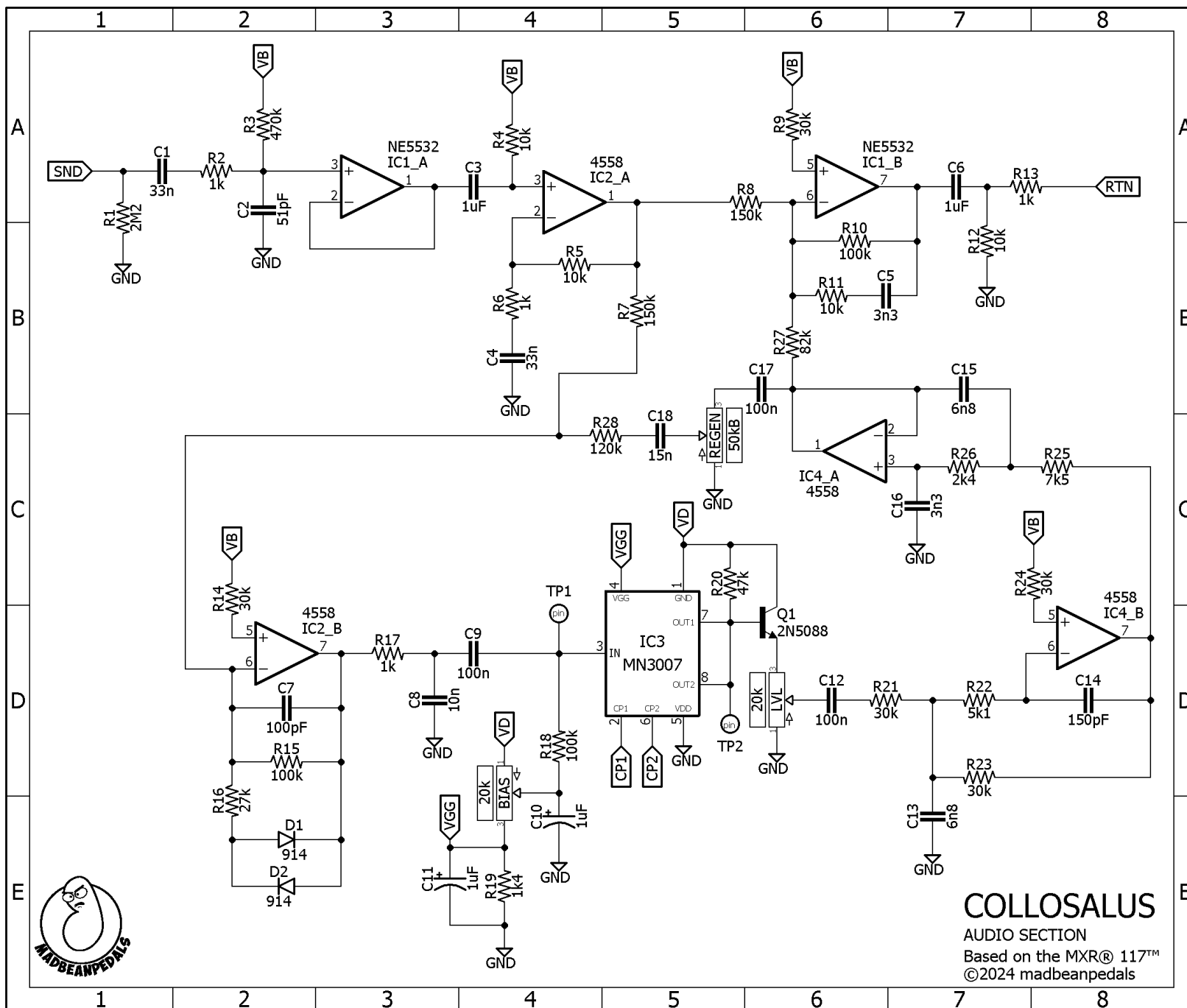

# Schematic

