

CURRENT LOVER

2015 ed. © madbearpedals

FX Type: Flanger

Based on the EHX® Electric Mistress™

3.35" W x 2.8" H

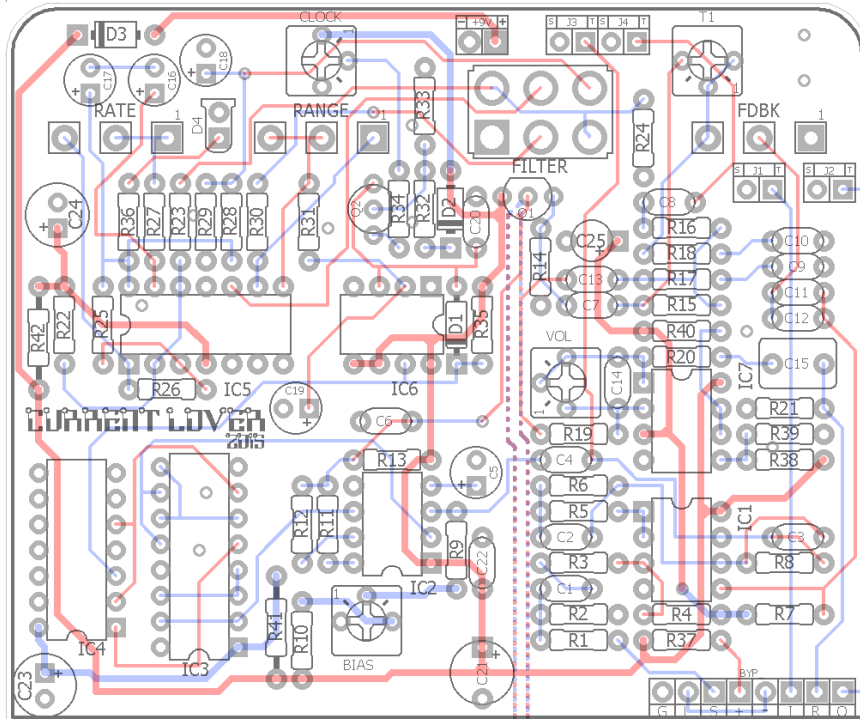
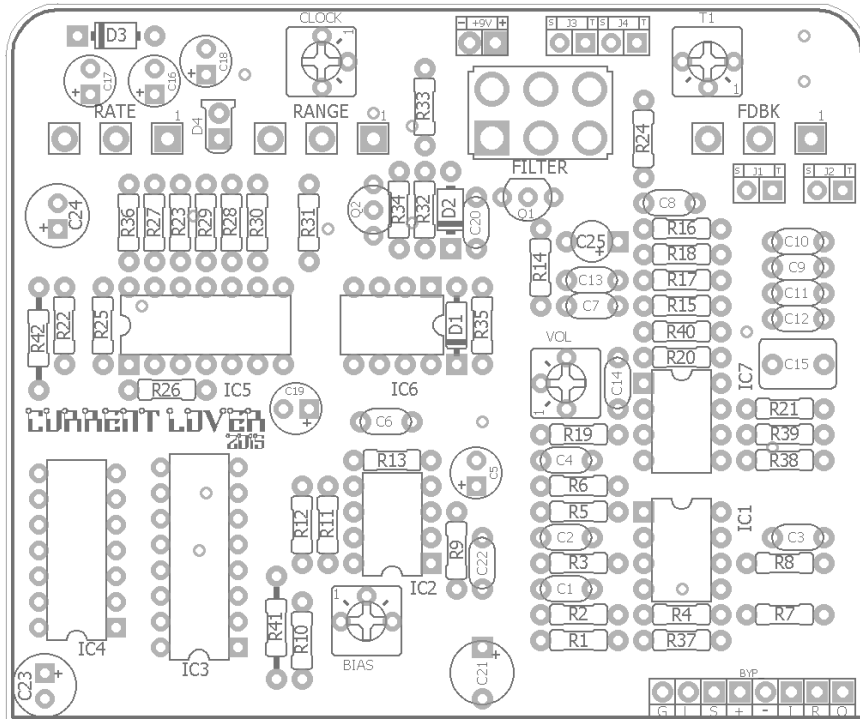

Terms of Use: You are free to use purchased **Current Lover** circuit boards for both DIY and small commercial operations. You may not offer **Current Lover** boards for resale or as part of a "kit" in a commercial fashion. Peer to peer re-sale is, of course, okay.

B.O.M.

Resistors		Resistors		Caps		Diodes	
R1	5k6	R26	30k	C1	39n	D1	1n914
R2	1M	R27	3k9	C2	47n	D2	1N4007
R3	5k6	R28	47k	C3	1n	D3	1N5817
R4	1M	R29	27k	C4	100n	D4	LED
R5	470R	R30	15k	C5	10uF	Transistors	
R6	4k7	R31	33k	C6	680pF	Q1	2N3904
R7	100k	R32	62k	C7	68n	Q2	2N5087
R8	5k6	R33	1M2	C8	220n	IC's	
R9	100k	R34	3k9	C9	47n	IC1	4558
R10	82k	R35	10k	C10	47n	IC2	MN3007
R11	4k7	R36	1k	C11	3n3	IC3	CD4049
R12	4k7	R37	4k7	C12	2n2	IC4	CD4013
R13	47k	R38	200k	C13	220n	IC5	LM324
R14	10k	R39	200k	C14	100pF	IC6	LM311
R15	8k2	R40	1k	C15	1uF	IC7	4558
R16	13k	R41	22R	C16	33uF	Switch	
R17	470R	R42	22R	C17	33uF	FILTER	DPDT
R18	470R			C18	1uF	Trimmers	
R19	10k			C19	1uF	CLOCK	10k
R20	470R			C20	22pF	T1	10k
R21	100k			C21	220uF	BIAS	100k
R22	39k			C22	100n	VOL	50k
R23	24k			C23	100uF	Pots	
R24	8k2			C24	100uF	RANGE	100kB
R25	10k			C25	10uF	RATE	1MC
						FDBK	10kB

Shopping List

Value	QTY	Type	Rating	Value	QTY	Type	Rating
22R	2	Carbon / Metal Film	1/4 or 1/2W	47n	3	Film	25v min.
470R	4	Carbon / Metal Film	1/4W	68n	1	Film	25v min.
1k	2	Carbon / Metal Film	1/4W	100n	2	Film	25v min.
3k9	2	Carbon / Metal Film	1/4W	220n	2	Film	25v min.
4k7	4	Carbon / Metal Film	1/4W	1uF	1	Film	25v min.
5k6	3	Carbon / Metal Film	1/4W	1uF	2	Electrolytic	25v min.
8k2	2	Carbon / Metal Film	1/4W	10uF	2	Electrolytic	25v min.
10k	4	Carbon / Metal Film	1/4W	33uF	2	Electrolytic	25v min.
13k	1	Carbon / Metal Film	1/4W	100uF	2	Electrolytic	25v min.
15k	1	Carbon / Metal Film	1/4W	220uF	1	Electrolytic	25v min.
24k	1	Carbon / Metal Film	1/4W	1n914	1		
27k	1	Carbon / Metal Film	1/4W	1N4007	1	or, 1N4001, 1N4004	
30k	1	Carbon / Metal Film	1/4W	1N5817	1		
33k	1	Carbon / Metal Film	1/4W	LED	1	your choice (LFO indicator)	
39k	1	Carbon / Metal Film	1/4W	2N3904	1		
47k	2	Carbon / Metal Film	1/4W	2N5087	1		
62k	1	Carbon / Metal Film	1/4W	4558	2		
82k	1	Carbon / Metal Film	1/4W	MN3007	1		
100k	3	Carbon / Metal Film	1/4W	CD4049	1		
200k	2	Carbon / Metal Film	1/4W	CD4013	1		
1M	2	Carbon / Metal Film	1/4W	LM324	1		
1M2	1	Carbon / Metal Film	1/4W	LM311	1		
22pF	1	Ceramic / Mica	25v min.	DPDT	1	On/On, Solder Lug or Pin	
100pF	1	Ceramic	25v min.	10k	2	Bourns 3362P	
680pF	1	Ceramic	25v min.	100k	1	Bourns 3362P	
1n	1	Film	25v min.	50k	1	Bourns 3362P	
2n2	1	Film	25v min.	100kB	1	PCB Right Angle	16mm
3n3	1	Film	25v min.	1MC	1	PCB Right Angle	16mm
39n	1	Film	25v min.	10kB	1	PCB Right Angle	16mm

Tip: You can use a single 5n6 cap for C11/C12 instead of the 2n2/3n3 in parallel.

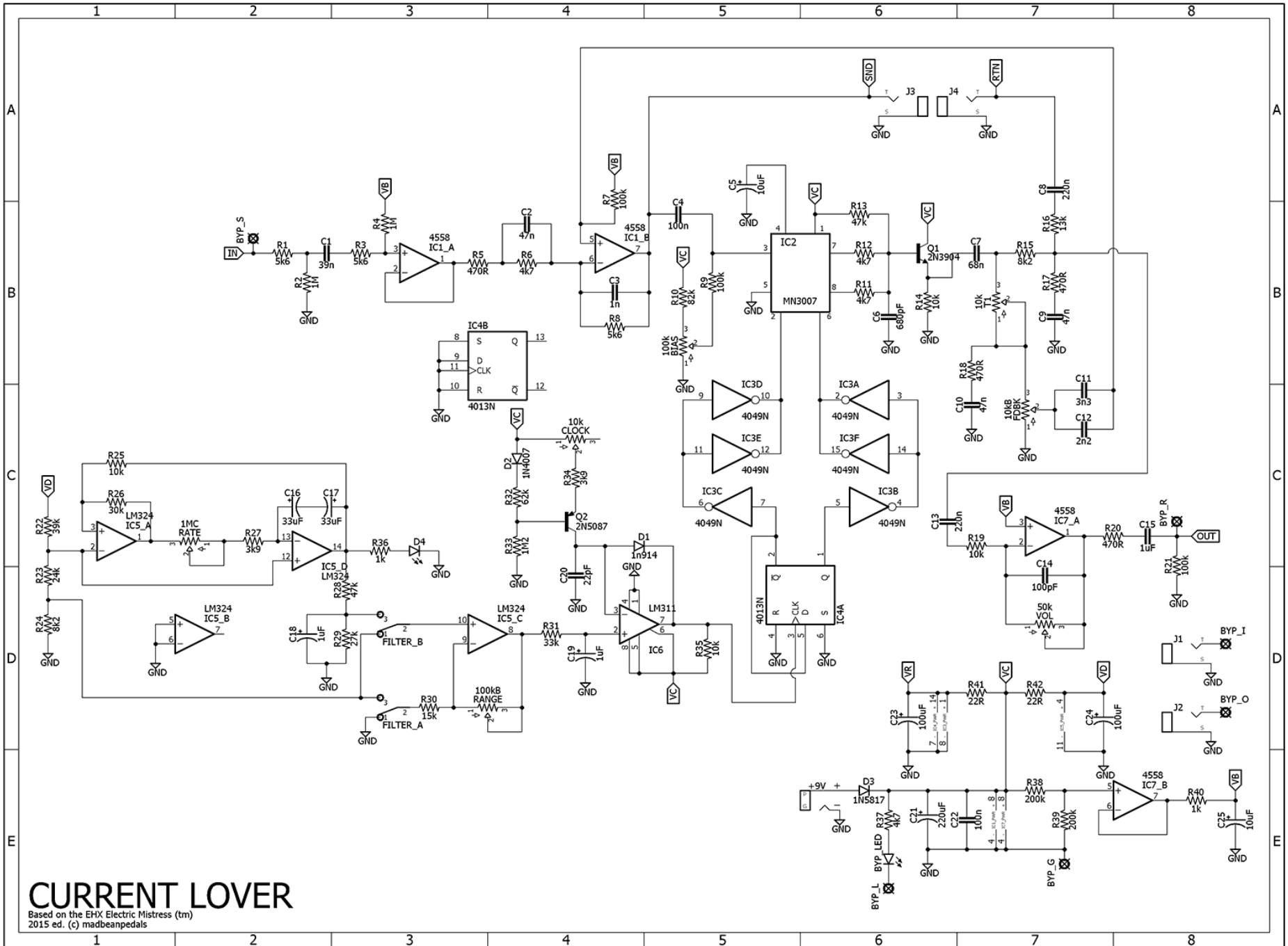

CURRENT LOVER

Based on the EHX Electric Mistress (tm)
2015 ed. (c) madbeanpedals

1590BB Drill Template

5.79" W x 6.82" H

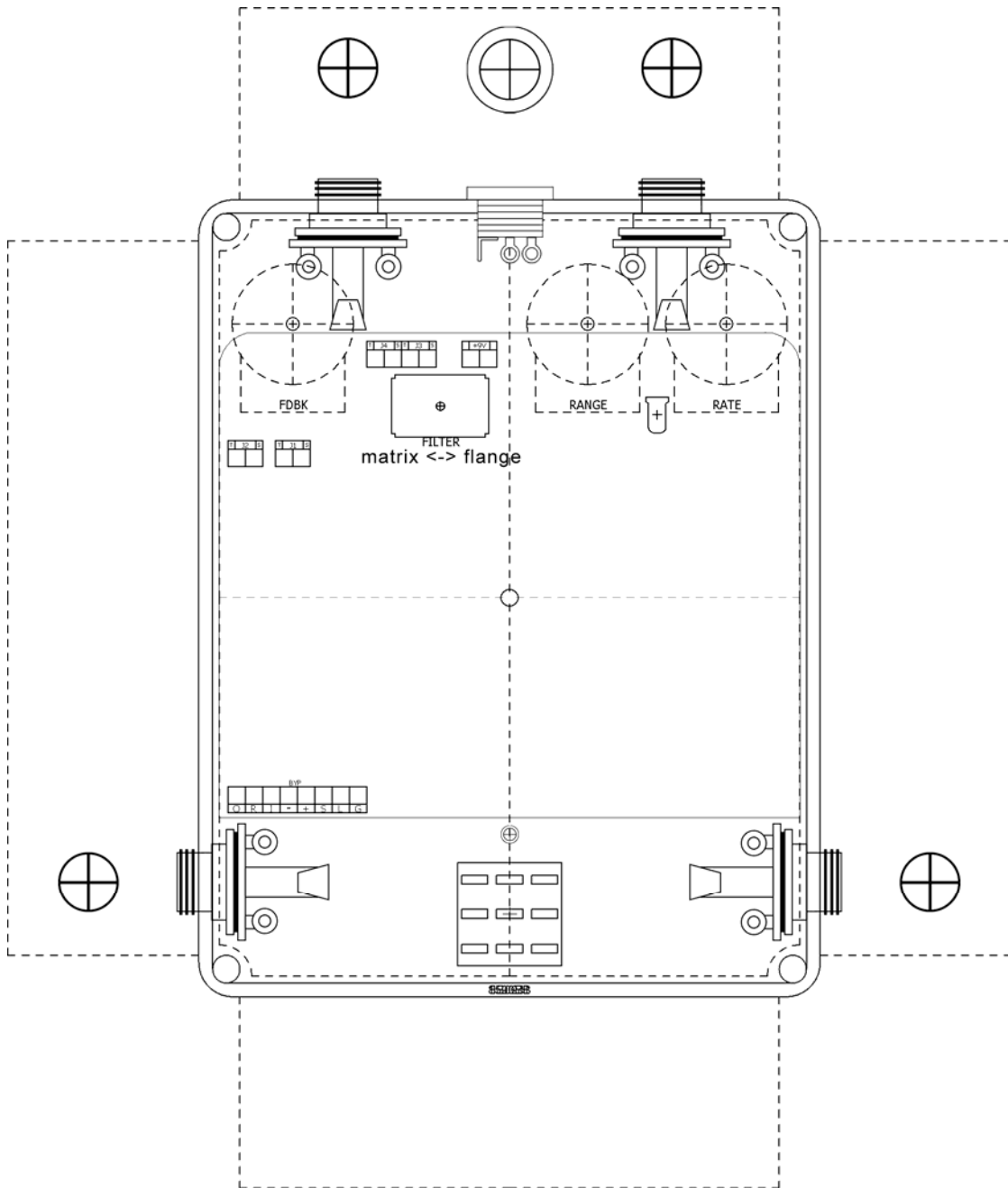

This template is for a 1590BB when using the optional Send/Return effects loop. The send/return jacks go up top and in/out jacks go on the bottom. If using this template, I highly recommend using either the Lumberg or plastic enclosed jacks for Input and Output on the bottom because they are not as wide as open-frame metal jacks.

Jacks:

<http://smallbear-electronics.mybigcommerce.com/lumberg-1-4-compact-shrouded-mono-jack/>

<http://smallbear-electronics.mybigcommerce.com/1-4-in-mono-enclosed-111/>

1590BB Drill Template

5.79" W x 6.82" H

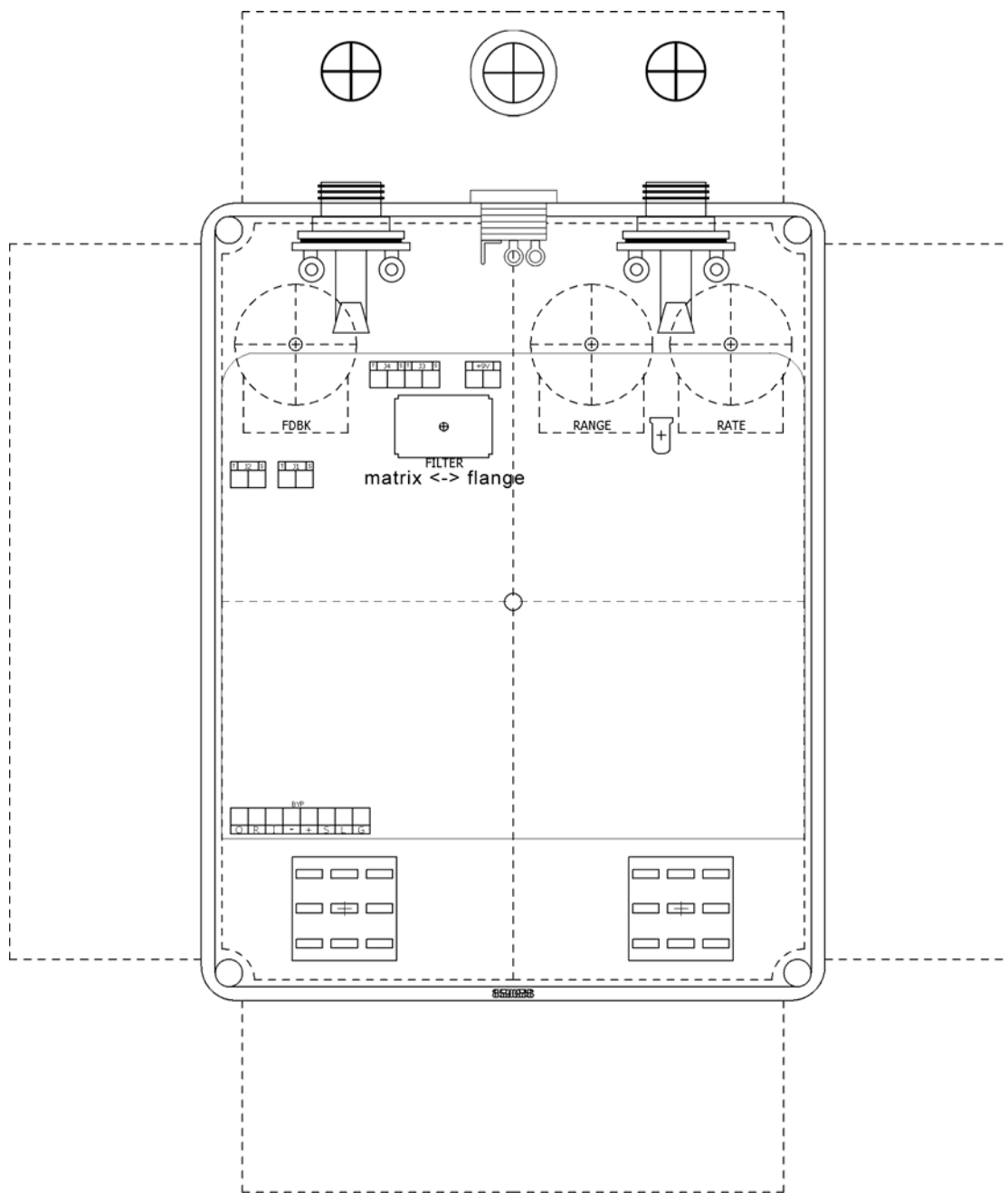

This is an alternate 1590BB template you can use if you omit the send/return jacks. Here the PCB is moved further away from the top edge to allow a little more clearance for the input/output jacks. Just for a bit of asymmetrical fun, you could use one of the two possible 3PDT locations I've shown. The indicator LED could be soldered directly to the PCB or placed somewhere else. Up to you!

125BB Drill Template

6.46" W x 7.49" H

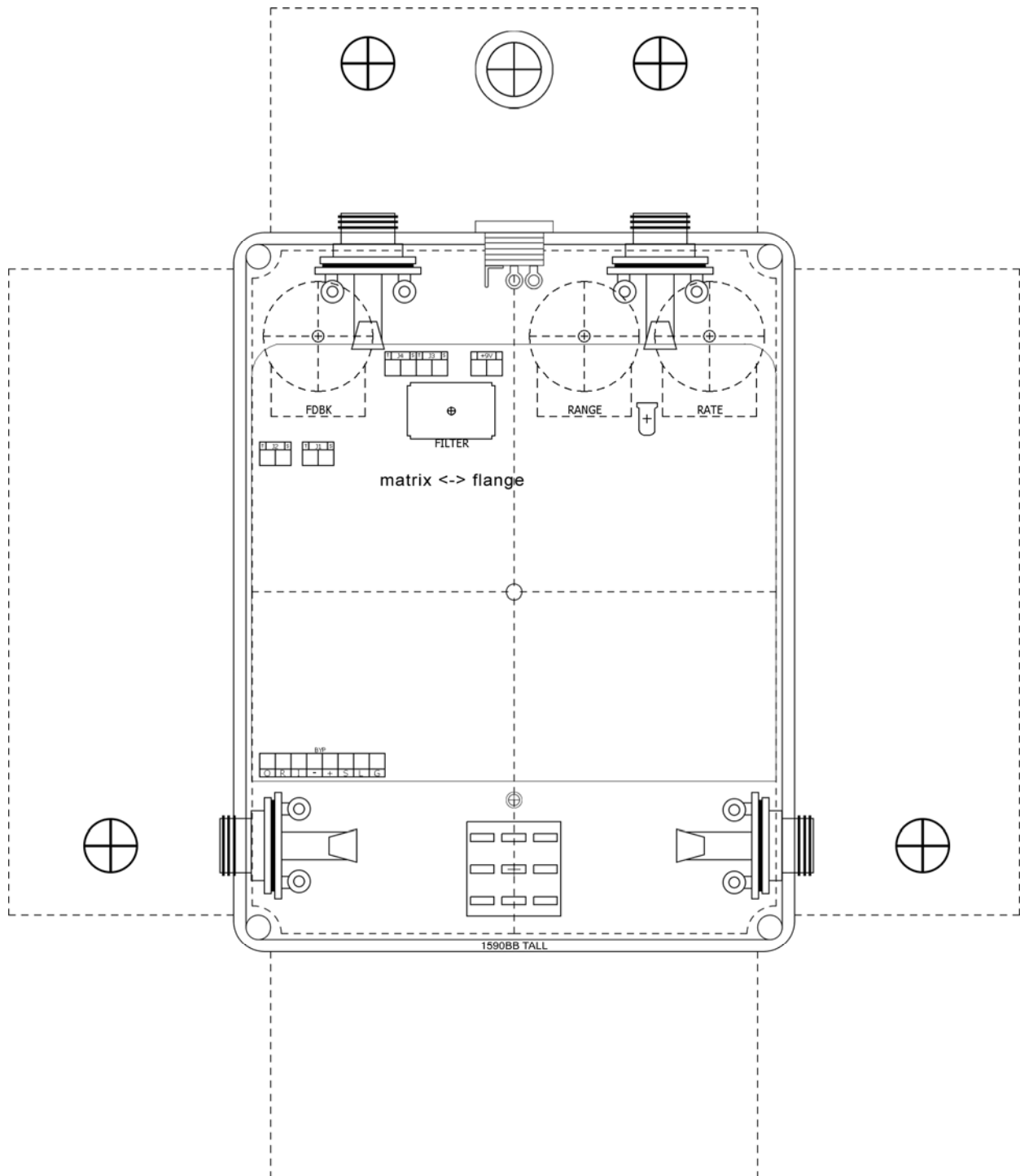

This template is for a 125BB and the one I would personally choose. It's the same footprint as the 1590BB, but the same height as the 125B. The extra room will make for easier jack clearance up top without compromising on enclosure size. I still recommend using the same jacks if you are doing the send/return option.

Jacks:

<http://smallbear-electronics.mybigcommerce.com/lumberg-1-4-compact-shrouded-mono-jack/>

<http://smallbear-electronics.mybigcommerce.com/1-4-in-mono-enclosed-111/>

Wiring Guide 1

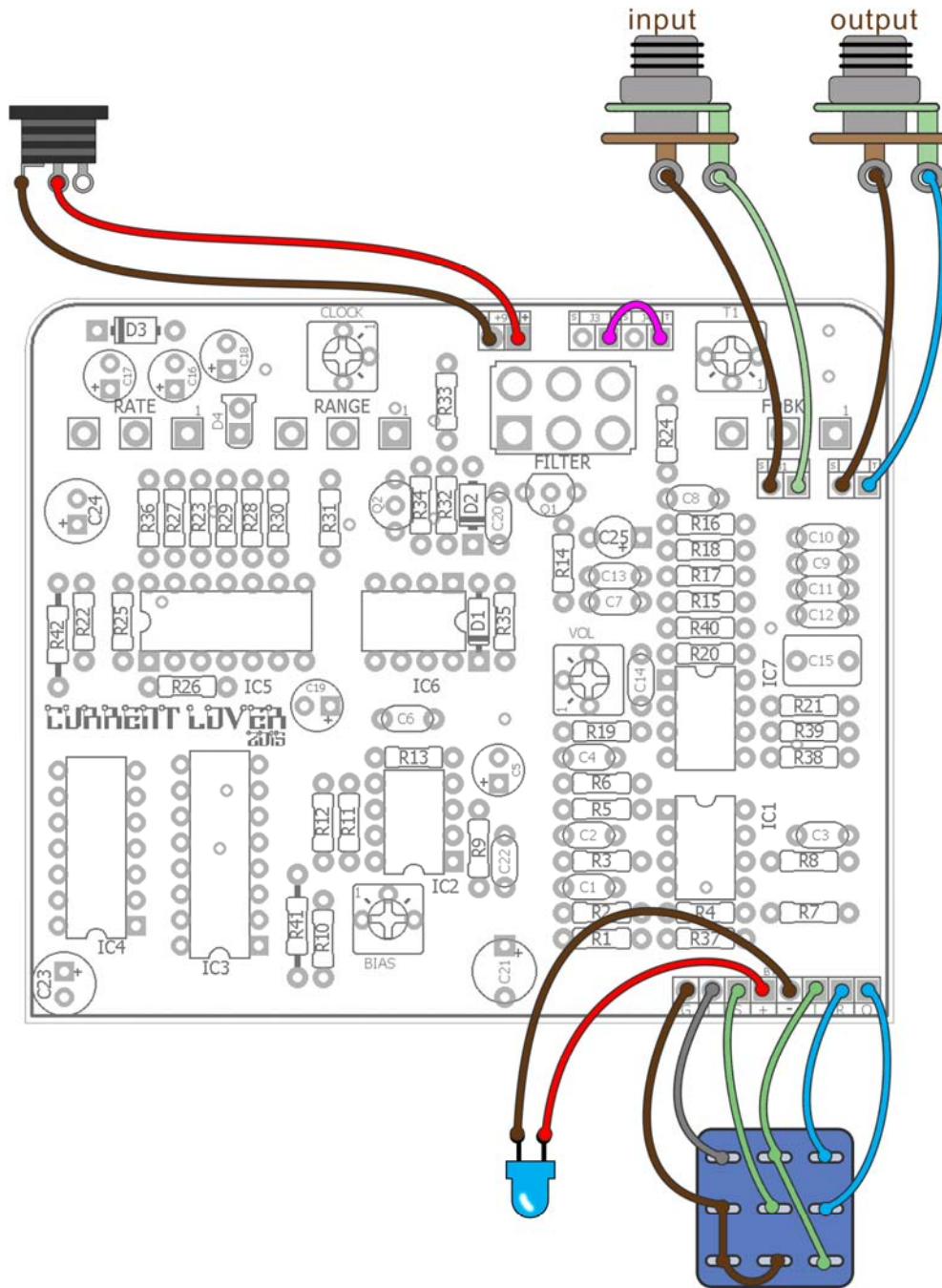

Use this guide when not opting for the send/return jacks. Note that you need to jumper the tips of J3/J4 together (pink wire up top).

Wiring Guide 2

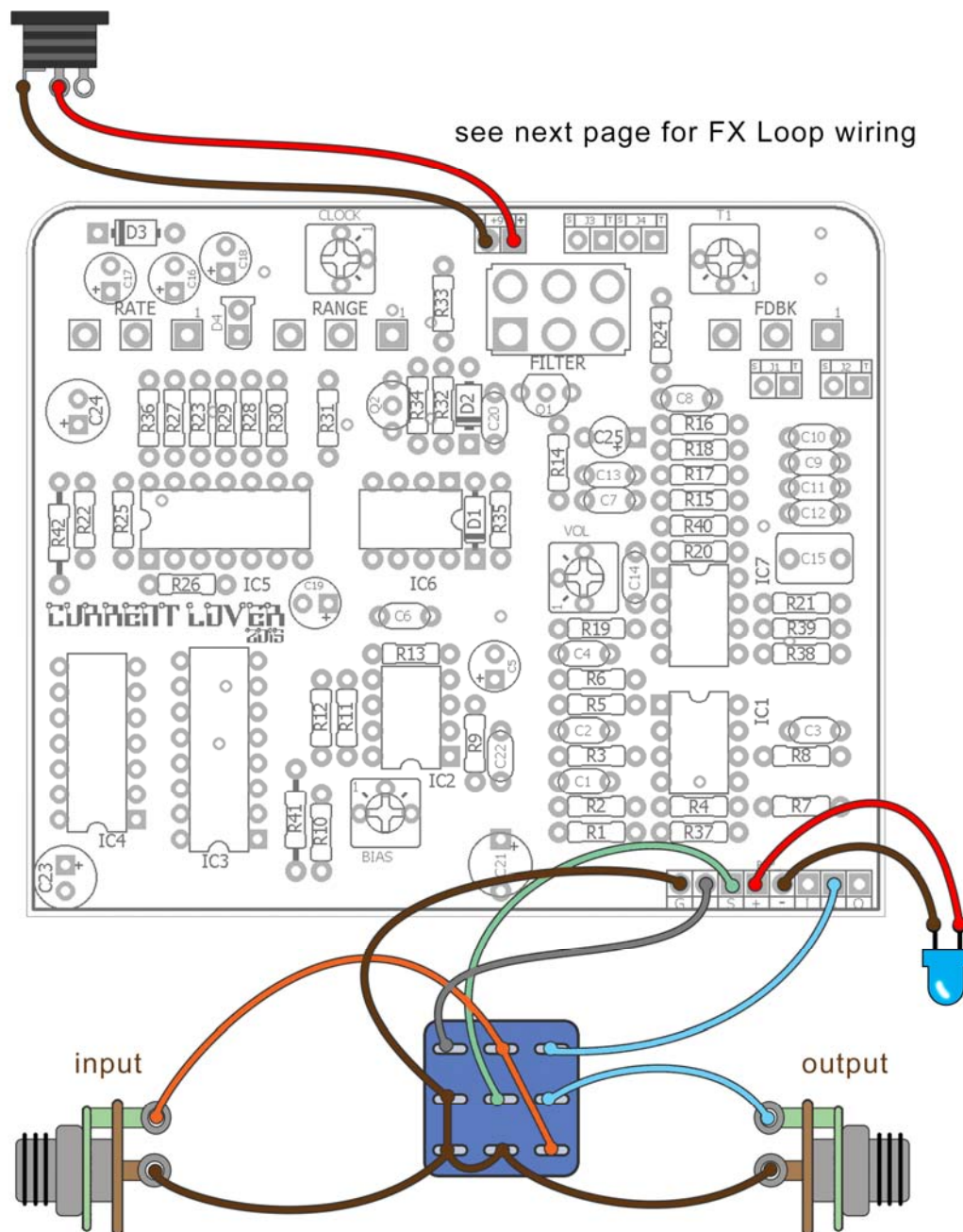

Use this guide when wiring the Current Lover with the optional FX Loop (send/return jacks). Here it is better to skip the J1/J2 connections on the PCB and just wire the input and output jacks directly to the switch. No reason to have extra long wires running across the PCB! See the next page for wiring the loop.

FX Loop Wiring

There are two ways you could wire the FX Loop. You could just use normal mono jacks and wire J3 and J4 as you would any other mono jack. However, this means you would have to use an extra patch cord to connect the two ends of the signal together when not using an insert. Not very elegant. Instead, let's use a different kind of jack which will stay connected to one another when we are not using an insert.

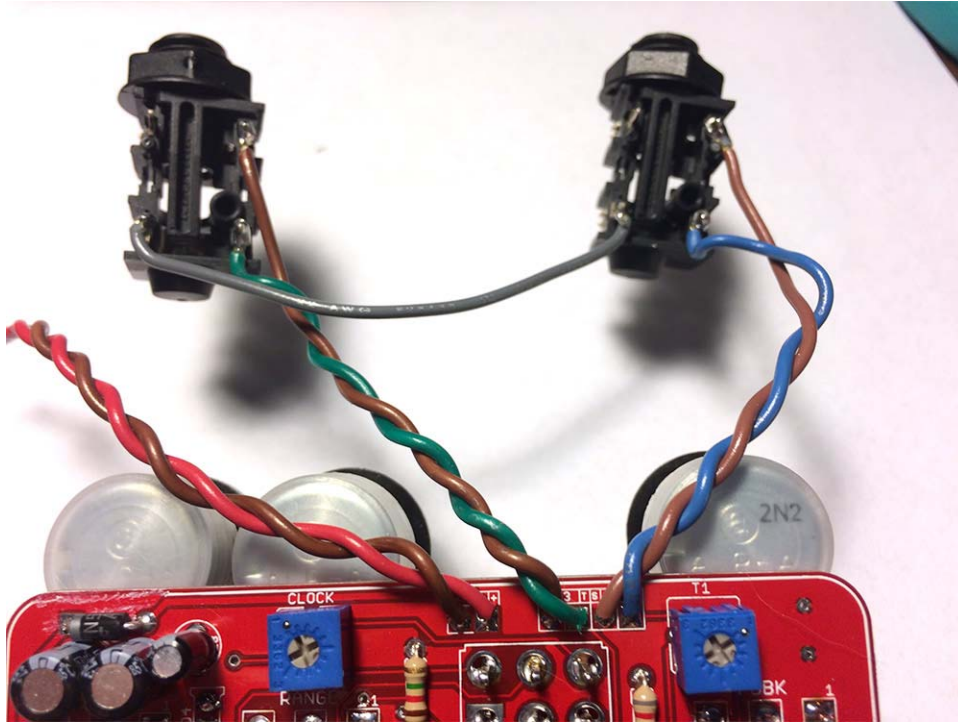

Here I have used “switched” jacks for the send and return. The switched jack allows you to connect the tips of two jacks together when there is nothing plugged into them, and then have that connection broken when a plug is inserted in to either or both jack. In the pic above, the green wire goes to the tip of the send jack, the blue to the tip of the return jack and the two brown wires are both ground. The grey wire connects the green and blue wires together. This allows normal operation when there is nothing plugged into the effect loop.



Here is a close-up of the send jack. When the plug is inserted, the connection between the grey wire and the tip is broken, allowing you to send the signal to another effect, and the return that effected signal to the return jack. The area in the red circle shows the broken connection.

You should be able to use any mono switched jack for this. The jacks in the pics are from Mouser:
<http://www.mouser.com/Search/ProductDetail.aspx?R=NRJ4HFvirtualkey56810000virtualkey550-10284>

Smallbear also has switched mono jacks:
<http://smallbear-electronics.mybigcommerce.com/1-4-enclosed-nmj4hcd2/>

You could also use these tiny 1/8" jacks, although you would need to make two 1/8" to 1/4" conversion cables:
<http://smallbear-electronics.mybigcommerce.com/1-8-mono-pc-mount/>

Voltages

IC1 4558		IC2 MN3007		IC3 CD4049		IC4 CD4013	
1	4.59	1	9.13	1	9	1	4.53
2	4.59	2	~4.45	2	4.5	2	4.53
3	4.18	3	~4.85	3	4.5	3	varies
4	0	4	41mV	4	4.5	4	0
5	4.51	5	0	5	4.53	5	4.5
6	4.55	6	~4.45	6	4.5	6	0
7	4.53	7	~4.2	7	4.5	7	0
8	9.13	8	~4.2	8	0	8	0
				9	4.5	9	0
				10	4.5	10	0
				11	4.5	11	0
				12	4.5	12	9
				13	ignore	13	0
				14	4.5	14	9
				15	4.5		
				16	ignore		

IC5 LM324		IC6 LM311		IC7 4558	
1	varies	1	0	1	4.55
2	~4.2	2	varies	2	4.55
3	varies	3	varies	3	4.55
4	9	4	0	4	0
5	0	5	9.14	5	4.51
6	0	6	9.14	6	4.55
7	7.8	7	varies	7	4.55
8	varies	8	9.14	8	9.14
9	varies				
10	varies				
11	0				
12	~4.2				
13	~4.2				
14	varies				

Supply: One Spot measuring 9.4vDC

Many pins will vary in voltage in this circuit. When comparing voltages make sure you are getting 9v and 0v where indicated. Some voltages may “wobble” a bit which is indicated by the “~”. This might have been due to my use of 1/4W resistors rather than 1/2W in my build. This does not seem to be critical to the function of the effect, however.

The Current Lover should also run on 12vDC. It may work at 15v (maximum allowable by the MN3007) but this might require some clock/bias tweaking. YMMV.

New for the 2015 Edition

Layout – All new layout fitted for the 1590BB or 125BB. This layout provides better separation between audio/power and LFO sections than the previous version. The use of a larger enclosure will make it easier to use the optional effects loop, if desired.

Circuit – This project no longer offers the option of using the MN3207; only the MN3007. This change was made to try and reduce the difficulty of the build *and* in providing tech support. The Clock trimmer is now 10k instead of 100k, which will make calibration easier. The volume control from the previous version is now a trimmer and the output section was changed from a transistor to op-amp style gain stage.

What Is It?

The **Current Lover** is an adaptation of the Electro-Harmonix Electric Mistress™ flanger for 9v operation. It offers very warm and rich flanging while maintaining low noise operation and flexibility in its controls. Additions to the vintage Mistress design are included. These are a buffered clock signal to the BBD, an FX loop for through-zero flanging and an output gain stage to match or exceed the bypass volume.

Much of the development of the **Current Lover** was based on the work by presented by Thomeeque on DIYstompboxes and therefore much gratitude is owed to him for making it available. Thank you! While there is no single sided artwork available for the **Current Lover**, if you wish to etch your own Electric Mistress board, please check out his threads on DIYSB.

Controls

Rate – Controls the speed of the LFO which drives the flanger effect.

Range – Controls the overall depth of the flanging effect.

Fdbk – This is the amount delay line signal sent back to the input of the BBD. Higher levels of feedback increase the complexity of the flanged signal and can yield some intense, airplane flanging.

Filter - This DPDT switch disconnects the LFO for a mild to moderate ring-modulator effect. This effect can be influenced with the **Range** and **Feedback** controls.

Trimmers

Vol – This is the output volume of the added gain stage at the end of the effect.

T1 – Sets a limit on the maximum amount of Feedback possible.

Clock – Sets the correct voltage to run the oscillator through the clocks which drive the BBD delay lines.

Bias – Sets the correct voltage bias to the input of the BBD.

Notes

Be wary of purchasing MN3007 chips online. There are some oversea sellers on eBay offering fake or counterfeit chips. It is best to purchase the MN3007 or MN3207 from a reliable source like Smallbear, or other DIY'ers, if possible.

The Current Lover has an optional effect loop. This loop is in parallel with the delay line and allows you to insert another effect to create new/unusual/weird sounds. For instance, you could try putting another flanger in the effects loop to approximate through-zero flanging. Or, perhaps another modulation effect like a phaser. It's up to you. Or, you can exclude the loop altogether if you don't want to mess with it. Details are provided in this document on how to build the Current Lover with and without the effect loop. As with any effect loop, not everything you try is a guaranteed success. It will take experimentation to figure out what works.

When this project was originally developed in 2011, I did not have any humbucker-equipped guitars. Now that I do I did notice that the Current Lover is not as forgiving with high output pups. Some distortion may occur...not unpleasant, but if you primarily use high output pickups and are a stickler for cleanliness you may want to tweak the circuit a bit. My suggestion is to increase the in-line resistance at the input of the effect if this occurs. Socket R1 and try higher values; 47k – 100k is suggested.

C11 and C12 form to caps in parallel to approximate the 5n6 in the stock unit. Honestly, I don't know why I left this in there for the update. If you have a 5n6 cap, just use that in either the C11 or C12 position instead of a 3n3 and 2n2 resp.

Calibrating

The Current Lover must be correctly calibrated to function properly. This is done with the Clock and Bias trimmers. These work independently from one another but require some re-adjustments as you work through calibration. The Clock trimmer is very sensitive to fine adjustment so be prepared to spend a few minutes getting the right setting.

Before powering up the board and connecting your guitar and amp, set the **Clock** and **Bias** trimmers to their middle position. Set the **T1** trimmer and **Rate** pot fully counter-clockwise. Finally, set the **Range**, **Volume** and **Feedback** pots to approximately their middle positions and the **Filter** switch to the right position. Now connect the board between your guitar and amp and power it up. You should get signal through the effect, although you may not hear any flanging yet. If you do not have any signal, double check your connections and ensure that there are no bugs in your build.

First adjust the **Bias** trimpot until you get some flanging. You don't have to be precise, just get the BBD working. Next adjust the **Clock** trimpot to the point where you achieve a wide sweep with minimum noise. If the flange starts to whine or "chirp" at the extremes of its sweep you will need to do a little more adjustment. Go back and tweak the **Bias** trimpot further clockwise until you get smooth up and down flange without distortion. Set the Feedback control fully clockwise and gently adjust **T1** clockwise until you get the maximum feedback desired (**T1** acts as a limit to the maximum allowed feedback). Continue making minor adjustments to the trimmers while testing the limits of the Rate, Range and Feedback controls. Describing this process makes it seem more complicated than it actually is: your ear will be the guide in achieving the best sound across the widest range of control settings.

The most important thing to balance here is the Clock trimmer. You need to make sure you get no "chirping" at the extremes of flanging when you set the Range, Fdbk and Rate pots fully up. Like I said before...very minute adjustments to the Clock trimmer make a big difference. Most of the adjustment will occur in the first ¼ turn of the trimmer.

