

VFE PALE HORSE™

FX TYPE: Overdrive

Images © VFE

Project Doc © madbeanpedals

7.31.17 update – see pg.2

2.17" x 2.025" H

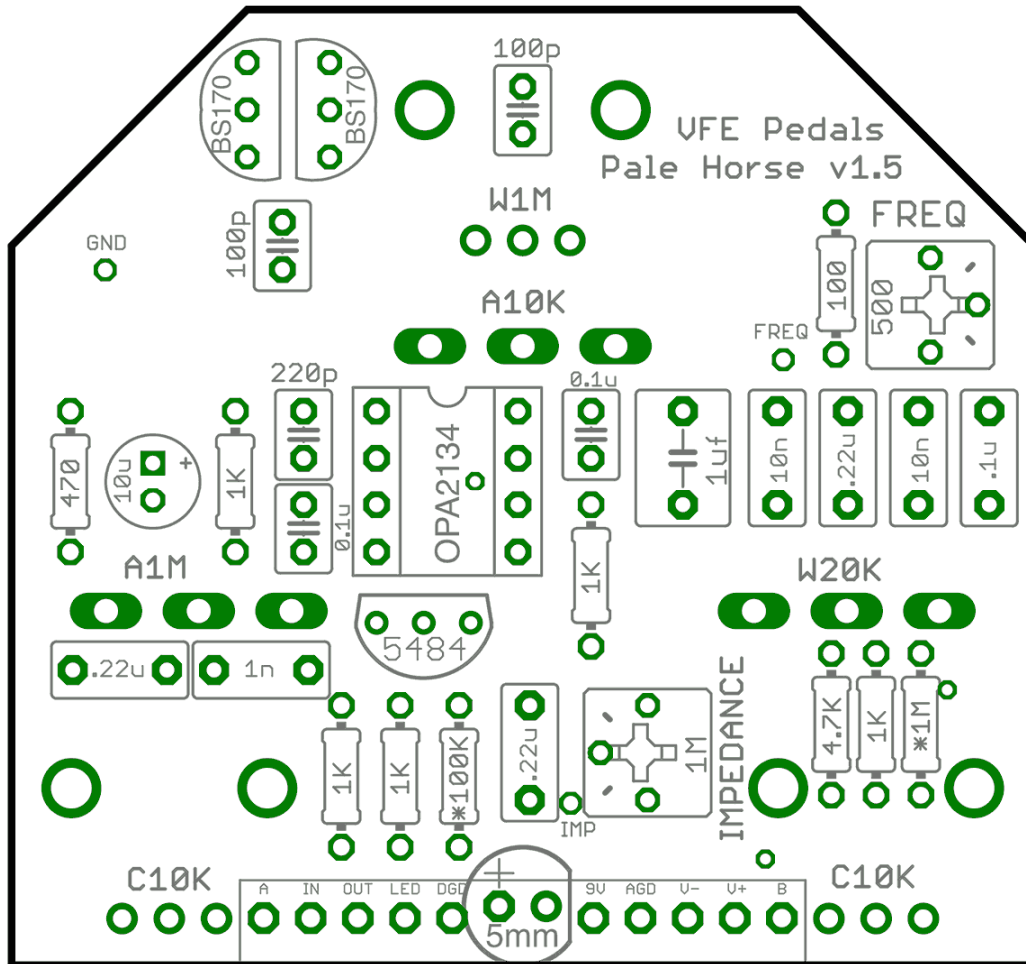

Axial parts

- 1 x 100
- 1 x 470
- 5 x 1K
- 1 x 4.7K
- 1 x 100K
- 1 x 1M

2.5mm caps

- 2 x 100p
- 1 x 220p
- 2 x 0.1u

5mm caps

- 1 x .1u
- 1 x 1n
- 2 x 10n
- (polypropylene)
- 3 x .22u
- 1 x 1u

Other

- 1 x OPA2134
- 1 x 500 trim
- 1 x 1M trim
- 1 x 2N5484
- (or J113)
- 2 x BS170
- 1 x 10u bipolar

Note: 10kA level pot on the PCB is actually 50kA.

REMINDER: PETER RUTTER / VFE DOES NOT PROVIDE SUPPORT FOR THESE PROJECTS. PLEASE DO NOT CONTACT HIM FOR QUESTIONS OR TECHNICAL SUPPORT. VISIT THE VFE SECTION OF THE MADBEANPEDALS FORUM FOR QUESTIONS AND ANSWERS!

Terms of Use: These projects are intended for DIY use only and may not be used in any commercial Endeavour including the sale of completed pedals or "kits". The PCBs are the actual boards used to build the recently discontinued line of VFE pedals and have been generously provided to the DIY community by VFE for the purpose of DIY only.

Shopping List

Value	QTY	Type	Rating	Notes
100R	1	Metal / Carbon Film	1/4W	
470R	1	Metal / Carbon Film	1/4W	
1k	5	Metal / Carbon Film	1/4W	
4k7	1	Metal / Carbon Film	1/4W	
100k	1	Metal / Carbon Film	1/4W	
1M	1	Metal / Carbon Film	1/4W	
100pF	2	MLCC / Ceramic	25v min	2.54mm spacing
220pF	1	MLCC / Ceramic	25v min	2.54mm spacing
1n	1	Film	25v min	
10n	2	Film / Polypropylene	25v min	
100n	2	MLCC / Ceramic	25v min	2.54mm spacing
100n	1	Film	25v min	
220n	3	Film	25v min	
1uF	1	Film	25v min	
10uF BP	1	Bi-Polar	25v min	
2n5484	1	or, J113		
BS170	2			
OPA2134a	1			
500R	1	Bourns 3362p		
1M	1	Bourns 3362p		
20kW	1	PC Mount Right Angle	16mm	
50kA	1	PC Mount Right Angle	16mm	
10kC	2	PC Mount Right Angle, Plastic Shaft	9mm	
1MD	1	PC Mount Right Angle	16mm	Included w/PCB
W1M [C]	1	PC Mount Right Angle, Plastic Shaft	9mm	

This list is for the audio board only. See the appropriate Switching Board doc for the parts needed for the switching system.

2.54mm MLCC

100pF: <http://www.mouser.com/ProductDetail/KEMET/C320C101J5G5TA/?qs=sGAEpiMZZMt3KoXD5rJ2N54QGdmfVhtg63%252bt7NgZMo0%3d>

220pF: <http://www.mouser.com/ProductDetail/KEMET/C320C221J2G5TA/?qs=sGAEpiMZZMt3KoXD5rJ2N%252bwgB11a522xefKl%252bxFregl%3d>

100n: <http://www.mouser.com/Search/ProductDetail.aspx?R=C320C104K5R5TAVirtualkey6460000Virtualkey80-C320C104K5R>

You can also just use regular 5mm spaced ceramics or MLCC if you bend the leads inward a bit so don't feel like you have to order the Mouser parts.

2n5484: <http://smallbear-electronics.mybigcommerce.com/transistor-fet-2n5484/>

Note: You must use the 2n5484 or J113 for proper operation!

10n Polypropylene: If you have these great (I don't) but if not just use your regular film caps.

10uF BP: <http://www.mouser.com/Search/ProductDetail.aspx?R=ECE-A1EN100UVirtualkey66720000Virtualkey667-ECE-A1EN100U>

Smallbear does have 10uF BP, however they are a bit too large and 5.08mm spaced. I used two 4u7BP in parallel on my build.

OPA2134: <http://www.mouser.com/Search/ProductDetail.aspx?R=OPA2134PAVirtualkey5950000Virtualkey595-OPA2134PA>

Bourns 500R: <http://www.mouser.com/ProductDetail/Bourns/3362P-1-501LF/?qs=sGAEpiMZZMvygUB3GLcD7iDNIz%2fNDKompMEyhqEJhVo%3d>

Bourns 1M: <http://www.mouser.com/ProductDetail/Bourns/3362P-1-105LF/?qs=sGAEpiMZZMvygUB3GLcD7kddhVJPYv2kST8Lo8GI%252b%2f8%3d>

20kW / 50kA pots: <http://smallbear-electronics.mybigcommerce.com/alpha-single-gang-16mm-right-angle-pc-mount/>

10kC pots: <http://www.taydaelectronics.com/potentiometer-variable-resistors/rotary-potentiometer/anti-log-reverse/10k-ohm-anti-log-taper-potentiometer-round-knurled-plastic-shaft-pcb-9mm.html>

10kC is harder to come by in the 9mm variety (only available at Tayda AFAIK) – you can use 10kA as a sub.

The **IMD** pot (DRIVE) is a IMA but with 10% tolerance instead of 20%. The **W1M [C]** (COMP) is a IM pot with a W taper and center detent.

July 31st update: All the W1M [C] taper pots are gone and will no longer be included with this project. Use a regular 1MB pot in its place. The W1M [C] pot has a center detent which the 1MB pot does not. Both pots will cover the same tones although the 1MB pot may find similar settings in slightly different positions than the W1M [C]. The 1MD is still included with the PCBs.

1MB pot: <http://smallbear-electronics.mybigcommerce.com/alpha-single-gang-9mm-right-angle-pc-mount-w-knurled-plastic-shaft/>

Overview

You might be tempted to call the Pale Horse YATS, but if you take a closer look you'll see there is a lot more going on. A split-rail supply, tone shifting, impedance and clipping options plus a clever trick (a JFET as a constant current source on the output of the gain stage to increase headroom and dynamics) make for a unique and wide-ranging overdrive that can cover a lot of bases!

Controls

Descriptions from the VFE website: <http://vfepedals.com/pale-horse.html>

STONE: Active boost/cut of frequencies above the threshold set by the internal FREQ trimpot. Stock setting @ 3.2kHz.

FREQ: Internal trimpot to make the tone control a treble boost/cut, or higher up like a presence boost/cut (stock setting here is about 1/4 up).

DRIVE: Sets the gain in the drive section. From clean boost to a cascading layers of high gain saturation, there's more than enough range in this control to satisfy any of your tonal needs.

LEVEL: Sets the output level of the Pale Horse...and it can get LOUD!

IMPEDANCE: Sets the input impedance via an internal trimpot. Lower input impedances respond more dynamically to your guitar's volume knob, and higher impedances will add sparkle to the top end.

COMP: Uses Variable HCC technology to transition between a sweet, asymmetrical drive tone (counterclockwise) to a dynamic mosfet drive (clockwise). In between, there are many shades of compression and tone, with the 12:00 center-detent position locking in the clean boost mode.

HIGH: This post-gain treble cut lets you smooth out the character of your tone, or crank it up to add some gritty, bright top end.

LOW: The pre-gain bass cut lets you tighten up the bottom end to add punch, or turn it up for a thicker, full-range drive. Makes the Pale Horse a bass-friendly overdrive!

Variable HCC circuitry allows you to fine tune the harmonics, compression, and clipping character of your tone.

Notes

There are two components on the PCB labeled with "*" on them which indicate optional mods. These resistors can be socketed.

- The *100k allows you to change the lowest input impedance value of the OPA2134 when the IMPEDANCE trimmer is turned all the way down. You can other values here for experimentation. I found 100k to be a good overall value so you can just use that if you do not want to socket it.
- The *1M option seems to be included to set a high impedance input on the tone section and/or roll off some subs but I found this to not be needed on my build. YVMV.

The Pale Horse uses a split-rail supply. Make sure you follow the instructions in the Switching Board documentation to build it to this spec.

Remember – the Level pot should be 50kA, not the 10kA labeled on the PCB.



Pale Horse
<http://www.vfepedals.com/>

