

# TRACTOR BEAM™

FX TYPE: Phaser

Images © VFE and MBP

Project Doc © madbeanpedals

2.17" W x 2.02" H

Note: This project is built on the "Enterprise" PCB. It's the same circuit as the Tractor Beam with a few value modifications.

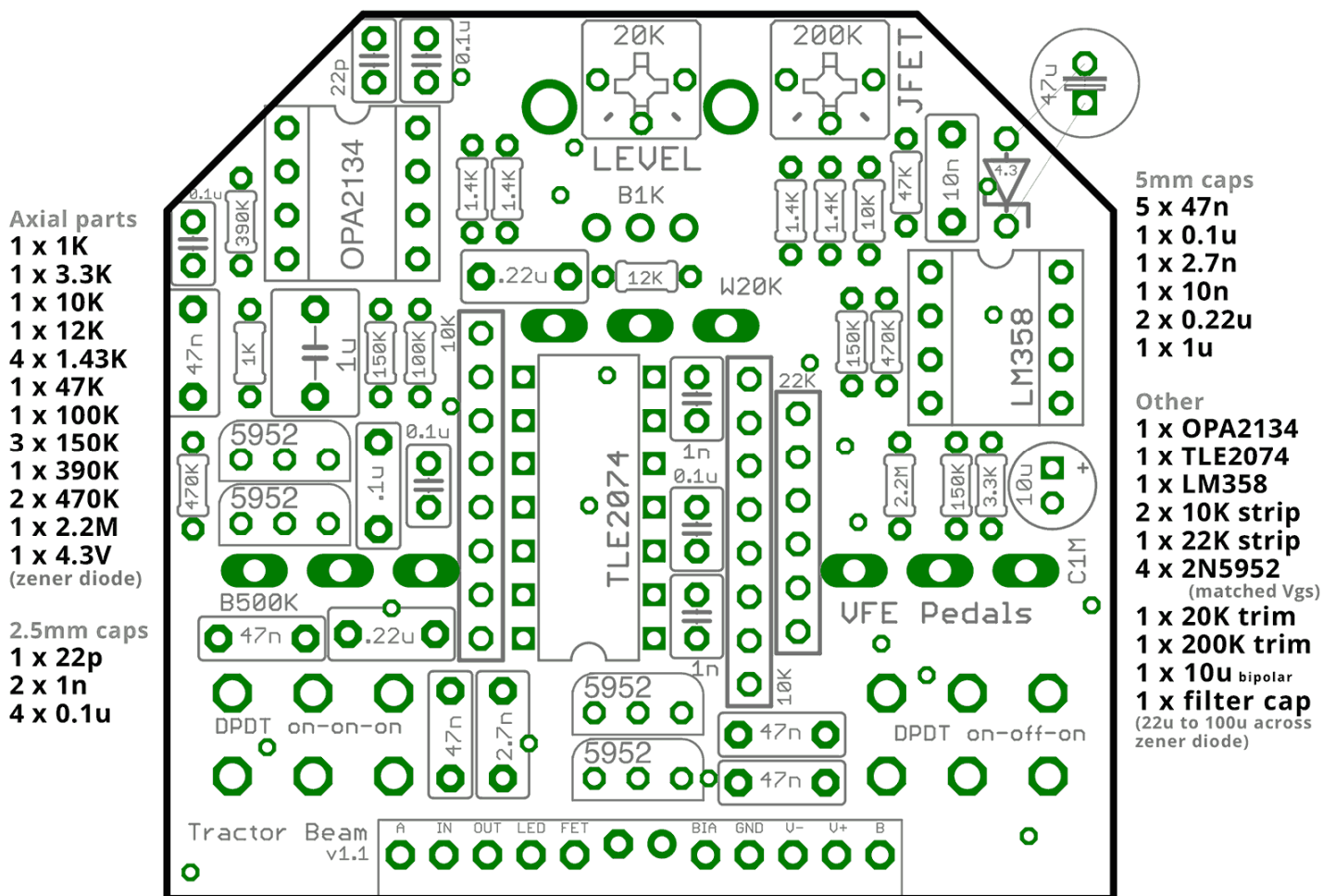

Note: Use the values listed on the image above – not the values indicated on the silk-screen of the PCB. Some values changed over time in the VFE product cycles.

**REMINDER: PETER RUTTER / VFE DOES NOT PROVIDE SUPPORT FOR THESE PROJECTS. PLEASE DO NOT CONTACT HIM FOR QUESTIONS OR TECHNICAL SUPPORT. VISIT THE VFE SECTION OF THE MADBEANPEDALS FORUM FOR QUESTIONS AND ANSWERS!**

**Terms of Use:** These projects are intended for DIY use only and may not be used in any commercial Endeavour including the sale of completed pedals or "kits". The PCBs are the actual boards used to build the recently discontinued line of VFE pedals and have been generously provided to the DIY community by VFE for the purpose of DIY only.

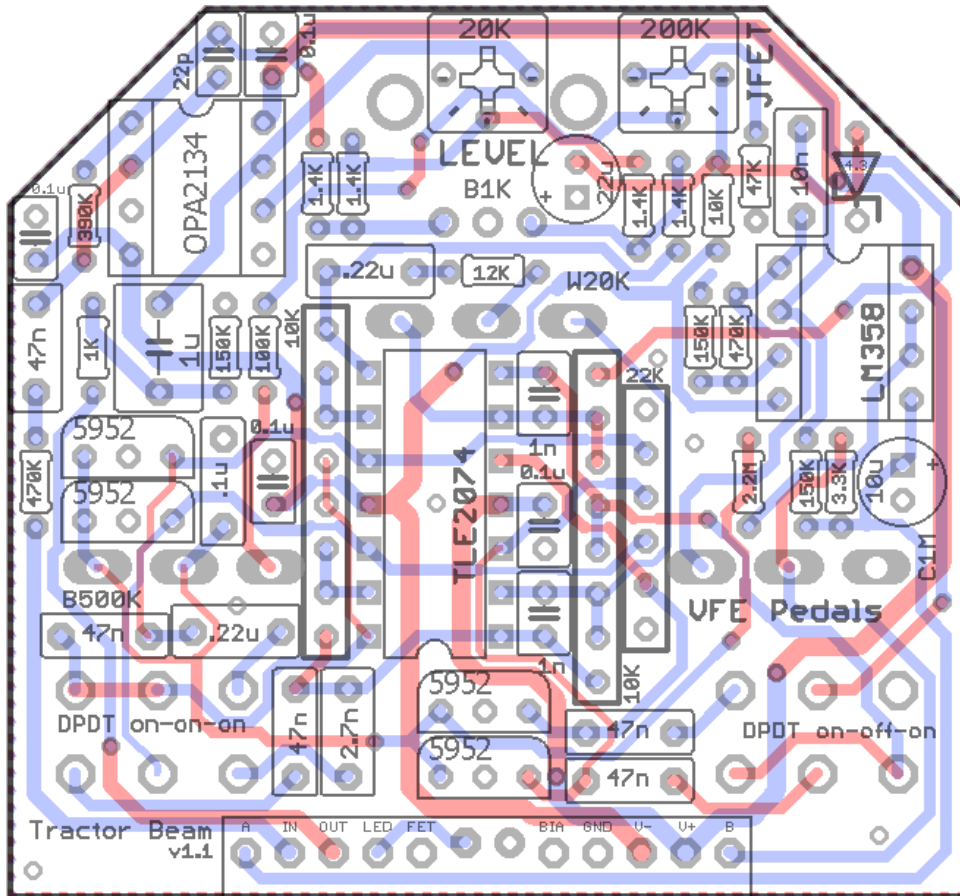

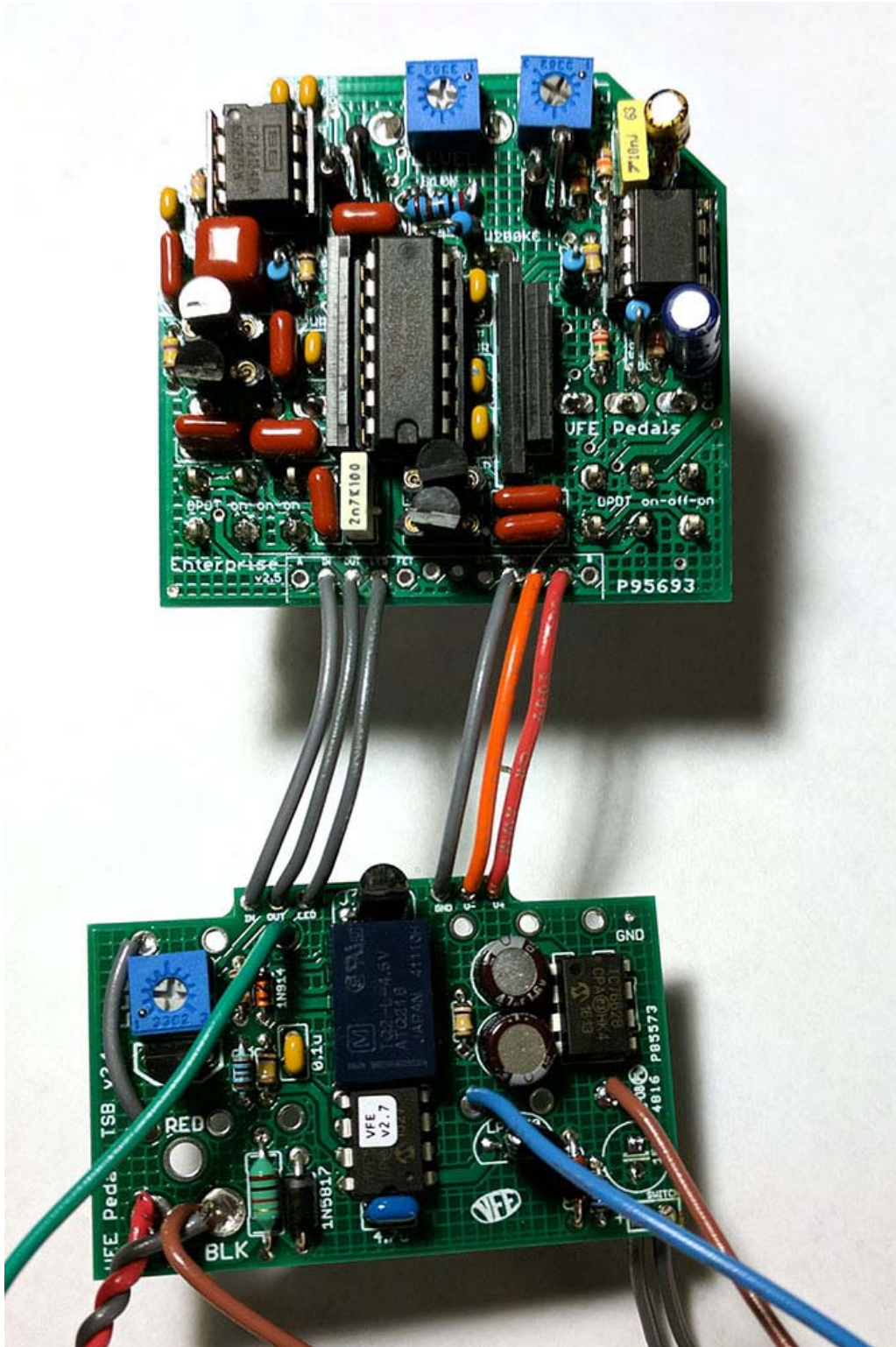

Shopping List				
Value	QTY	Type	Rating	Spacing
1k	1	Metal / Carbon Film	1/8W	
1k43	4	Metal / Carbon Film	1/8W	
3k3	1	Metal / Carbon Film	1/8W	
10k	1	Metal / Carbon Film	1/8W	
12k	1	Metal / Carbon Film	1/8W	
47k	1	Metal / Carbon Film	1/8W	
100k	1	Metal / Carbon Film	1/8W	
150k	3	Metal / Carbon Film	1/8W	
390k	1	Metal / Carbon Film	1/8W	
470k	2	Metal / Carbon Film	1/8W	
2M2	1	Metal / Carbon Film	1/8W	
10k	2	Resistor Array		
22k	1	Resistor Array		
22pF	1	MLCC	25v min	2.5mm
1n	2	MLCC	25v min	2.5mm
100n	4	MLCC	25v min	2.5mm
2n7	1	Film	25v min	5mm
10n	1	Film	25v min	5mm
47n	5	Film	25v min	5mm
100n	1	Film	25v min	5mm
220n	2	Film	25v min	5mm
1uF	1	Film	25v min	5mm
10uF BP	1	Bi-Polar / Non-Polar	25v min	
22uF	1	Low Profile	25v min	
4.3v	1	Zener Diode		
2n5952	4	matched JFETs		
20k	1	Bourns 3362p		
200k	1	Bourns 3362p		
OPA2134	1			
TLE2074	1			
LM358	1			
DPDT	1	On/Off/On		
DPDT	1	On/On/On		
1MC	1	included w/ board	16mm	
500kB	1	PCB Right Angle	16mm	
20kW	1	PCB Right Angle	16mm	
1kB	1	PCB Right Angle, Plastic Shaft	9mm	

This list is for the audio board only. See the appropriate Switching Board doc for the parts needed for the switching system.

- You can sub 1.4k or 1.5k for the 1.43k resistors.
- Requires 4 matched 2n5952 JFET transistors (or appropriate JFET substitute).
- 22k resistor array must be “bussed” style. 10k resistor array must be “isolated” style (see pg.4).
- Does not include switching board parts (this effect uses bi-polar power). See switching board doc for details.
- The included 1MC pot is custom-made with a 5% tolerance.

**1k43 1/8W resistor:**

<http://www.mouser.com/Search/ProductDetail.aspx?R=RN60C1431FB14virtualkey6130000virtualkey71-RN60C-F-1.43K>

**22pF (2.5mm, MLCC):**

<http://www.mouser.com/Search/ProductDetail.aspx?R=C315C220J5G5TAvirtualkey6460000virtualkey80-C315C220J5G>

**1n (2.5mm, MLCC):**

<http://www.mouser.com/Search/ProductDetail.aspx?R=C320C102J5G5TAvirtualkey6460000virtualkey80-C320C102J5G>

**100n (2.5mm, MLCC):**

<http://www.mouser.com/Search/ProductDetail.aspx?R=C320C104K5R5TAvirtualkey6460000virtualkey80-C320C104K5R>

**10uF BiPolar:**

<http://www.mouser.com/Search/ProductDetail.aspx?R=ECE-A1EN100Uvirtualkey66720000virtualkey667-ECE-A1EN100U>

**22uF (Low Profile):**

<http://www.mouser.com/ProductDetail/Nichicon/UMA1E220MDD/?qs=sGAEpiMZZMtZ1n0r9vR22aNb8fDq44Jyo3r1IrbDMag%3d>

**4.3v Zener:**

<http://www.mouser.com/Search/ProductDetail.aspx?R=1N4731ATRvirtualkey51210000virtualkey512-1N4731ATR>

**10k Resistor Array:**

<http://www.mouser.com/ProductDetail/Bourns/4308R-102-103LF/?qs=sGAEpiMZZMvrnc6UYKmaNUjQ8u6jS5WRGwLbdv9WWM%3d>

**22k Resistor Array:**

<http://www.mouser.com/Search/ProductDetail.aspx?R=4306R-101-223LFvirtualkey65210000virtualkey652-4306R-1LF-22K>

**20k (3362p):**

<http://www.mouser.com/ProductDetail/Bourns/3362P-1-203LF/?qs=sGAEpiMZZMvygUB3GLcD7iDNlz%2fNDK0mhkYgCqD12rc%3d>

**200k (3362p):**

<http://www.mouser.com/ProductDetail/Bourns/3362P-1-204LF/?qs=sGAEpiMZZMvygUB3GLcD7msVLjsDIwpw3TQu8QwHjhw%3d>

**DPDT (On/Off/On):**

<http://www.smallbear-electronics.mybigcommerce.com/dpdt-center-off-pc-mount/>

**DPDT (On/On/On):**

<http://www.smallbear-electronics.mybigcommerce.com/dpdt-on-on-on-pc-mount/>

**16mm Right Angle PC-Mount:**

<http://www.smallbear-electronics.mybigcommerce.com/alpha-single-gang-16mm-right-angle-pc-mount/>

**9mm Right Angle PC-Mount, Plastic Shaft:**

<http://www.smallbear-electronics.mybigcommerce.com/alpha-single-gang-9mm-right-angle-pc-mount-w-knurled-plastic-shaft/>

# Wiring

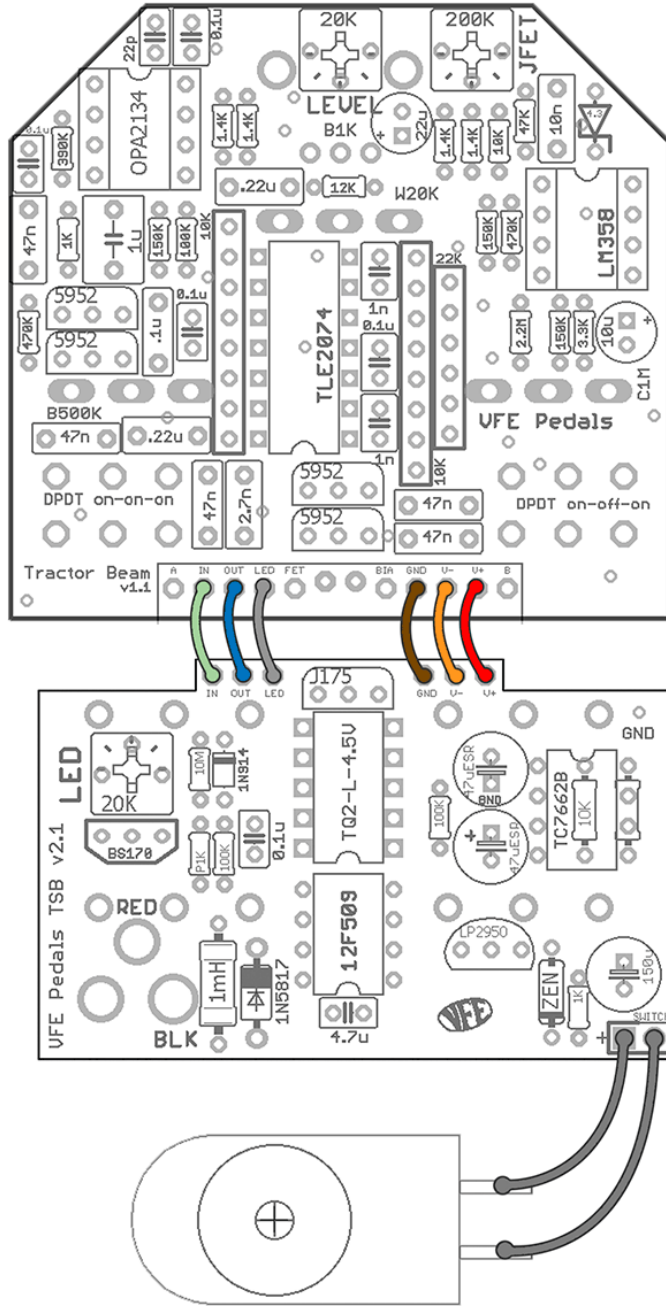

## Overview

**From the VFE Website:** "As I experimented with phaser circuits, I quickly realized that phasers can do much more than just the resonant sweep they are most commonly associated with (think EVH's "Eruption"). The design of the Tractor Beam was not just about the craziest, extreme phase sounds - it was much more about the far more useful subtle phase tones that can really make your riffs without dominating your tone.

In version 2 of the Tractor Beam, I experimented with the range and sweep of the SPEED, CENTER, and FEEDBACK controls. As crazy as it seemed at the time, I was able to add more range to the original design and still make it easier to dial in the precise setting you want."

---

## Controls

Descriptions from the VFE website: <http://vfepedals.com/tractor-beam.html>

**SPEED:** Sets the speed of the phaser. In version 2, we increased the max speed by 50% and doubled the rate of the slowest speed. In order to have a super-wide range that is still easy to dial in, we had pots custom-made specifically for the Tractor Beam.

**CENTER:** Sets the center of the phase sweep. Turn counterclockwise for low-end throb, turn clockwise for watery shimmer, and set at noon for a full-range sweep.

**FEEDBACK:** Sets the feedback, which is perfect for those slow, resonant phase sweeps. Clockwise = negative feedback, counterclockwise = positive feedback, 12:00 = zero feedback.

**MIX:** Blends between the dry, unaffected signal and the wet, phase-modulated signal. Because phasers get their sound by the interaction of the dry signal, the 12:00 position will yield the strongest phasing. Turn counterclockwise for a resonant tone with less pitch modulation. Turn clockwise for pitch modulation with less phase resonance.

**STAGES:** Selects the number of phase stages. More stages = wider phase sweep. The 3-stage position is inverted, for reverse phase sweeps.

**MODE:** Selects the voicing of the phaser. P = synced phase sweep, V = warbling vibe sweep, PV = half phase, half vibe voicing.

**INTERNAL CONTROLS:** The internal LEVEL trimpot sets the output volume. NOTE: The JFET is factory set for maximum phase sweep - DO NOT ADJUST. (obviously, we will be adjusting this)

---

## Notes

As shown on the pg.1 illustration, there is a cap soldered in parallel with the 4.3v Zener diode. This is to facilitate noise reduction. Peter recommends a value between 22uF – 100uF. I have linked a 22uF low-profile electrolytic on pg.4. This cap should be soldered directly to the diode, + side toward the diode band (cathode) and – side to the other (anode of the Zener diode).

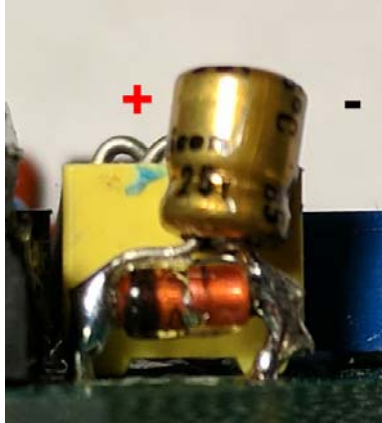

I recommend soldering the cap to the diode first then solder the diode to the PCB. You will get a better looking result than what I did here (soldered the cap after the fact).

---

This build uses three resistor networks. These help reduce part count in order to fit this circuit in such a small size. There is nothing special about these. Just make sure you order the ones linked on pg.4 or their equivalent. These networks do not have orientation so you can solder them in either way (*10.23 correction: the bussed 22k network does have an orientation but it doesn't matter on this PCB because each end is connected to ground so it gets bussed either way*). I soldered mine with the labeling facing left.

---

The Tractor Beam does require four matched 2n5952 transistors in order to work. If you want to match your own you'll need a good pile of them. Usually 50 -100 to get a perfect match. Or, you can buy pre-matched sets.

### **Matched Sets**

<https://www.musikding.de/2N5952-matched-quartett>

<https://store.generalguitargadgets.com/2n5952-set.html>

<http://www.guitarpcb.com/apps/webstore/products/show/1794746>

If you want to match your own, check out the info in the [NomNom](#) doc on how to do it. I have not tested the Tractor Beam with 2n5457 but I believe they will work (pinout is opposite the 2n5952). You can breadboard the circuit used to for matching in about 5 minutes.

BTW: Socketing these transistors is probably a good idea (I did on my build).

---

The Tractor Beam will need to be calibrated after population. Calibrating is very easy. Set all the pots to the 12:00 position, the Stages switch to "4" and the Mode switch to "P". Adjust the 200k "JFET" trimmer until you hear the phasing. The range may be narrow on the trimmer so you might have to make a couple micro-adjustments – try setting your Speed to slow and Feedback to high while making adjustments to ensure you are getting the best result over the most range.

---



## Voltages

Current Draw: 14mA off, 22mA on. 9.42vDC One Spot.

OPA2134	DC	LM358	DC	TLE2074	DC	2n5952 (all)	DC
1	4.5mV	1	varies	1	4mV	D	4mV
2	4.5mV	2	varies	2	3.8mV	G	vaires
3	3.6mV	3	varies	3	4mV	S	4mV
4	-7.36v	4	-7.36v	4	8.05v		
5	3.3mV	5	varies	5	4.2mV		
6	3.2mV	6	varies	6	4.2mV		
7	2.9mV	7	varies	7	3.3mV		
8	8.05v	8	8.05v	8	4.2mV		
				9	4.1mV		
				10	4.5mV		
				11	-7.36v		
				12	4.3mV		
				13	4.1mV		
				14	4.2mV		

The mV readings can be interpreted as 0vDC which is virtual ground in this effect.



Tractor Beam  
<http://www.vfepedals.com/>

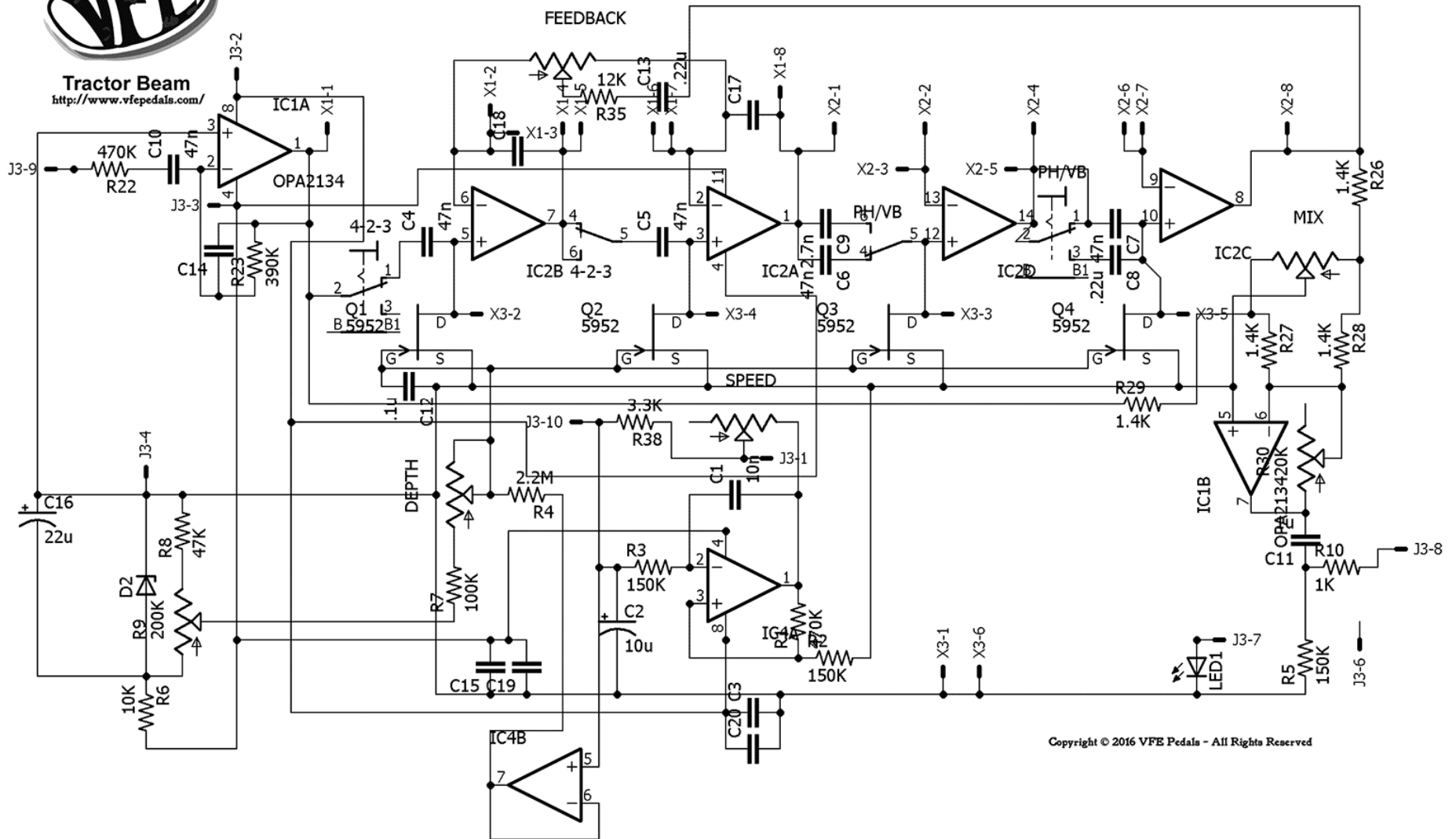

Attempts to re-draw or pull apart this schem in Eagle proved rather unsuccessful. Rather than post something that might contain errors, this is the actual schematic used to design the PCB.